

TECHNICAL SHEETS FOR COORDINATION

VERTICAL RECOMMENDATION FOR USE SHEETS (RfUs) Status in September 2024

Number CNB/M/ (1)	Revision (Rev)	Key words	Approved by Vertical Group of NBs ⁽²⁾ on:	Approved by Horizontal Committee of NBs ⁽²⁾ on:	Endorsed by Machinery Expert Group/MWG on:
Vertical Group 01 – Woodworking machinery					
01.029	05	Tractor driven machine, P.T.O.	24/04/2009	09/12/1998	03/03/2000
01.087	08	Chain saws for tree service/top handle machine, battery-powered	02/05/2023	31/05/2024	12/04/2024
01.089	03	Electric and electronic brakes, run-down time, failure of power supply	21/05/2014	18/06/2014	08/01/2015
01.092	02	Single blade edging circular rip sawing machines with power driven saw unit and manual loading and/or unloading	31/03/2021	16/12/2021	23/03/2023
01.093	02	Pruner saws, chain saws, battery-powered	02/05/2023	31/05/2023	12/04/2023
Vertical Group 02 – Meatworking machinery					
02.001	02	Adjustable guards	17/11/2011	13/12/2011	23/04/2012
Vertical Group 03 – Presses for the cold working of metals					
03.002	15	Presses – Metal – Field of application	30/09/2009	12/12/1995	04/06/1996
03.004	06	Technical file	30/09/2009	12/12/1995	04/06/1996
03.005	03	Platform, ladders	30/09/2009	17/04/1996	08/06/1998
03.013	08	Acceptability of components of type examined presses	13/10/2010	14/12/2010	23/05/2011
03.022	06	Intrinsic safe pneumatic valve	30/09/2009	18/09/1997	08/06/1998
03.027	09	Secondary protection / Two Hands Control Device / Active Optoelectronic Protective Devices	19/09/2019	14/06/2022	23/03/2023
03.028	06	Failing of springs in the brake	30/09/2009	18/09/1997	08/06/1998
03.029	04	Reaching over, under and around the detection zone	30/09/2009	12/12/1995	04/06/1996
03.032	07	Fixing the tools, failure of one component	24/05/2022	14/06/2022	23/03/2023
03.035	07	Crushing hazards, ram frame	24/05/2022	14/06/2022	23/03/2023
03.102	06	Overrun detection / Screw presses	30/09/2009	09/06/2005	29/10/2005
03.111	09	Stopping time measurement / die cushion / ejector	12/09/2019	14/06/2022	23/03/2023
03.124	07	Press-brakes / tandem assembly	29/09/2009	21/11/2005	20/04/2006
03.128	08	Overlapping, Monitoring Valves	29/09/2009	09/06/2005	29/10/2005
03.141	04	Bypassing monitored restraint valves	29/09/2009	02/06/1999	03/03/2000
03.154	07	Hydraulic presses, Mechanical restraint device, Production and Maintenance	30/09/2009	24/10/2002	02/03/2004
03.164	06	Press Brakes – Mode selection	29/09/2009	16/06/2003	17/12/2003
03.166	06	Press Brakes, AOPD	29/09/2009	16/06/2003	17/12/2003
03.172	04	Safety valve, separated clutch and brake	29/09/2009	16/06/2003	17/12/2003

Number CNB/M/ (1)	Revision (Rev)	Key words	Approved by Vertical Group of NBs⁽²⁾ on:	Approved by Horizontal Committee of NBs⁽²⁾ on:	Endorsed by Machinery Expert Group/MWG on:
03.176	05	Restart / Reset / AOPD	29/09/2009	09/06/2005	29/10/2005
03.180	04	Press-brakes – Ancillary devices – Powered tools clamping devices	28/09/2009	09/12/2004	24/05/2005
03.182	04	Press-brakes – ESPE using AOPD in the form of laser beams – Additional crushing hazard	28/09/2009	09/12/2004	24/05/2005
03.185	05	Movable screens	30/09/2009	09/06/2005	29/10/2005
03.186	06	Acceptability of a component, configurable or parameterizable PES	28/09/2009	26/11/2009	26/05/2010
03.187	05	Failure of auxiliary powered functions for setting	30/09/2009	09/06/2005	29/10/2005
03.188	06	Front guard switch	28/09/2009	10/08/2008	08/01/2009
03.189	05	Defeat of protective measures on presses	30/09/2009	21/11/2005	20/04/2006
03.192	04	Press brakes – secondary working devices	06/10/2008	09/12/2008	18/06/2009
03.193	06	Servo Press (Power Presses & Press Brakes), Muting, Slow Speed / Directional Monitoring	03/03/2009	10/06/2009	31/01/2018
03.194	05	Servo press (Power Presses & Press Brakes), brake	03/03/2009	10/06/2009	25/12/2009
03.196	04	Servo presses, protective measures	07/10/2008	09/12/2008	18/06/2009
03.200	05	Servo-presses (Power Presses & Press Brakes), Stopping performance monitoring	03/03/2009	10/06/2009	25/12/2009
03.201	05	Servo-presses (Power Presses & Press Brakes), STO, prevention of unintended start	04/03/2009	10/06/2009	25/12/2009
03.202	04	Press brakes – back gauge movement initiation	03/03/2009	10/06/2009	25/12/2009
03.204	03	Presses – Safety distances	28/09/2011	11/12/2012	04/06/2013
03.206	03	Presses – Two hand control device (THCD)	27/09/2012	11/12/2012	04/06/2013
03.207	03	Press-brakes – Powered work-piece supports	27/09/2012	11/12/2012	04/06/2013
03.209	03	Hydraulically actuated clamps	26/09/2013	10/12/2013	31/01/2018
03.210	04	Servo press-brake connection between motor and screw	24/09/2015	02/12/2015	23/09/2016
03.211	02	Press-brakes – Powered work-piece supports	26/09/2014	24/06/2015	23/09/2016
03.214	04	Press brake / Control panel / Wireless	12/09/2019	14/06/2022	23/03/2023
03.216	04	Presses with a servo drive system (mechanical servo presses); brakes	24/05/2022	14/06/2022	23/03/2023
03.217	02	Reset function	12/09/2019	14/06/2022	23/03/2023
Vertical Group 04 – Injection or compression moulding machines					
04.009	12	Moulding machinery / automatic loading and unloading	03/05/2023	31/05/2023	12/04/2024
04.014	08	Machine with fence and robot; crossing the mould area into the fence area behind the machine	04/05/2023	31/05/2023	12/04/2024
04.029	08	Injection or Compression Moulding Machine Response	04/05/2023	31/05/2023	12/04/2024

Number CNB/M/ (1)	Revision (Rev)	Key words	Approved by Vertical Group of NBs⁽²⁾ on:	Approved by Horizontal Committee of NBs⁽²⁾ on:	Endorsed by Machinery Expert Group/MWG on:
		time			
04.040	09	Automatic sequence control, guard closing, latch retracting, mould closing	26/06/2019	07/02/2020	20/05/2020
04.053	07	24 VDC hydraulic valves, protective bonding circuit connection on the voltage supply plug of a 24 VDC solenoid valve	09/06/2021	16/12/2021	23/03/2023
04.076	06	Plastics and rubber hydraulic IMM – horizontal mould closing movement – motor control unit	09/06/2021	16/12/2021	23/03/2023
04.083	07	Injection machines with tie bar distances >1200 mm; person standing behind the mould at the rear side of the machine or entering the mould area from the operator's side	03/05/2022	14/06/2022	23/03/2023
04.085	07	Mould opening for machines with horizontal closing movement and electrical axis	03/05/2022	14/06/2022	23/03/2023
04.086	07	Electrical axis; guards locking, detection standstill	03/05/2022	14/06/2022	23/03/2023
04.087	06	Plug and socket combinations for subunits on injection moulding machines	03/05/2022	14/06/2022	23/03/2023
Vertical Group 05 – Machines for underground work					
05.001	05	Internal combustion engine, emission of dust, gas, exhaust	03/11/2009	07/12/2000	04/01/2005
05.002	05	Internal combustion engine, emission of dust, gas, exhaust, methane in intake air	03/11/2009	07/12/2000	04/01/2005
05.007	04	Internal combustion engine, emission of dust, gas, exhaust, limits	03/11/2009	07/12/2000	04/01/2005
05.201	03	Hydraulic powered roof support	03/11/2009	13/12/1995	04/06/1996
05.202	02	Hydraulic powered roof support, components with safety function, safety components	03/11/2009	13/12/1995	04/06/1996
05.208	03	Hydraulic powered roof support, placing on the market, putting into service	03/11/2009	12/12/1995	04/06/1996
05.220	05	Hydraulic powered roof support, support unit, technical file, EC-type examination	03/11/2009	07/12/2000	04/01/2005
05.221	04	Hydraulic powered roof support, single props	03/11/2009	07/12/2000	04/01/2005
05.222	04	Hydraulic powered roof support, pressure supply, EC-type examination	03/11/2009	07/12/2000	04/01/2005
05.601	05	Locomotive, EC-type examination, running test	03/11/2009	07/12/2000	04/01/2005
05.603	05	Locomotive, EC type examination certificate, putting into operation, control	03/11/2009	07/12/2000	04/01/2005
05.604	05	Locomotive, definition	03/11/2009	07/12/2000	04/01/2005
05.801	02	Machines for tunnels	03/11/2009	12/12/1995	25/03/1997

Number CNB/M/ (1)	Revision (Rev)	Key words	Approved by Vertical Group of NBs ⁽²⁾ on:	Approved by Horizontal Committee of NBs ⁽²⁾ on:	Endorsed by Machinery Expert Group/MWG on:
Vertical Group 06 – Refuse collection vehicles					
06.005	05	Calculations	15/04/2010	11/03/1997	08/06/1998
06.012	06	Automatic lifting device-operation mode	15/04/2010	10/06/2008	08/01/2009
06.016	09	Refuse collection vehicle (RCV) - energy separation main switch	22/06/2022	18/12/2023	12/04/2024
06.023	08	Refuse Collection Vehicles (RCV) – Hose burst protection valves	15/04/2015	24/06/2015	23/09/2016
06.025	03	Electrical equipment	15/04/2010	10/06/2008	08/01/2009
06.026	07	Automatic gear box	15/04/2010	10/06/2008	08/01/2009
06.027	07	RCV – fixing points of the bodywork on the chassis	15/04/2010	15/06/2010	30/12/2010
06.034	10	Refuse collection vehicle (RCV) - rear footboard	15/04/2015	24/06/2015	23/09/2016
06.043	03	Safety distances / Shape of the guard	26/06/2019	07/02/2020	20/05/2020
06.047	02	Danger zone / Visibility / testing	02/06/2021	16/12/2021	23/03/2023
06.050	02	Rolling backward / detection / footboard not in unusable position	12/05/2023	31/05/2023	12/04/2024
Vertical Group 08 – Vehicle servicing lifts					
08.001	04	Polyamide Nuts	12/04/2010	13/12/1995	04/06/1996
08.002	04	EC type test	12/04/2010	09/12/1998	03/03/2000
08.003	05	Instruction handbook, check	12/04/2010	09/12/1998	03/03/2000
08.008	03	Auxiliary lifting systems	12/04/2010	17/04/1996	08/06/1998
08.015	03	Rails foot protectors, protection against pinching points	12/04/2010	11/12/2003	01/07/2004
08.016	03	Chassis supporting vehicle lift for road vehicles, load distribution	12/04/2010	11/12/2003	01/07/2004
08.018	05	Load distribution on two post lifts with load-bearing arms	25/04/2013	26/06/2013	22/11/2013
08.023	03	Maximum inclination of pickup plates and pads	08/06/2021	16/12/2021	23/03/2023
08.024	04	Welding examination	21/12/2021	14/06/2022	23/03/2023
08.025	03	Structural Calculations	31/05/2022	14/06/2022	23/03/2023
Vertical Group 09 – Lifting Persons Device (LPD)					
09.206	04	Lifting Persons Device (LPD), Suspended Access Equipment, modular construction, certification	13/04/2010	11/12/2003	14/03/2007
09.207	10	Type-examination	13/04/2010	26/11/2009	26/05/2010
09.209	04	EC type-examination, work platform, loader crane	13/04/2010	11/12/2003	01/07/2004
09.305	06	Mobile Elevated Workplatform (MEWP), levelling system	13/04/2010	11/06/1998	09/04/2001
09.306	05	Mobile Elevated Workplatform (MEWP), levelling system	13/04/2010	11/06/1998	09/04/2001
09.307	04	Lifting Persons Device, safety gear	13/04/2010	24/05/2000	09/04/2001
09.309	04	Mobile Elevated Work Platform, MEWP, access, movable guard, abnormal use	13/04/2010	24/05/2000	09/04/2001
09.310	05	Man rider winches, one rope suspension	13/04/2010	24/05/2000	09/04/2001

Number CNB/M/ (1)	Revision (Rev)	Key words	Approved by Vertical Group of NBs⁽²⁾ on:	Approved by Horizontal Committee of NBs⁽²⁾ on:	Endorsed by Machinery Expert Group/MWG on:
09.318	07	Crushing hazards, ram frame	12/06/2015	29/06/2016	23/03/2023
09.401	08	MEWP, control devices, emergency stop, override	13/04/2010	11/12/2003	01/07/2004
09.501	05	Radiation, EC type- examination, EMC directive	13/04/2010	24/05/2000	09/04/2001
09.502	02	Lifting platforms, lifts, gripping device/safety gear, tripping device / overspeed governor, safety device, lifting persons	01/06/2015	29/06/2016	23/03/2023

Vertical Group 11 – Safety components

11.017	05	EC type-examination, pre-standards	25/10/2010	11/06/1998	09/04/2001
11.027	08	Two-hand control devices, synchronous actuation	25/10/2010	14/12/2010	23/05/2011
11.031	09	ESPE Type 2 with PLC as means of periodic test	25/10/2010	14/12/2010	23/05/2011
11.032	05	Arrangement of visual indicators	25/10/2010	03/03/2004	24/12/2004
11.033	09	-	22/05/2019	16/12/2021	23/03/2023
11.035	08	Indication of a muted ESPE, colour of the mute indicator(s) of an ESPE	25/10/2010	14/12/2010	23/05/2011
11.036	07	Laser scanner, industrial truck	25/10/2010	14/12/2010	23/05/2011
11.042	04	THCD, non-mechanical actuating devices	25/10/2010	21/11/2005	20/04/2006
11.047	03	Using parts with wear-out in safety components	11/05/2010	15/06/2010	30/12/2010
11.049	03	Logic units to ensure safety functions / Environmental conditions	25/10/2010	14/12/2010	23/05/2011
11.050	05	Failure, electromechanical outputs	06/06/2013	26/06/2013	22/11/2013
11.052	02	Safety components, safety functions	18/10/2011	13/12/2011	23/04/2012
11.053	03	Manual reset function	10/05/2012	28/06/2012	17/01/2013
11.055	04	Cogeneration plants, combined heat and power plants (CHP), grid monitoring	02/06/2014	17/06/2014	08/01/2015
11.056	03	Two-hand control devices, synchronous actuation, operating conditions	07/06/2013	26/06/2013	22/11/2013
11.058	03	Safety component, warning device	07/06/2013	26/06/2013	22/11/2013
11.059	03	Diagnostic functions, EN 61508:2010	03/06/2014	17/06/2014	08/01/2015
11.060	06	External DC power supply of safety component, PELV, abnormal voltage	22/05/2019	16/12/2021	23/03/2023
11.061	06	RFID-based protective devices	02/06/2015	29/06/2016	31/01/2018
11.062	04	Pressure-sensitive protective device, sensor, control unit, OSSDs, definition	09/06/2015	02/12/2015	23/09/2016
11.063	02	EC type-examination, laboratory	02/06/2016	31/05/2023	12/04/2024
11.065	03	AOPD, type	01/06/2017	07/06/2017	31/01/2018
11.067	03	Testing, witness testing, remote testing of safety components and logic unit	22/01/2021	16/12/2021	23/03/2023
11.068	02	AOPDDR, IP protection class	22/01/2021	16/12/2021	23/03/2023

Number CNB/M/ (1)	Revision (Rev)	Key words	Approved by Vertical Group of NBs⁽²⁾ on:	Approved by Horizontal Committee of NBs⁽²⁾ on:	Endorsed by Machinery Expert Group/MWG on:
11.069	02	Transformers	14/09/2021	16/12/2021	23/03/2023
11.071	02	Lack of Clarity for EMC Immunity Testing for Safety Components and integral Safety Functions	04/05/2023	31/05/2023	12/04/2024
Vertical Group 12 – ROPS and FOPS					
12.007	05	DLV	21/11/2013	10/12/2013	15/04/2014
12.009	05	Minor modification	21/11/2013	10/12/2013	15/04/2014
12.010	05	FOPS, Standing operator	21/11/2013	10/12/2013	15/04/2014
12.012	07	ROPS	21/11/2013	10/12/2013	15/04/2014
12.015	05	ROPS, FOPS, repair, substitution	21/11/2013	10/12/2013	31/01/2018
12.016	02	FOPS, tiltable cab	21/11/2013	10/12/2013	15/04/2014
Vertical Group 13 – Full quality assurance					
13.000	03	Equivalence to Annex IX	21/08/2008	09/12/2008	18/06/2009
13.001	04	Final inspection, quality management, intermediate inspections	17/09/2007	10/06/2008	08/01/2009
13.002	07	quality system, compliance with standards, accreditation	26/08/2010	14/12/2010	23/05/2011
13.003	04	Application, quotation, selection of Notified Body	17/09/2007	10/06/2008	08/01/2009
13.004	04	Manufacturer, sub-contractors, conformity, supplier, subsidiaries	17/09/2007	10/06/2008	08/01/2009
13.005	04	Representative model, categories of machinery, risks	17/09/2007	10/06/2008	08/01/2009
13.006	02	EC declaration of conformity, technical file	17/09/2007	04/12/2007	04/06/2008
13.007	03	Technical file, assessment on site, quality system	17/09/2007	04/12/2007	04/06/2008
13.008	02	Complete technical file, documentation, complex machinery, audit	17/09/2007	04/12/2007	04/06/2008
13.009	04	Quality system documentation, quality management manual, certificates, audit reports, language	17/09/2007	10/06/2008	08/01/2009
13.010	04	Technical design specification, sample, manufacturing facilities, inspections, audit plan	17/09/2007	10/06/2008	08/01/2009
13.011	04	Harmonized standards, responsibility, design review	17/09/2007	10/06/2008	08/01/2009
13.012	05	Design inspection, design verification, independence, level of confidence	23/10/2012	10/06/2008	08/01/2009
13.013	03	Product complexity, validation, competence	17/09/2007	04/12/2007	04/06/2008
13.014	04	Competency qualification of personnel, product specific requirements	17/09/2007	10/06/2008	08/01/2009
13.015	04	Machinery design, quality, compliance	17/09/2007	10/06/2008	08/01/2009
13.016	05	Existing certification, conformance, certified quality system	23/10/2012	10/06/2008	08/01/2009
13.017	02	Auditors, experts, competence	17/09/2007	04/12/2007	04/06/2008

Number CNB/M/⁽¹⁾	Revision (Rev)	Key words	Approved by Vertical Group of NBs⁽²⁾ on:	Approved by Horizontal Committee of NBs⁽²⁾ on:	Endorsed by Machinery Expert Group/MWG on:
13.018	02	EHSR, technical file, review	17/09/2007	04/12/2007	04/06/2008
13.019	04	Product changes, changes of quality system, significant changes, contract	17/09/2007	10/06/2008	08/01/2009
13.020	04	Notification, report, certificate	17/09/2007	10/06/2008	08/01/2009
13.021	04	Audit frequency and duration, surveillance audits	17/09/2007	10/06/2008	08/01/2009
13.022	02	Unannounced visits, contracts	17/09/2007	04/12/2007	04/06/2008
13.023	04	Obligation to preserve	12/05/2009	10/06/2009	25/12/2009
13.024	04	Obligation to preserve, quality assurance system documentation	17/09/2007	10/06/2008	08/01/2009
13.025	04	Last date of manufacture	17/09/2007	10/06/2008	08/01/2009
13.026	02	audit frequency and duration, assessment	17/09/2007	04/12/2007	04/06/2008
13.028	03	technical file, sample, manufacturing facilities, inspections, audit plan	17/09/2007	10/06/2008	08/01/2009
13.029	03	Subcontract	21/08/2008	09/12/2008	18/06/2009
13.030	03	Reassessment	21/08/2008	09/12/2008	18/06/2009
13.031	04	Annex X	12/05/2009	10/06/2009	25/12/2009
13.033	04	Quality system, audit plan	23/10/2012	09/12/2008	18/06/2009
13.034	04	Certificate	12/05/2009	10/06/2009	25/12/2009
13.035	04	Annex X	12/05/2009	10/06/2009	25/12/2009
13.037	03	Surveillance, quality system, technical file	12/05/2009	10/06/2009	25/12/2009
Vertical Group 14 – Portable cartridge-operated fixing and other impact machinery					
14.001	03	Bolt setting devices, Cattle stunners, other hand held cartridge operated fixing and impact machinery	11/12/2013	18/06/2014	08/01/2015

(1): CNB/M/xx.xxx RERev yy = Coordination of Notified Bodies/Machinery/Numbering of the RfUs
R: Recommendation for Use E: English version Rev: Revision yy: index of the Revision

(2): NBs = Notified Bodies

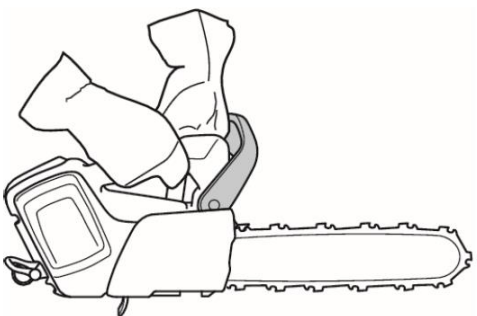
	CO-ORDINATION OF NOTIFIED BODIES Machinery Directive 2006/42/EC + amendments RECOMMENDATION FOR USE		CNB/M/01.087 Revision: 08 Language: EN
Number of pages: 1 Origin: VG1 - Woodworking machinery	Date: 31.07.2023	To be approved by: <input checked="" type="checkbox"/> Vertical Group <input checked="" type="checkbox"/> Horizontal Committee To be endorsed by: <input checked="" type="checkbox"/> Machinery Expert Group	Approved on: 02.05.2023 31.05.2023 Endorsed on: 12.04.2024
Question related to: Directive 2006/42/EC Annex: IV	Article: - EHSR (1): -	EN/prEN: EN ISO 11681-2 EN 62841-1, EN 62841-4-1 Normative clause: - CEN TC concerned: CENELEC TC 116	Other: - Other clause: -
Key words: Chain saws for tree service/top handle machine, battery-powered			
<p>There is no harmonized C-type standard available for those machines. Type testing on the basis of EN 62841-1 and EN 62841-4-1 would not satisfy the safety requirements for battery-powered chain saws for tree service. EN ISO 11681-2 is restricted to gasoline engines.</p> <p>Question: What standard(s) can alternatively be used for type testing of battery-powered chain saws for tree service?</p>			
<p>Solution:</p> <p>Battery-powered chain saws for tree service with a maximum weight *) of 4.3 kg including the battery recommended to be used with these machines can be type tested according to the relevant paragraphs of:</p> <p style="padding-left: 40px;">EN 62841-1 in conjunction with EN 62841-4-1 for the electrical requirements and EN ISO 11681-2 for non-electrical requirements.</p> <p>*) empty oil tank and without guide bar and saw chain as defined in EN ISO 11681-2</p> <p>Note: <i>This RfU only covers battery powered chain saws for tree service (a.k.a. top handle machines) - because of the (additional) hazards from power supply cables during tree service are out of scope. Pruner saws are out of scope of this RfU.</i></p> <p>Typical design of chain saw covered by this RfU:</p> 			

(1) Essential health and safety requirement

Note: According to point 6.6 of the Guide of the implementation of directives based on the New Approach and the Global Approach, the notified bodies apply as general guidance this recommendation for use.

	CO-ORDINATION OF NOTIFIED BODIES Machinery Directive 2006/42/EC as amended RECOMMENDATION FOR USE		CNB/M/01.089 Revision 03 Language : EN
Number of pages : 1	Date : 21/05/2014	To be approved by :	Approved on :
Origin : VG1 Woodworking machinery		<input checked="" type="checkbox"/> Vertical Group..... <input checked="" type="checkbox"/> Horizontal Committee..... To be endorsed by: <input checked="" type="checkbox"/> Machinery Working Group.....	21/05/2014 18/06/2014 Endorsed on : 08/01/2015
Question related to : 2006/42/EC	Article :	Other : -	
Annex : IV	ESR (1): 1.2.6	Normative clause : - CEN TC concerned : TC 142, CENELEC TC 116	Other clause : -
Key words : Electric and electronic brakes, run-down time, failure of power supply			
<p>Clause 1.2.6 of the machinery directive 2006/42/EC states: The interruption, the re-establishment after an interruption or the fluctuation in whatever manner of the power supply to the machinery must not lead to dangerous situations.</p> <p>More and more machines for wood working have electric or electronic brakes for the tool drive motor. Most of these brakes do not work without power supply. When there is a failure in the power supply during normal operation, the tool spindle is non-braked and the run-down time may be much higher than the acceptable run-down time outlined in the specific machine standard (mostly 10 s). E. g. on single spindle molding machines non-braked run-down times of several minutes may be possible with large and heavy tools.</p> <p>Note: <i>The same situation occurs, if the stop is performed in stop category 0 due to a failure in the logic of an electronic brake.</i></p> <p>Question:</p> <p>a) Is the situation as described above acceptable or is a fall-back solution for power supply failures, e. g. mechanical brake or braking by UPS or energy recuperation necessary to achieve the required run-down time?</p>			
<p>Solution :</p> <p>Note: <i>No further regulation is necessary, if tool access is prevented by fixed or moveable interlocked guards with guard locking (as far as locking needs power supply to be opened). On the other hand there are many Annex IV woodworking machines having only adjustable guards in some sections of the non-cutting part and no guarding at all for the cutting part of the tool. Only for these machines with unguarded access to the tool and which usually require a braked run-down time of not more than 10 seconds, the following applies.</i></p> <p>The risk assessment by CEN/TC 142/WG 1 and CENELEC/TC 116 lead to the conclusions that</p> <ul style="list-style-type: none"> - the probability of an accident due to uncontrolled run-down of tools after a failure in the energy supply of the machine is extremely low (low probability of uncontrolled run-down and low probability of deliberate access to tools at the same time) - the possible damage is high - the resulting risk is very low and thus acceptable. <p>The situation is <u>acceptable</u> since power supply failure is a seldom and specific situation that can be managed by the operator. He/she is aware of the dangerous situation and will handle any further manipulation on the machine with care.</p> <p>In order to reduce the risk, one or more warning labels in close proximity to the danger zone(s) stating that tool brake(s) may not operate effectively in the case of power supply failure should be required.</p> <p>Note: <i>A failure in the brake device logic is even more seldom. The standards in TC 142 require a stop category 0 (without braking) in this situation. Any further regulation for this situation is not reasonable.</i></p>			

(1) Essential safety regulations

Note: According to point 6.6 of the Guide of the implementation of directives based on the New Approach and the Global Approach, the notified bodies apply as general guidance this recommendation for use.

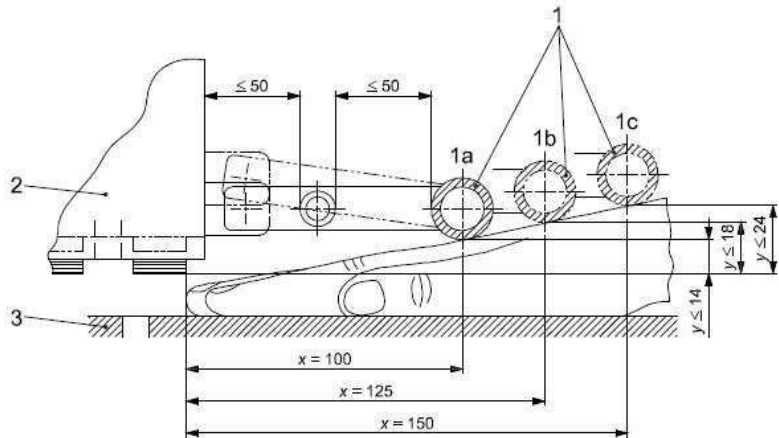
	CO-ORDINATION OF NOTIFIED BODIES Machinery Directive 2006/42/EC + amendments RECOMMENDATION FOR USE		CNB/M/01.092 Revision 02 Language: EN
Number of pages: 2	Date: 03.07.2023	To be approved by:	Approved on:
Origin: VG1 Woodworking Machinery		<input checked="" type="checkbox"/> Vertical Group 1 <input checked="" type="checkbox"/> Horizontal Committee To be endorsed by: <input checked="" type="checkbox"/> Machinery Expert Group	31.03.2021 16.12.2021 Endorsed on: 23.03.2023
Question related to: Directive 2006/42/EC	Article: 1.3.8	EN/prEN: EN 1870-8:2012	Other: -
Annex: IV	EHSR (1): -	Normative clause: 5.3.8	Other clauses: -
CEN TC concerned: CEN/TC 142 (ISO/TC 39)			
Key words: Single blade edging circular rip sawing machines with power driven saw unit and manual loading and/or unloading			
<p>Current situation:</p> <p>EN 1870-8: 2012 defines in clause 5.3.8, paragraph 1 and 2, the following requirement for a trip bar:</p> <p>Where powered workpiece clamping is provided by a pressure beam, the pressure beam shall meet the following requirements:</p> <p>a) it shall be positioned between the sectional safety curtains;</p> <p>b) it shall only operate when the sectional safety curtain is in its lowest position;</p> <p>c) it shall operate a maximum of 1 s after the sectional safety curtain has reached its lowest position.</p> <p>Where the machine is equipped with a work piece clamping device, a trip bar shall be provided on the operator's side of the pressure beam, and at the rear side of the pressure beam if operator access is not prevented.</p> <p style="text-align: right;">Dimensions in millimetres</p>  <p>Key</p> <p>1 trip bar 2 pressure beam 3 sectional safety curtain</p> <p style="text-align: center;">Figure 1 - Trip bar dimension</p> <p>Woodworking machines according to EN 1870-8 are for cutting solid wood. With lengths of 6 m this leads to considerable height differences (workpieces can be concave, convex, twisted). This can cause this trip bar to respond before the safety curtain has been completely lowered. For this reason, this protective device is sometimes unsuitable for specific applications.</p> <p>Question:</p> <p>Are there alternative ways to safeguard the clamping devices on these machines?</p>			

Solution:

An alternative way of safeguarding the clamping device works as follows:

1. The pressure beam shall be positioned between the sectional safety curtains.
2. The pressure beam shall touch the workpiece or the table not less than 2 s after the safety curtain's lower edge.
3. The pressure beam shall reach the clamping pressure before the sawing cycle is started.
4. The machine movement shall be controlled by a 3-position-switch (e.g. position switch acc. IEC 60947-5-8, foot pedal / *foot beam acc. IEC 60947-5-1) with the following characteristics:
 - Upper position: Stops the sawing cycle and releases clamping (all units return to the rest position).
 - Middle position: Starts and controls the sawing cycle.
 - Lower position: Stops the sawing cycle and releases clamping (all units return to the rest position).
 - The force to trigger a foot pedal / foot beam to the lowest position shall be between 100N and 200N.
 - The safety functions to start and stop the sawing cycle and to return the units in a safe position shall achieve PLr = c.
 - The clamping pressure monitoring shall achieve PLr = b.

*foot beams shall meet the requirements for foot pedals, they shall only differ in width.

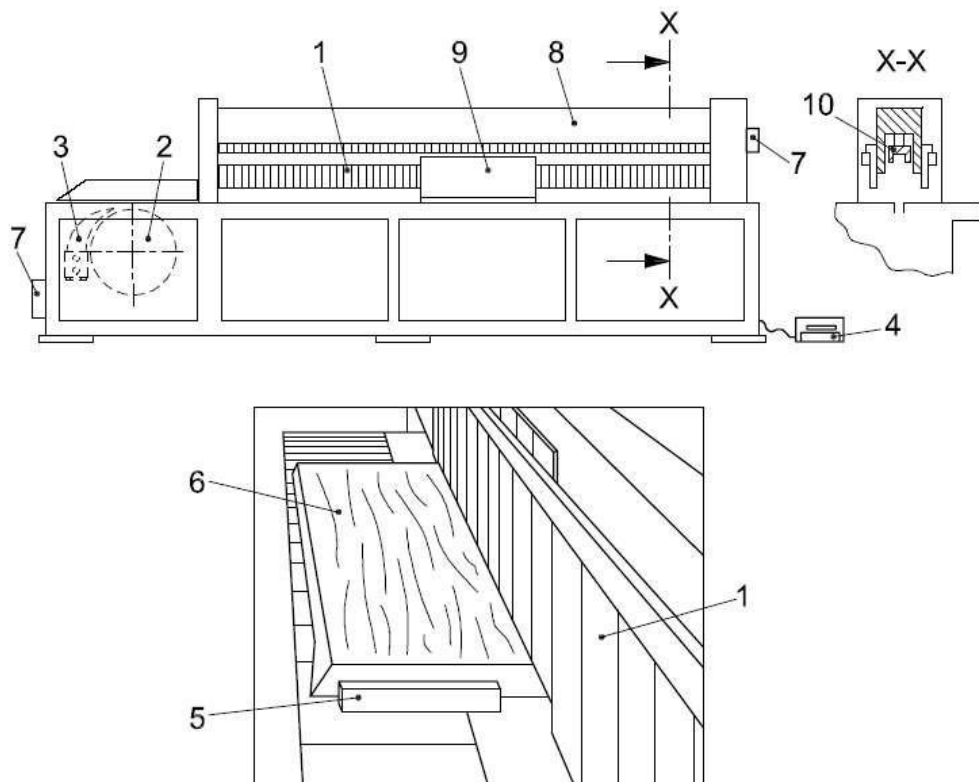

Key

- | | |
|----|--|
| 1 | sectional safety curtain |
| 2 | saw blade in rest position |
| 3 | riving knife |
| 4 | foot-pedal |
| 5 | workpiece end stop |
| 6 | workpiece |
| 7 | extraction outlet |
| 8 | sectional safety curtain support |
| 9 | front deterring/impeding device (on machines with raising and lowering of the saw unit at alternative positions) |
| 10 | workpiece clamping device (pressure beam) (optional) |

(1) Essential safety requirement

Note: According to point 6.6 of the Guide of the implementation of directives based on the New Approach and the Global Approach, the notified bodies apply as general guidance this recommendation for use.

	CO-ORDINATION OF NOTIFIED BODIES Machinery Directive 2006/42/EC + amendments RECOMMENDATION FOR USE		CNB/M/01.093 Revision: 02 Language: EN
Number of pages: 18	Date: 31.07.2023	To be approved by:	Approved on:
Origin: VG 1 Woodworking machinery		<input checked="" type="checkbox"/> Vertical Group <input checked="" type="checkbox"/> Horizontal Committee To be endorsed by: <input checked="" type="checkbox"/> Machinery Expert Group	02.05.2023 31.05.2023 Endorsed on: 12.04.2024
Question related to: Directive 2006/42/EC	Article: (general)	EN/prEN: -	Other: -
Annex: IV	EHSR (1): -	Normative clause: -	Other clause: -
Key words: Pruner saws, chain saws, battery-powered			
<p>Current situation:</p> <p>Battery-powered pruner saws as shown in the exemplary illustration have been available in the EU market with increasing variety. Due to their construction, and if using saw chains according to ISO 6531:2017, these machines are deemed to be portable chainsaws for woodworking as per item 8 in Annex IV of EU directive 2006/42/EC. However, none of the currently available (harmonized) C-type EN standards (EN 62841-4-1:2020 or EN ISO 11681-2:2011/A1:2017 or EN ISO 11681-2:2022) cover the particular EHSR of that kind of product. The risk assessment of any given pruner saw may result in varying results with respect to the requirements applied to achieve a presumption of conformity.</p> <p>Question:</p> <p>As long as no harmonized C-type EN standard is available for this kind of machinery, how can evaluation during EC Type-examination procedure be coordinated such that a potential divergence of evaluation results between Notified Bodies can be reduced?</p>			
<p>Solution:</p> <p>A specification for the technical evaluation of hand-held battery-operated pruner saws is provided below.</p>			



(1) Essential health and safety requirement

Note: According to point 6.6 of the Guide of the implementation of directives based on the New Approach and the Global Approach, the notified bodies apply as general guidance this recommendation for use.

Specification for the technical evaluation „Hand-held battery-operated pruner saws - Safety”

Foreword:

This document has been prepared by an Ad-Hoc Working group of VG1 Notified bodies.

Scope:

This test specification gives safety requirements and measures for their verification for the design and construction for hand-held battery-operated pruner saws with the following features:

- max. mass of 5,0 kg with the heaviest battery as described in the instruction manual installed but without a guide bar or saw chain fitted and with the lubrication tank, if any, empty;
- max. cutting length (EN 62841-4-1, 3.105): 200 mm;
- max. guide bar nose radius: 25 mm
- max. speed of the saw chain 8 m/s;
- intended to cut branches of trees or bushes by means of a saw-chain according to ISO 6531:2017, 3.3.1.;
- intended to be used with both hands on the machine and
- by persons having read and understood the safety requirements provided in the instruction handbook.

The requirements of this document specify a recognized level of risk mitigation with respect to the design of pruner saws and the instructions to be supplied.

This test specification also covers requirements for pruner saws that can be fitted with an extension pole. There is no limitation to the mass of extension poles as such.

This test specification is not applicable for electrically operated chain saws according to EN 62841-4-1 and electrically operated pole-mounted powered pruners according to EN ISO 11680-1.

Examples:



Referenced standards:

EN 62841-1:2015 + AC:2015 + A11:2022

EN 62841-4-1:2020

EN ISO 12100: 2010

ISO 17080:2005

EN ISO 11681-2:2011 + A1:2017

ISO 11680-1:2021

ISO 9518:2018

NOTE: Where these standards are referenced below, the issue date is not repeated.

Clause	Requirement + Test	Result - Remark	Verdict
1	General safety requirements:		—
	Pruner saws shall comply with the requirements of EN 62841-1 as far as reasonably applicable. In addition, they shall comply with the requirements of this document, which are an adaptation from EN 62841-4-1. The definitions, general test conditions and cross-references (if cited) of these standards apply.		
	The following shall be considered regarding EN 62841-1: Clause 23.3: Protective devices shall be non-self-resetting.		
	In addition to the listed safety requirements of this test specification, a risk analysis according to EN ISO 12100 shall be presented. The risk assessment shall be reviewed for completeness and conclusiveness.		
	Pruner saws shall be designed according to the principles of EN ISO 12100 for relevant but not significant hazards, which are not dealt with by this document. It includes evaluation of such risks for all relevant components.		
2	Marking		—
	The designation of products according to this test specification are not allowed to be: "Mini chain saw" or equal.		
	Pruner saws shall be marked according to EN 62841-1. In addition, the following shall be marked (Ref. EN 62841-4-1, 8.2: <ul style="list-style-type: none"> • Always use pruner saw two-handed (text or symbol) • specified nominal guide bar size or size range (SI-Unit) 		
	Pruner saws shall be marked with safety information which shall be written in one of the official languages of the country in which the machine is to be sold or marked with the appropriate symbol:		—
	– "Wear eye protection" or a relevant safety sign of ISO 7010 or the safety sign specified in Annex AA;		
	– "Wear ear protection", a relevant safety sign of ISO 7010 or the safety sign specified in Annex AA. This marking may be omitted if the measured sound pressure level at the operator's ear in accordance with Annex I does not exceed 85 dB(A).		
	A combination of ISO safety signs, such as eye, ear, dust and head protection, is allowed. In addition, a combination of safety signs as specified in Annex AA is allowed.		
	– "Do not expose to rain" or the safety sign specified in Annex AA, unless the pruner saw has a degree of protection of at least IPX4.		
	– "Beware of pruner saw kickback and avoid contact with bar tip", or A.1.3 of ISO 17080.		

Clause	Requirement + Test	Result - Remark	Verdict
	– “Always use pruner saw two-handed” or A.3.1 of ISO 17080.		
	Addition:		—
	Pruner saws marked with the following:		
	– specified nominal guide bar size or size range;		
	– identification of the direction of rotation of the saw chain by a legible and durable mark on the body of the machine. This may be located under the drive sprocket cover.		
3	Instructions		—
3.1	Safety instructions for pruner saws in addition to EN 62841-1 and EN 62841-4-1		—
	<p>The instruction manual and safety instructions shall cover supplementary to the clause 8.14 of EN 62841-1 the subsense of the following:</p> <ul style="list-style-type: none"> • Wear work gloves • Wear head protection if there is a risk that falling branches could cause injuries • Wear robust working pants • Explanation of the correct working position of the two hands • Explanation regarding reactive forces like pulling in, pushing back and kicking up when cutting with the guide bar tip. • Further instructions of EN 62841-4-1 and EN ISO 11681-2, if applicable or necessary. • Type of guide bar and saw chain 		
3.2	Safety instructions for pruner saws of EN 62841-4-1; 8.14.1.101, as applicable		—
3.2.1	General pruner saw safety warnings:		—
	a) Keep all parts of the body away from the saw chain when the pruner saw is operating. Before you start the pruner saw, make sure the saw chain is not contacting anything. A moment of inattention while operating pruner saws may cause entanglement of your clothing or body with the saw chain.		
	b) Always hold the pruner saw with one hand on the control handle and the other hand on the auxiliary handle		
	c) Hold the pruner saw by insulated gripping surfaces only, because the saw chain may contact hidden wiring. Saw chains contacting a "live" wire may make exposed metal parts of the pruner saw "live" and could give the operator an electric shock.		
	d) Wear eye protection. Further protective equipment for hearing, head, hands, legs and feet is recommended. Adequate protective equipment will reduce personal injury from flying debris or accidental contact with the saw chain.		
	e) Do not operate a pruner saw in a tree, on a ladder, from a rooftop, or any unstable support. Operation of a pruner saw in this manner could result in serious personal injury.		

Clause	Requirement + Test	Result - Remark	Verdict
	f) Always keep proper footing and operate the pruner saw only when standing on fixed, secure and level surface. Slippery or unstable surfaces may cause a loss of balance or control of the pruner saw.		
	g) When cutting a branch that is under tension, be alert for spring back. When the tension in the wood fibres is released, the spring loaded branch may strike the operator and/or throw the pruner saw out of control.		
	h) Use extreme caution when cutting brush and saplings. The slender material may catch the saw chain and be whipped toward you or pull you off balance.		
	i) Carry the pruner saw with the pruner saw switched off and away from your body. When transporting or storing the pruner saw, always fit the guide bar cover. Proper handling of the pruner saw will reduce the likelihood of accidental contact with the moving saw chain.		
	j) Follow instructions for lubricating, chain tensioning and changing the bar and chain. Improperly tensioned or lubricated chain may either break or increase the chance for kickback.		
	k) Cut wood only. Do not use pruner saw for purposes not intended. For example: do not use pruner saw for cutting metal, plastic, masonry or non-wood building materials. Use of the pruner saw for operations different than intended could result in a hazardous situation.		
	l) This pruner saw is not intended for tree felling. Use of the pruner saw for operations different than intended could result in serious injury to the operator or bystanders.		
	m) Follow all instructions when clearing jammed material, storing or servicing the pruner saw. Make sure the switch is off and the battery pack is removed. NOTE 1 The above warning is used for machines with separable batteries or detachable batteries.		
	n) Follow all instructions when clearing jammed material, storing or servicing the pruner saw. Make sure the switch is off and the lock-off is in the locked position. NOTE 2 The above warning is used for machines with integral batteries .		
3.2.2	Causes and operator prevention of kickback:		—
	Kickback may occur when the nose or tip of the guide bar touches an object, or when the wood closes in and pinches the saw chain in the cut.		
	Tip contact in some cases may cause a sudden reverse reaction, kicking the guide bar up and back towards the operator.		
	Pinching the saw chain along the top of the guide bar may push the guide bar rapidly back towards the operator.		

Clause	Requirement + Test	Result - Remark	Verdict
	Either of these reactions may cause you to lose control of the saw which could result in serious personal injury. Do not rely exclusively upon the safety devices built into your saw. As a pruner saw user, you should take several steps to keep your cutting jobs free from accident or injury.		
	Kickback is the result of pruner saw misuse and/or incorrect operating procedures or conditions and can be avoided by taking proper precautions as given below:		
	a) Maintain a firm grip, with thumbs and fingers encircling the pruner saw handles, with both hands on the saw and position your body and arm to allow you to resist kickback forces. Kickback forces can be controlled by the operator, if proper precautions are taken. Do not let go of the pruner saw.		
	b1) Do not overreach and do not cut above shoulder height. This helps prevent unintended tip contact and enables better control of the pruner saw in unexpected situations. The above warning shall be omitted for pruner saws designed for the attachment of an extension pole.		
	b2) Do not overreach and do not cut above shoulder height unless the extension pole is mounted. This helps prevent unintended tip contact and enables better control of the pruner saw in unexpected situations. The above warning shall be omitted for pruner saws not designed for the attachment of an extension pole.		
	c) Only use replacement guide bars and saw chains specified by the manufacturer. Incorrect replacement guide bars and saw chains may cause chain breakage and/or kickback.		
	d) Follow the manufacturer's sharpening and maintenance instructions for the saw chain. Decreasing the depth gauge height can lead to increased kickback.		
3.3	Further instructions for pruner saws in addition to 8.14.2 of EN 62841-1		—
3.3.1	Instructions for putting into use in addition to 8.14.2 a) of EN 62841-1:		—
	101) Explanation of pruner saw safety devices;		
	102) Instructions for properly installing and adjusting the guide bar and saw chain;		
	103) Instruction for selection and use of protective equipment for eyes, ears, head, hands, legs and feet, as applicable.		
	Addition of 8.14.2 b) of EN 62841-1:		—
	105) Instructions to explain the proper techniques for basic working with the pruner saw		
	106) If applicable, instruction on the use of a manual lubrication control;		

Clause	Requirement + Test	Result - Remark	Verdict
	107) If applicable, instruction not to operate the pruner saw without lubrication and to replenish it in due time before the container is empty;		
	108) Instruction to use only recommended lubricants;		
	109) Information on the maximum speed of the saw chain.		
3.3.2	Operating instructions in addition to K.8.14.2 b) of EN 62841-1:		
	Instructions for the use and adjustment of any means of support for separable battery packs and instructions for release or removal.		
	Items 101) and 102) of K.8.14.2 b) in EN 62841-4-1 are not applicable.		
3.3.3	Maintenance and servicing instructions in addition to 8.14.2 c) of EN 62841-1:		—
	Information on recommended guide bar and saw chain combination(s) that can be used and that maintains compliance with this standard;		
	Instructions on sharpening and maintenance of the saw chain and/or a recommendation to have sharpening and maintenance of the saw chain performed by authorised service centres.		
3.3.4	Modification of K.8.14.3 of EN 62841-1 (adapted from EN 62841-4-1)::		—
	If information about the mass or weight of the pruner saw is provided, it shall be the mass of the machine without the saw chain, guide bar, guide bar cover, oil, battery and optional accessories. If information about the mass or weight of the battery(ies) is provided, it shall cover the range of specified batteries.		
4	Run-down time		—
	(Adapted from EN 62841-4-1, 19.112): The following requirements for run-down time shall be fulfilled. Note: A manual chain brake is not required.		
	The run-down time of the saw chain shall not exceed 2 s for the first 6 cycles of operation and shall not exceed 3 s for the final 6 cycles of the test sequence.		
	For the measurement, the saw chain tension shall be adjusted as for normal use. The machine shall be run in before starting the test by performing 10 “on”/“off” cycles with the power switch. One cycle consists of 30 s running and 30 s rest. After the run-in, the saw chain tension shall be adjusted according to the manufacturer’s recommendations. If no recommendations are provided, the saw chain tension shall generally be adjusted so that, when a 1 kg mass is hanging from the centre of the cutting length along the lower portion of the chain, the gap between the saw chain side link and the guide bar is a maximum of 0,017 mm per millimetre of guide bar length.		

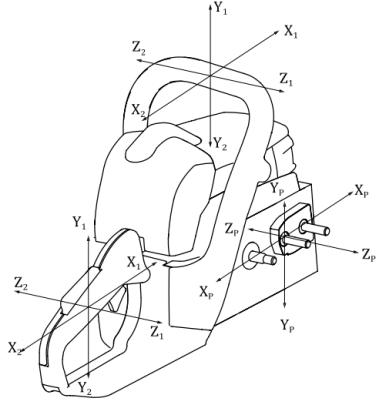
Clause	Requirement + Test	Result - Remark	Verdict
	The test is made under no-load. The test sequence shall consist of a total of 2 500 cycles for machines that rely on the operation of a braking mechanism in order to comply with the requirement.		
	For machines that do not rely on the operation of a braking mechanism in order to comply with the requirement, but comply with the requirement due to friction of the saw chain alone or which have active electronic braking where no wear of mechanical components is to be expected, the cycle number is reduced to 100.		
	The stop time is measured from the moment of release of the power switch actuator until the saw chain is stopped.		
5	Protection against access to the saw chain		—
	<p>It shall not be possible to reach the saw chain with fingers projecting from a handle, when holding the machine as instructed. If the distance between a handle and the saw chain is less than 120 mm a barrier is required to prevent straight line access to the saw chain.</p> <p>Such barriers may be fixed or movable.</p> <p>Dependent on the design, they shall comply with the requirements in 5.1 to 5.3 below.</p>		
5.1	<p>A moveable barrier, if any, shall have adequate mechanical strength in three directions according to ISO 7915, Fig. 1) and shall not break during the test.</p> <p>Movable barriers are tested in the rest position.</p> <p>Compliance is checked by the following tests with the guide bar removed.</p>	 <p>Figure 1 — Directions of load applications for chain-saws for forest service</p>	
	The tool is rigidly supported and a 50 N horizontal force (X) is applied at the front end of the barrier for 30 s pulling and 30 s pushing.		
	<p>The tool is rigidly supported and a 50 N downward force (Y) is applied to the barrier in the middle of the cutting length.</p> <p>Note: Cutting length according to EN 62841-4-1, Figure 102.</p>		
	<p>The tool is rigidly supported and a 20 N horizontal force (Z) is applied at the barrier in the middle of the cutting length for 30 s.</p> <p>Note: Cutting length according to EN 62841-4-1, Figure 102.</p>		

Clause	Requirement + Test	Result - Remark	Verdict
5.2	Movable barriers shall be cycled 50.000 times over their maximum range of movement. Afterwards their function shall not be impaired and they still shall travel to their intended rest position without manual intervention.		
5.3	Fixed barriers (e.g. in analogy to front hand guards for hedge trimmer (EN 62841-4-2) shall withstand the mechanical strength requirements according to EN 62841-1, clause 20.		
6	Guide bar cover		—
	(Adapted from EN 62841-4-1, 19.108) A protective cover shall be provided with the machine to cover the guide bar in order to prevent injuries during transportation and storage.		
	The guide bar cover shall not be displaced by more than 50 mm when the guide bar is in a vertical downward position.		
	When the guide bar is adjusted to its maximum length and the guide bar cover is fully engaged on the guide bar, no more than 50 mm of the saw chain on the top or bottom of the guide bar shall remain exposed.		
7	Drive sprocket cover		—
7.1	(Adapted from EN 62841-4-1, 19.9) If, in accordance with the instruction manual, the user is instructed to remove a drive sprocket cover, such as for maintenance, to change the saw chain or guide bar, then the fastenings shall remain attached to the drive sprocket cover or to the machinery, unless the drive sprocket cover fastenings are the only means for retaining the guide bar. If a fastening is not removed for removing the drive sprocket cover, it is considered as still attached.		

Clause	Requirement + Test	Result - Remark	Verdict
7.2	<p>(Adapted from EN 62841-4-1, 19.104)</p> <p>The drive sprocket and saw chain shall be covered within the area of the body of the pruner saw. This cover shall not be removable without the aid of a tool unless the drive sprocket cover fastenings are the only means for retaining the guide bar.</p> <p>There may be openings at the front, the front upper section and the bottom section to allow the ejection of wood chips and to allow passage of the guide bar and saw chain.</p> <p>Compliance is checked by inspection and by the following test:</p> <p>With the drive sprocket cover, guide bar and saw chain fitted, it shall not be possible to touch the drive sprocket and saw chain with the straight test probe (test probe of Figure 105 of EN 62841-4-1) introduced with a force in axial direction not exceeding 5 N from the top, the rear and the sides of the drive sprocket cover within the area of the body of the pruner saw.</p>		
	The sprocket cover shall not be removable without the aid of a tool, unless the drive sprocket cover fastenings are the only means for retaining the guide bar.		—
8	Handles		—
8.1	<p>Pruner saws shall be fitted with at least two handles to provide safe control.</p> <ul style="list-style-type: none"> • The control handle, which accommodates the power switch; and • an auxiliary handle to get the other hand in a safe position and to support precise guidance of the machine when cutting. 		
	No other parts of the machinery except the handles shall be designed / shaped in such a way to considered as gripping areas.		
	The min. length of the control handle shall be 100mm		
	<p>The control handle of pruner saws shall be of durable construction and capable of withstanding stress sustained under normal working conditions.</p> <p>Compliance is checked by the handle strength test of ISO 7915, the test forces for chain saws for tree service shall apply, corrected by factor F.</p> <p>$F = \text{actual cutting length in mm} / 300 \text{ mm.}$</p>		
8.2	<p>(Adapted from EN 62841-4-1, 19.101, 102, 103)</p> <p>The handle surfaces are designed and shaped that firm grip may be applied.</p>		
	<p>Perimeter of the cross-section of the control handle</p> <ul style="list-style-type: none"> - minimum 65 mm (ISO 7914, dimension H); - maximum 170 mm. 		

Clause	Requirement + Test	Result - Remark	Verdict
	Finger clearance at the released power switch (ISO 7914, dimension E) - minimum 30 mm		
	Clearance below the released power switch (ISO 7914, dimension F ₂): - minimum 25 mm		
	Finger clearance in the grip area (ISO 7914, dimension A): - minimum 35 mm		
	Behind the released power switch, there shall be a minimum of 3 × 25 mm gripping area (ISO 7914:2012, dimension G ₂)		
9	Hand protection		
	<p>The hand at the control handle shall be protected from injury, in case the chain derails.</p> <p>Protection may be achieved in the following ways:</p> <ul style="list-style-type: none"> • The derailed chain is not long enough to reach any finger at the control handle; or • guarding is provided as a shield to protect the fingers from injury. Such guarding shall project at least 30 mm over the gripping surface on the guide bar side of the control handle and be sufficiently long according to the reach of the derailed chain; or • any other construction prevents the operator's hand from contacting the saw chain. 		
10	KICKBACK:		—

Clause	Requirement + Test	Result - Remark	Verdict
	<p>Pruner saws shall not present a risk of injury due to kickback, when cutting wood with the tip of the guide bar. Compliance can be achieved by either fulfilling option 1) or 2) below:</p> <p>1) A bar tip guard shall protect the periphery of the saw chain at the tip of the guide bar. The bar tip guard shall be</p> <ol style="list-style-type: none"> a) part of the machine, not removable during user maintenance, and designed to prevent contact of any part of the saw chain; or b) part of a special chain bar which is not interchangeable with standard chain bar constructions. <p>Tip guards mounted on the guide bar are not accepted for this purpose, considering the foreseeable replacement by another guide bar without a tip guard. Such tip guard would need to be removed prior to the kickback test.</p> <p>2) Unless contact with the upper quadrant of the guide bar tip is prevented by constructive protective measures, the applied risk reduction measures shall be verified by the following test(s):</p> <p>Three experienced pruner saw experts (e.g., who completed vocational training) shall test the pruner saw with test specimens according to ISO 9518 clause 4.3.6, cutting with the bar tip perpendicular to the grain.</p> <p>They shall agree on whether the risk of injury can be considered as sufficiently minimized or not. When assessing a pruner saw, there will always be a reactive force upwards when cutting with the tip. However, the crucial considerations are as to</p> <ul style="list-style-type: none"> - whether the force is of a magnitude that it cannot easily be controlled; and - whether it could occur suddenly, such that the user is likely to be caught off guard and lose control of the machine. 		
	<p>Note: At this point, no established method is available to quantify kickback for pruner saws. As soon as such a method has been identified, this requirement will be updated.</p>		—
11	Saw chain tension		—
	<p>(Adapted from EN 62841-4-1, 19.109) Pruner saws with a nominal cutting length of 150 mm and above shall be provided with means of tensioning the saw chain.</p>		
12	Saw chain lubrication		—
	<p>Pruner saws shall be provided with a means for lubricating the saw chain. It is not required that a lubricant reservoir is an integral part of the machine.</p>		
13	Requirements for the power switch		—

Clause	Requirement + Test	Result - Remark	Verdict
13.1	(Adapted from EN 62841-4-1, 21.18.101) The power switch shall be a momentary power switch without a lock-on device, which can be switched on and off by the user without the need to release any of the handle(s) or grasping surface(s).		
	When the lock-off function is in the unlocked state, the pruner saw shall operate within 1 s after actuation of the power switch.		
13.2	(Adapted from EN 62841-4-1, 21.18.102) The machine shall be provided with a power switch having a lock-off device such that at least two separate and dissimilar actions are required before drive to the saw chain is possible. It shall not be possible to achieve these actions with a single grasping motion or a straight-line motion within any grasping surface.		
	The lock-off device shall be actuated before the power switch can enable drive to the saw chain.		
	It shall not be necessary to sustain the actuation of the lock-off device until the power switch is activated, provided:		—
	– the power switch or an operator presence sensor (if any) is activated within 5 s of the release of the lock-off device; and		
	– there is a visual or audible indication as soon as the lock-off actuator is released and continues at least until the power switch is activated; or		
	– an operator presence sensor (if any) is activated prior to the release of the actuator of the lock-off device.		
	The machine shall return to the original locked state within 1 s when the power switch is released (i.e. at least two separate and dissimilar actions are required before drive to the saw chain is possible), unless:		—
	– an operator presence sensor is provided; and		
	– the hand is not released from the operator presence sensor.		
	Additionally, for a lock-off device located within any grasping surface identified in accordance with the instructions, in order to determine if it is possible to actuate the power switch and the lock-off device with a single grasping motion or a straight-line motion, compliance is checked by the following test:		
	The lock-off device, if located within any grasping surface, shall not be actuated by a 25 mm diameter x 75 mm long rod with a force not exceeding 20 N on the lock-off device in any direction.		
	The rod shall be applied such that its cylindrical surface bridges the surface of the lock-off device and any surface adjacent to the lock-off device.		

Clause	Requirement + Test	Result - Remark	Verdict
	It shall not be possible to operate the power switch under these conditions.		
13.3	Pruner saws shall be designed to allow operation of the power switch either by the right or the left hand		
13.4	(Adapted from EN 62841-4-1, 21.102) The operator presence sensor, if any, shall be incorporated in the control handle. It is not required that the operator presence sensor is capable of distinguishing between an operator's hand and other objects. The function of the operator presence sensor may be achieved by any combination of mechanical, electrical or electronic means.		
14	Mechanical strength		—
14.1	(Adapted from EN 62841-1, K.20.1) Following the test, the pruner saw and battery pack shall not catch fire or explode and shall comply with the requirements for mechanical safety and electrical safety. The open circuit voltage of the battery shall not be less than 90 % of the voltage measured prior to the test. The battery shall demonstrate normal discharging and recharging after the test. The cell vent shall not be impaired in a way that the cell protection is in jeopardy.		
	(Adapted from EN 62841-4-1, 20.1) Damage to the guide bar and saw chain is ignored.		
	A tank cap, if any, that comes off as a result of the test, but can be put back in place and did not get damaged is not considered a failure.		
	For integral lubrication systems, there shall be no leakage of lubrication through cracks in lubrication tanks and tank caps while the pruner saw is being held in each of the six orthogonal directions for 30 s. Seepage through ventilation systems is not considered a failure.		
14.2	(Adapted from EN 62841-4-1, K.20.3.1) The pruner saw, fully assembled in accordance with the instruction manual and with the lubrication tank empty, if any, with any detachable battery pack attached is dropped three times in total on a concrete surface from a height of 1 m.		
	For these three drops, the sample is tested in the three most unfavourable positions the lowest point of the tool being 1 m above the concrete surface. Secondary impacts shall be avoided.		

Clause	Requirement + Test	Result - Remark	Verdict
	If attachments, other than alternative guide bars and saw chains, are provided as specified and mounted in accordance with the instruction manual, the test is repeated with each attachment or combination of attachments mounted to a separate machine sample.		
	For battery machines with detachable battery packs, the test is repeated three more times without the battery pack attached to the machine. New samples may be used for each series of three drops.		
	In addition for detachable battery packs or separable battery packs, the test is repeated three more times on the battery packs separately.		
	If attachments, other than alternative guide bars and saw chains, are provided as specified and mounted in accordance with the instruction manual, the test is repeated with each attachment or combination of attachments mounted to a separate machine sample with a detachable battery pack or separable battery pack installed.		
	After the test, the lubrication tank, if any, is filled to the maximum level in accordance with the instruction manual.		
15	Electronic circuits providing safety critical functions (SCF) (Adapted from EN 62841-4-1, 18.8)		—
	Electronic circuits providing SCF shall be reliable and not susceptible to loss of the SCF due to electromagnetic environmental stresses. The requirements of EN 62841-1 clause 18.8 apply together with the Performance Levels (PL) as specified at the end of this document.		
16	Additional requirements for tools with extension pole		—
16.1	Pruner saws, intended to be supported via an extension pole and thus being convertible into a pole-mounted powered pruner, shall comply with the following requirements as adapted from EN ISO 11680-1.		
16.2	Handles		—
	The machine shall have a handle for each hand. The shape and surface of the handle shall be designed such as to provide the necessary sureness of grip with and without gloves. The gripping length shall be at least 100 mm. The gripping length of a bail or closed handle shall comprise any length that is straight or curved at a radius greater than 100 mm together with any blend radius, but not more than 10 mm, at one or both ends of the gripping surface. The design and dimensions shall be verified by inspection and measurement.		
16.3	Distance to cutting attachment		—

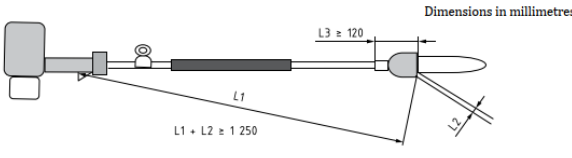
Clause	Requirement + Test	Result - Remark	Verdict
	<p>The distance, L, from the rear of the power switch to the nearest unguarded point of the cutting attachment shall be at least 1 250 mm, if applicable measured as a chain measurement (L1 + L2), with the cutting attachment adjusted to its position nearest to the operator (see Figure 4).</p> <p>If the location of the power switch throttle trigger is adjustable, any adjustment below the distance of 1 250 mm shall be prevented by design.</p> <p>This minimum distance from the rear of the power switch throttle trigger to the nearest unguarded point of the cutting attachment shall apply to all cutting attachments recommended by the manufacturer.</p> <p>A fixed obstacle (e.g. the gear case or a collar on the shaft tube) shall be provided close to the cutting attachment to indicate to the operator that his hand is getting close to the cutting attachment. The distance from the rear of the fixed obstacle to the nearest unguarded point of the cutting attachment (L3) shall be at least 120 mm, measured as a chain measurement.</p> 		
16.4	Mechanical strength		—
16.4.1	<p>The mechanical connection between the pruner saw and the extension pole shall be reliable to withstand loads as experienced in normal use.</p> <p>The pruner saw is suspended at the guide bar in such a way that the pole hangs down vertically. A mass of 20 kg is attached to the rear handle of the pole without jerks for 1 minute.</p> <p>The pruner saw shall not separate from the extension pole; there shall be no damage to the saw or the pole impairing further use.</p>		
16.4.2	<p>The means for connecting the pruner saw to the extension pole shall be such that incorrect fitting and securing is obviated by design as far as reasonably possible. Correct securement shall be clearly recognizable.</p>		
16.4.3	<p>The clamping of the pruner saw to the extension pole shall be protected against inadvertent release.</p> <p>The clamping release shall not project over the contour of the surrounding surface to prevent inadvertent release of the clamping means. One way of checking whether the release projects is the use of a straight edge across the release mechanism.</p> <p>Clamping achieved by means of a hand-operated screw is acceptable at least five revolutions are needed to release the clamping.</p>		
16.4.4	<p>The controls at the extension pole shall comply with the requirements in section 13 above.</p>		

Clause	Requirement + Test	Result - Remark	Verdict
	<p>(Adapted from EN 62841-4-5:2021 + A11:2021, clause 21.101):</p> <p>A removable extension shaft, if any, shall be provided with a power switch that overrides or duplicates the function of a power switch which may be located on the machine without an extension shaft.</p>		
16.4.5	<p>The pruner saw in conjunction with the extension pole shall be sufficiently robust to withstand rough handling as in normal use.</p> <p>A single sample, fully assembled, is subjected to one impact in an orientation where it might be weak. The extension pole shall be fully extended, the tank empty and the heaviest battery attached, as applicable.</p> <p>For the impact, the machine shall be suspended from a position (150 ± 2) mm in front of the middle of the rear handle and at a height of (775 ± 2) mm above a concrete surface. It shall point upwards at an angle of (45 ± 2)° and be able to swing freely around the point of suspension.</p> <p>After the impact, the lubrication tank, if any, is filled to the maximum level in accordance with the instruction manual. There shall be no leakage of lubrication through cracks in lubrication tanks and tank caps while the pruner saw is being held in each of the six orthogonal directions for 30 s. Seepage through the ventilation systems is not considered a failure.</p> <p>The pruner saw and battery pack shall not catch fire or explode and shall comply with the requirements for mechanical safety and electrical safety. The machine and the extension pole shall not separate.</p> <p>The open circuit voltage of the battery shall not be less than 90 % of the voltage measured prior to the test.</p> <p>The battery shall demonstrate normal discharging and recharging after the test.</p> <p>The cell vent shall not be impaired in a way that the cell protection is in jeopardy.</p> <p>Damage to the guide bar and the saw chain is ignored.</p>		
17	Noise & Vibration		—
	Noise according to EN 62841-4-1, clause I.2 (Test & Measuring at max. no-load speed only)		
	Vibration acc to EN 62841-4-1, clause I.3		
18	Moisture resistance		—
	Pruner saws with an IP moisture protection marking higher than IPX0 shall be tested according to the requirements for chain saws as specified in EN 62841-4-1:2020, clause K.14.		

TABLE: Performance levels of Safety Critical Functions			
Type and purpose of SCF	Min. PL determined based on: ^{1,2}	Min. PL	Actual PL
Power switch – prevent unwanted switch-on	EN 62841-4-1	Shall be evaluated using the fault conditions of 18.6.1 in EN 62841-1 without the loss of this SCF	
Power switch – provide desired switch-off	EN 62841-4-1	Shall be evaluated using the fault conditions of 18.6.1 in EN 62841-1 without the loss of this SCF	
Provide desired direction of rotation	EN 62841-4-1	a	
Overspeed prevention for pruner saws if such overspeed would cause a chain speed greater than 8 m/s	EN 62841-4-1	a	
Prevent exceeding the maximum run-down time	EN 62841-4-1	a	
Operator presence sensor as in 13.2	EN 62841-4-1	a	
Lock-off function as required by 13.2	EN 62841-4-1	b	
Prevent self-resetting as required in 23.3 of EN 62841-4-1	EN 62841-4-1	a	

	CO-ORDINATION OF NOTIFIED BODIES Machinery Directive 2006/42/EC + Amendment RECOMMENDATION FOR USE	CNB/M/03.002 Revision: 15 Language: E
Date of first stage: 24/09/1996	To be approved by:	Approved on:
Origin: VG3 Presses for cold working metals	<input checked="" type="checkbox"/> Vertical Group <input checked="" type="checkbox"/> Horizontal Committee.....	30/09/2009 12/12/1995
Question related to: Dir. 2006/42/EC Article: Annex: IV-9 EHSR (1):	EN/prEN: Normative clause: CEN TC concerned:	Other: Other clause:
Key words: Presses - Metal - Field of application		
Question: Which categories of metal presses are referred to in Annex IV A, point 9, of the "machines"?		
<p>Recommended Solution:</p> <p>1) By cold working it is understood that there is a possibility of the operator placing (loading) and/or removing (unloading) workpieces between the tools with his hands.</p> <p>2) By metal, it is understood to be a material, either in sheet, rolled conditions, or forged form. Powders, not necessarily metallic, irons, and concrete meshes are excluded from this definition.</p> <p>3) By cold metal working it is understood to be a transformation process either by folding, stamping, or cutting, etc.</p> <p>Only presses who's movable working parts are driven by an alternative movement having the two following constructional characteristics are referred to:</p> <ul style="list-style-type: none"> - a travel of greater than 6 mm, - a closing speed superior to 30 mm/sec. (see CNB/M/3/042) <p>Regarding mechanical presses, the instantaneous speed reached by the movable working parts at the mid-point of their travel during their ascent and descent should be taken into consideration, as it is maximum in either of these positions.</p>	<p>4) exclusion from annex IV A for the machines who's principal purpose is:</p> <ul style="list-style-type: none"> - sheet metal cutting by guillotine (guillotine shears), - attaching a fastener, e. g. riveting, stapling or stitching, fastening etc...(erection, dismantling machines), - assembling e. g. bearing (simple assembling presses), - bending or folding (bending machines, bending presses), - calibrating, - straightening (straightening presses, planing presses), - turret punch pressing (punching and nibbling machines), - extruding (extruder presses), - drop forging or drop stamping, - compaction of metal powder (presses for compacting powders), - punching (punching machines), - blow forging (blow forging presses), - isostatic forming (isostatic presses for metal powder, for complex parts of sheet material) <p>Note 1: Hot working of metals is understood if the operator is forced to use tongs or grippers etc. for handling of hot metals (workpieces) so that his hands are outside of the tools area and cannot be injured.</p> <p>Note 2: If hot metals (workpieces) are placed or removed by hand between the tools without ancillary devices, it is understood as cold working of metals.</p>	
Adaptation procedure: FORMAL ADAPTATION IN CONFORMITY WITH DIRECTIVE 2006/42/EC		

(1) Essential health and safety requirement

Note: According to point 6.6 of the Guide of the implementation of directives based on the New Approach and the Global Approach, the notified bodies apply as general guidance this recommendation for use.

	CO-ORDINATION OF NOTIFIED BODIES Machinery Directive 2006/42/EC + Amendment RECOMMENDATION FOR USE	CNB/M/03.004 Revision: 06 Language: E
Date of first stage: 13/12/1995	To be approved by:	Approved on:
Origin: VG3 Presses for cold working metals	<input checked="" type="checkbox"/> Vertical Group <input checked="" type="checkbox"/> Horizontal Committee.....	30/09/2009 12/12/1995
Question related to: Dir. 2006/42/EC Article: Annex: VI point 2 EHSR (1):	EN/prEN: Normative clause: CEN TC concerned:	Other: Other clause:
Key words: Technical file		
Question: What shall be the contents of a press technical file?		
Solution: The content of the technical file is defined by annex VI point 2 of the directive. It may particularly understand : <u>1st dash</u> (related to the annex VI point 2 about the technical file) - Dimensions of the machine related to the protective means (general drawings with dimensions of accesses to the dangerous parts), - Location diagram of the electrical components on the press (in the cabinet, on the frame...) - Location diagram of the hydraulic and pneumatic components <u>2nd dash</u> - Functional schemes of the control circuits (hydraulic, electric, pneumatic, mechanic...), - Description of the time sequences, e.g. functional characteristics of the valves - Diagrams for cams, selector switches, - A components list with data sheets and instructions for use of certified safety components. - Drawings of the guards (dimensions, material, cams, attachments...), - Drawings of the power flow related to the safety (flywheel, slide, piston, ejectors, handling devices...), - Positioning of the controls (selector switches, emergency stops, pedal...), - Positioning of the guards and the protective devices to check the possibilities of accesses, - Calculations or references about experiences with well tried components..., (see separate technical sheet n° ...) - Declaration of conformity for safety components. - Notes, results, tests (for example stopping time) - Declaration of conformity with the EMC directive from the 1 st /01/96 (see CNB/M/006/R and CNB/M/3/021/R) - Declaration of conformity with the low voltage directive from the 1 st /01/97 (see CNB/M/3/067/R) - Declaration of conformity with others related directives concerning hazardous aspects		

(1) Essential safety requirement

Note: According to point 6.6 of the Guide of the implementation of directives based on the New Approach and the Global Approach, the notified bodies apply as general guidance this recommendation for use.

3rd dash

As parts of the risk assessment, the designer shall verify whether the list of hazards in table 1 of Pr EN692, 693, ... is exhaustive and applicable to the press under consideration.

If additional hazard is identified the risk assessment has to be carried out and the measures taken to eliminate or reduce this risk shall to be described

4st dash

Recommendation for the handbook:

- Where the protective means are described, the associated safety instructions shall be also given and highlighted.

It shall be, at least, one clause containing safety instructions, with reference to the description of the protective devices.

- The instruction handbook may give additional information.

5st dash

See technical sheet CNB/M/00.240/R/E (03.003).

Adaptation procedure: FORMAL ADAPTATION IN CONFORMITY WITH DIRECTIVE 2006/42/EC

	CO-ORDINATION OF NOTIFIED BODIES Machinery Directive 2006/42/EC + Amendment RECOMMENDATION FOR USE	CNB/M/03.013 Revision 08 Language: E
Date of first stage: 13/10/1997	To be approved by:	Approved on:
Origin: VG3 Presses for cold working metals	<input checked="" type="checkbox"/> Vertical Group	13/10/2010
	<input checked="" type="checkbox"/> Horizontal Committee	14/12/2010
Question related to: Directive 2006/42/EC Article: 5 Annex: IX ESR (1):	EN/prEN:	Other:
	Clause:	Other clause:
	CEN TC concerned:	
Key words: Acceptability of components of type examined presses		
<p>Question:</p> <p>If a:</p> <ul style="list-style-type: none"> - two hand control device - active opto-electronic protective device - cyclic moving interlocking guard - rotary cam gear - control system - overrun detection - etc <p>is examined within a EC Type-Examination of a press, should the results be respected and accepted by other notified bodies testing other presses (also of other press manufacturers) in relation to the above mentioned components ?</p>		
<p>Solution:</p> <p>Normally not.</p> <p>However, if there are separate certificates for single components, the following shall be taken in consideration :</p> <ol style="list-style-type: none"> 1 - Certificates of notified bodies for safety components, established in Annex IV, shall be accepted by notified bodies for presses. 2 - Certificates of accredited Test and Certification bodies for (safety) components may be accepted by notified bodies for presses. <p>Notes :</p> <ul style="list-style-type: none"> - The notified body examining a press should have all the necessary technical data for installation and operation of the component. - This RfU is valid only for the safety components assessed under machinery Directive. 		

(1) Essential safety requirement

Note: According to point 6.6 of the Guide of the implementation of directives based on the New Approach and the Global Approach, the notified bodies apply as general guidance this recommendation for use.

	CO-ORDINATION OF NOTIFIED BODIES Machinery Directive 2006/42/EC + amendments RECOMMENDATION FOR USE		CNB/M/03.027 Revision: 09 Language: EN
Number of pages: 1	Date: 03.07.2023	To be approved by:	Approved on:
Origin: VG3 Presses for cold working metals		<input checked="" type="checkbox"/> Vertical Group <input checked="" type="checkbox"/> Horizontal Committee To be endorsed by: <input checked="" type="checkbox"/> Machinery Expert Group	19.09.2019 14.06.2022 Endorsed on: 23.03.2023
Question related to: Directive 2006/42/EC	Article: - Annex: I EHSR (1): 1.2.2	EN/prEN: EN ISO 16092-1:2018 Normative clause: 5.3.2.14 CEN TC concerned: CEN/TC143 + ISO/TC39 SC10	Other: - Other clause: -
Key words: Secondary protection / Two Hands Control Device / Active Optoelectronic Protective Devices			
Question: If a large press is safeguarded by light curtains and the tools area has to be entered by operators, which can be a sufficient protection? Normally, the table height is less than 750 mm, sometimes zero. Considering the recommended solution, may a single push button with reset function be an acceptable level of protection?			
Solution: Yes, if there is a good visibility of the dangerous area form the resetting point. Otherwise the following measures have to be adopted: <ol style="list-style-type: none"> 1. The light curtain can act here only as a secondary protection measure to protect third persons. 2. Each operator has to use a two hand control device (THCD) type IIIC to initiate the stroke. 3. Each two hand control device requires a synchronous operation, the THCD's one with another require only simultaneous operation. <p>After an interruption of the light curtain, during the dangerous movement, the reset function has to be actuated before further movement can be initiated as described above.</p>			

(1) Essential health and safety requirement

Note: According to point 6.6 of the Guide of the implementation of directives based on the New Approach and the Global Approach, the notified bodies apply as general guidance this recommendation for use.

	CO-ORDINATION OF NOTIFIED BODIES Machinery Directive 2006/42/EC + amendment RECOMMENDATION FOR USE		CNB/M/03.029 Revision 04 Language: E
Date of first stage: 13/10/1997 Origin: VG3 Presses for cold working metals		To be approved by: <input checked="" type="checkbox"/> Vertical Group <input checked="" type="checkbox"/> Horizontal Committee..... To be endorsed by : <input checked="" type="checkbox"/> Machinery Working Group.	Approved on: 30/09/2009 12/12/1995 Endorsed on : 04/06/1996
Question related to: Dir. 2006/42/EC Annex: I	Article: EHSR (1): 1.3.8	EN/prEN: 692:2005+A1:2009, 693:2001+A1:2009 Normative clause: 5.3.13 (692 Annex C) CEN TC concerned: TC 143	Other: Other clause:
Key words: Reaching over, under and around the detection zone			
Question: Which tables of EN 13857 can be used to examine safety distances for reaching over, under and around the detection zone of a light Curtain?			
Solution: Reaching under and around the light curtain, tables 3, 4 and 6 shall be followed. Reaching over, table 1 may be used because there is no support for the arms by a physical guard; the light curtain will be interrupted using these correlating values. Adaptation procedure: FORMAL ADAPTATION IN CONFORMITY WITH DIRECTIVE 2006/42/EC			

(1) Essential health and safety requirement

Note: According to point 6.6 of the Guide of the implementation of directives based on the New Approach and the Global Approach, the notified bodies apply as general guidance this recommendation for use.

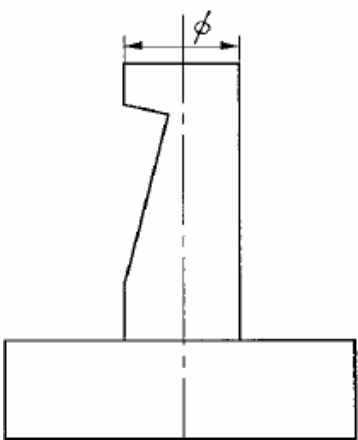
	CO-ORDINATION OF NOTIFIED BODIES Machinery Directive 2006/42/EC + amendments RECOMMENDATION FOR USE		CNB/M/03.032 Revision: 07 Language: EN
Number of pages: 1 Origin: VG3 Presses for cold working metals	Date: 03.07.2023	To be approved by: <input checked="" type="checkbox"/> Vertical Group <input checked="" type="checkbox"/> Horizontal Committee To be endorsed by: <input checked="" type="checkbox"/> Machinery Expert Group	Approved on: 24.05.2022 14.06.2022 Endorsed on: 23.03.2023
Question related to: Directive 2006/42/EC Annex: I	Article: - EHSR (1): 1.3.2	EN/prEN: EN ISO 16092-1:2018 Normative clause: 5.3.3.1 CEN TC concerned: TC 143 and ISO TC 39/SC 10	Other: - Other clause: -
Key words: Fixing the tools, failure of one component.			
Question: Sometimes, single components are used to fix the tool (rod, latch, screw). Which requirements a single component has to fulfil? (see illustration)			
Solution: One screw with a nut for blocking up will be sufficient if well-tried principles according to EN ISO 13849-2:2012 are considered (over-dimension, etc..). 			

(1) Essential health and safety requirement

Note: According to point 6.6 of the Guide of the implementation of directives based on the New Approach and the Global Approach, the notified bodies apply as general guidance this recommendation for use.

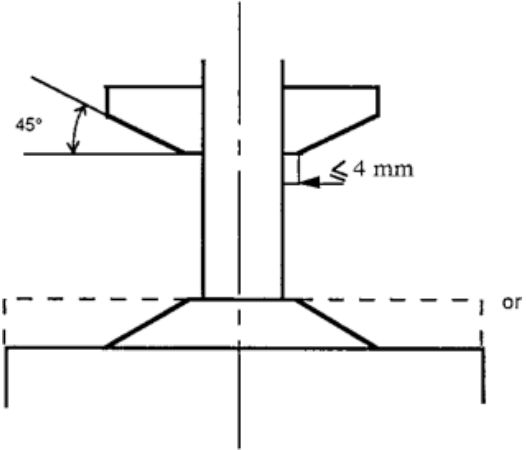
	CO-ORDINATION OF NOTIFIED BODIES Machinery Directive 2006/42/EC + amendments RECOMMENDATION FOR USE		CNB/M/03.035 Revision: 07 Language: EN
Number of pages: 3 Origin: VG3 Presses for cold working metals	Date: 03.07.2023	To be approved by: <input checked="" type="checkbox"/> Vertical Group <input checked="" type="checkbox"/> Horizontal Committee To be endorsed by: <input checked="" type="checkbox"/> Machinery Expert Group	Approved on: 24.05.2022 14.06.2022 Endorsed on: 23.03.2023
Question related to: Directive 2006/42/EC Annex: I	Article: - EHSR (1): 1.3.8	EN/prEN: EN ISO 16092-3:2018 Normative clause: 5.6 CEN TC concerned: TC 143 and ISO TC 39/SC 10	Other: - Other clause: -
Key words: crushing hazards, ram frame.			
Question: Small hydraulic presses often create a crushing hazard between the frame (bottom of the cylinder) and the ram. Which method is appropriate to avoid the hazard?			
Solution: See attached figures 1 to 5 and table 1 of standard EN ISO 13854:2020. If the head can be inserted, the distance shall be equal or more than 300 mm. <div style="text-align: center;">  </div> <p style="text-align: center;">Figure 1</p>			

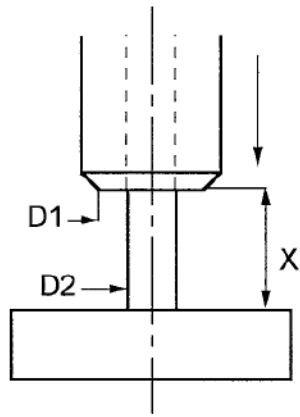

Figure 2

	D1 - D2	• 6 mm	X • 6 mm
6 mm <	D1 - D2	• 25 mm	X • 25 mm
25 mm <	D1 - D2	• 100 mm	X • 100 mm
100 <	D1 - D2	mm	X • 100 mm

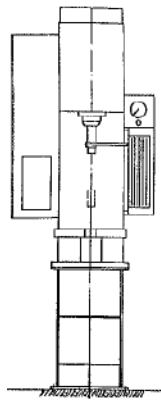

Figure 3

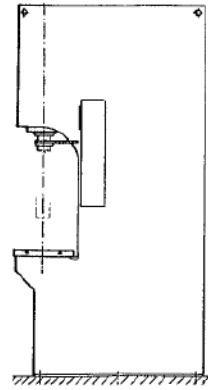
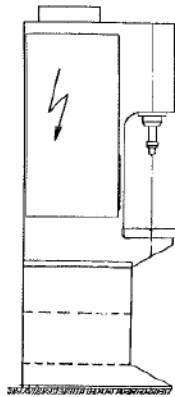
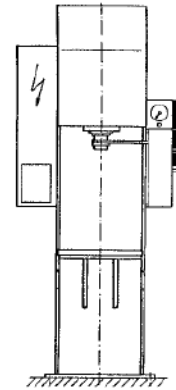

Figure 4



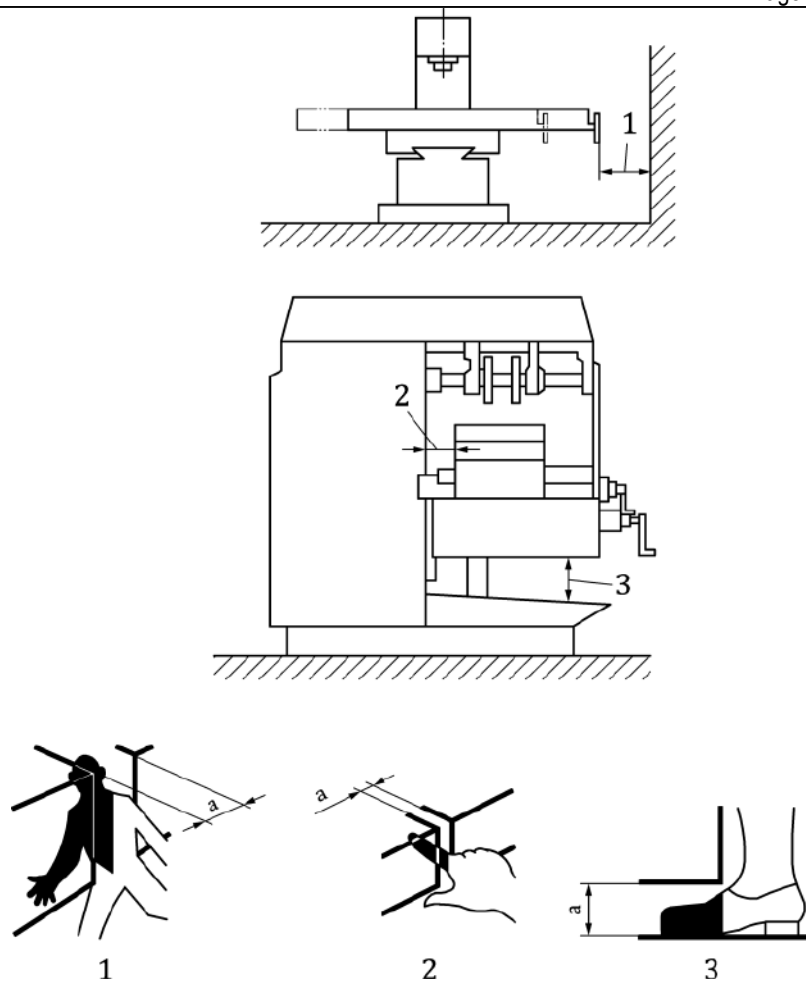



Fig.5 (fig. A.1 from EN ISO 13854)

(1) Essential health and safety requirement

Note: According to point 6.6 of the Guide of the implementation of directives based on the New Approach and the Global Approach, the notified bodies apply as general guidance this recommendation for use.

	CO-ORDINATION OF NOTIFIED BODIES Machinery Directive 2006/42/EC + amendments RECOMMENDATION FOR USE		CNB/M/03.111 Revision: 09 Language: EN
Number of pages: 1	Date: 03.07.2023	To be approved by:	Approved on:
Origin: VG3 Presses for cold working metals		<input checked="" type="checkbox"/> Vertical Group	12.09.2019
		<input checked="" type="checkbox"/> Horizontal Committee	14.06.2022
		To be endorsed by:	Endorsed on:
		<input checked="" type="checkbox"/> Machinery Expert Group	23.03.2023
Question related to: Directive 2006/42/EC	Article: -	EN/prEN: EN ISO 16092-3:2018	Other: -
Annex: I	EHSR (1): 1.3.8.2, 1.4.1, 1.4.3	Normative clause: Cl. 6, Table 3	Other clause: -
Key words: Stopping time measurement / die cushion / ejector			
Question: Will a stopping time measurement be required for die cushions or ejectors?			
Solution: No, not in general, but the risk assessment shall take into consideration if the measurement is needed or not. At the present time, the current standards do not require stopping time measurements for die cushions or ejectors.			

(1) Essential health and safety requirement

Note: According to point 6.6 of the Guide of the implementation of directives based on the New Approach and the Global Approach, the notified bodies apply as general guidance this recommendation for use.

	CO-ORDINATION OF NOTIFIED BODIES MACHINERY DIRECTIVE 2006/42/EC + Amendment RECOMMENDATION FOR USE	CNB/M/03.124 Revision 07 Language: E
Date of first stage: 25/08/1997	To be approved by:	Approved on:
Origin: VG3 Presses for cold working metals	<input checked="" type="checkbox"/> Vertical Group <input checked="" type="checkbox"/> Horizontal Committee..... To be endorsed by: <input checked="" type="checkbox"/> Machinery Working Group.	29/09/2009 21/11/2005 Endorsed on: 20/04/2006
Question related to: Dir. 2006/42/EC Article: Annex: I EHSR (1): 1.4.1	EN/prEN: EN 12622:2001 Normative clause: 5.3.22 CEN TC concerned: TC 143/WG1	Other: Other clause:
Key words: press-brakes / tandem assembly		
Question: Which requirements have to be achieved in the design if a tandem assembly of press brakes is used singly?		
Solution: When a tandem assembly of two press brakes is used singly, the singly used parts of the assembly have to fulfil the safety requirements which apply to single machines according to EN 12622, especially: a) The two machine control systems have to function separately. b) Between both press brakes, a guard and its position have to be activated (interlocking guard). c) The extension of the guard towards the operator measured from the bending line shall be at least 230 mm in accordance to the requirement for single press brakes as illustrated in the harmonised standard EN 12622, Annex F. d) This operational mode has to be selected e.g. by a separated selector switch or by separated positions of the existing mode selector.		
Adaptation procedure: FORMAL ADAPTATION IN CONFORMITY WITH DIRECTIVE 2006/42/EC		

(1) Essential health and safety requirement

Note: According to point 6.6 of the Guide of the implementation of directives based on the New Approach and the Global Approach, the notified bodies apply as general guidance this recommendation for use.

	CO-ORDINATION OF NOTIFIED BODIES MACHINERY DIRECTIVE 2006/42/EC + Amendment RECOMMENDATION FOR USE		CNB/M/03.128 Revision 08 Language: E
Date of first stage: 28/09/1998	To be approved by:		Approved on:
Origin: VG3 Presses for cold working metals	<input checked="" type="checkbox"/> Vertical Group <input checked="" type="checkbox"/> Horizontal Committee..... To be endorsed by: <input checked="" type="checkbox"/> Machinery Working Group		29/09/2009 09/06/2005 Endorsed on: 29/10/2005
Question related to: Dir. 2006/42/EC	Article:	EN/prEN: EN 693:2001 EN 12622:2001	Other: EN 954-1:1996
Annex: I	EHSR (1): 1.2.1	Normative clause:	Other clause:
CEN TC concerned: TC 143 WG 1			
Key words: Overlapping, Monitoring Valves			
Question :			
1.) Which positive overlapping of a (safety related) directional valve can be considered as proper? 2.) Have measures to be taken to test the position monitoring of valves? 3.) Is a binary output of the position monitoring of a proportional valve required or is an analogous output also acceptable?			
Answer :			
1.) The positive overlapping of a directional valve (e.g. restraint valve) shall ensure that the closing speed cannot exceed 1 mm/s as long as the directional valve is in resting position. The positive overlapping of a proportional valve should be bigger or equal than 0,35 mm. The positive overlapping of other directional valves should be equal or bigger than 0,5 mm. Manufacturing tolerances of the parts of the directional valve have to be taken into account. 2.) Measures to check the position monitoring of valves are not required. (The electronics of a position monitoring must conform to – at least- category B of EN 954-1.) The Change of signal must be monitored. 3.) An analogue output of the position monitoring of a proportional valve is acceptable. (The electronics of the position monitoring of a valve must conform to category B of EN 954-1.)			
Remark: If the protection for the operator is raised during the closing stroke all safety related valves must be separated from the electrical energy supply by opening contacts (except the gap between the tools does not exceed 6 mm).			
Note: Good experience have been made with a positive overlapping of a proportional valve equal or more than 0,35 mm and of a directional valve equal or more than 0,5 mm			
Adaptation procedure: FORMAL ADAPTATION IN CONFORMITY WITH DIRECTIVE 2006/42/EC			

(1) Essential health and safety requirement

Note: According to point 6.6 of the Guide of the implementation of directives based on the New Approach and the Global Approach, the notified bodies apply as general guidance this recommendation for use.

	<p>CO-ORDINATION OF NOTIFIED BODIES MACHINERY DIRECTIVE 2006/42/EC + Amendment</p> <p>RECOMMENDATION FOR USE</p>	<p>CNB/M/03.141 Revision 04 Language: E</p>
---	--	---

Date of first stage: 24/05/2000	To be approved by:	Approved on:
Origin: VG3 Presses for cold working metals	<input checked="" type="checkbox"/> Vertical Group..... <input checked="" type="checkbox"/> Horizontal Committee	29/09/2009 02/06/1999
	To be endorsed by:	Endorsed on:
	<input checked="" type="checkbox"/> Machinery Working Group.	03/03/2000

Question related to: Dir. 2006/42/EC Article:	EN/prEN: EN 693:2001+A1:2009	Other:
Annex: I EHSR (1): 1.2.1	Normative clause: 5.4	Other clause:
	CEN TC concerned: TC 143	

Key words: Bypassing monitored restraint valves

Question:
 Under which conditions bypassing a restraint valve is allowed?

Solution:
 1) The volume flow in the bypass shall be restricted to the value of $5 \text{ mm/s} \times A_R$ (ring area) of the cylinder, e.g. by a bleed (orifice plate)
 2) The check valve in the bypass can fail without any detection (see figure)
 3) If the second restraint valve fails also, the speed (leakage speed) of the beam/slide/ram shall not increase more than 5 mm/s (check valve failed already without detection)
 Note: The max. weight of slide/ram/beam with tools has to be taken into consideration

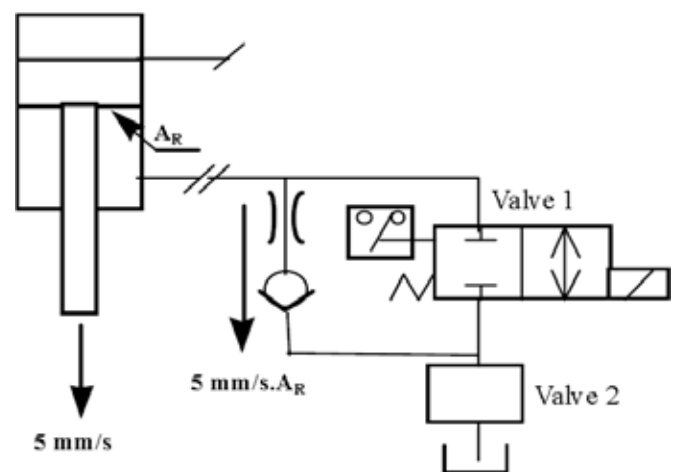

Adaptation procedure: FORMAL ADAPTATION IN CONFORMITY WITH DIRECTIVE 2006/42/EC

(1) Essential health and safety requirement
 Note: According to point 6.6 of the Guide of the implementation of directives based on the New Approach and the Global Approach, the notified bodies apply as general guidance this recommendation for use.

	CO-ORDINATION OF NOTIFIED BODIES Machinery Directive 2006/42/EC + Amendment RECOMMENDATION FOR USE	CNB/M/03.154 Revision 07 Language: E
Date of first stage: 25/03/2002	To be approved by:	
Origin: VG3 Presses for cold working metals	<input checked="" type="checkbox"/> Vertical Group	Approved on: 30/09/2009
	<input checked="" type="checkbox"/> Horizontal Committee.....	24/10/2002
Question related to: Dir. 2006/42/EC Article: Annex: I EHSR (1): 1.2.1, 1.6.1, 1.6.4	To be endorsed by:	
	<input checked="" type="checkbox"/> Machinery Working Group.	Endorsed on: 02/03/2004
	EN/prEN: EN 693:2001+A1:2009	Other:
	Normative clause: 5.2.1, 5.2.2	Other clause:
	CEN TC concerned: TC 143	
Key words: Hydraulic presses, Mechanical restraint device, Production and Maintenance		
Question: Under which conditions is it possible to use the device shown on page 2 as a mechanical restraint device?		
Solution: The restraint device shown on page 2 cannot be used as mechanical restraint devices in the sense of 5.2.1.1, 1 st indent, because they act by friction alone. It can be used in combination with a hydraulic restraint device in the sense of clause 5.2.1.1, 3 rd indent, if the function of both restraint devices are monitored (see 5.2.1.4) in such a way that if the hydraulic restraint device fails the possibility to introduce pressure in the upper part is always avoided. The restraint device shown on page 2 can be used alone also as a restraint device in the sense of cl. 5.2.2 of EN 693.		
Adaptation procedure: FORMAL ADAPTATION IN CONFORMITY WITH DIRECTIVE 2006/42/EC		

(1) Essential health and safety requirement

Note: According to point 6.6 of the Guide of the implementation of directives based on the New Approach and the Global Approach, the notified bodies apply as general guidance this recommendation for use

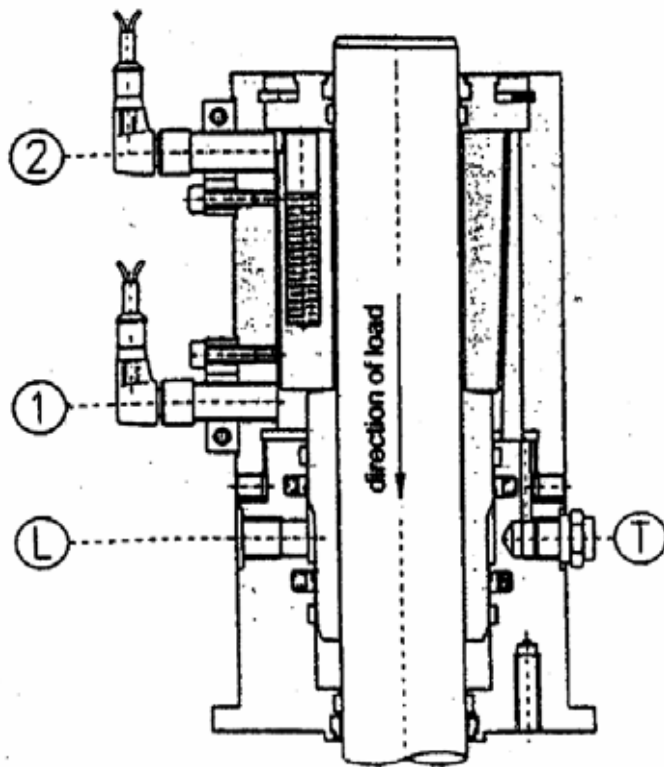



Figure of KR-Type

Legend

- | | | | |
|---------------------|---|---------------------------------------|-------------------|
| Sensors of position | { | 1 | Load secured |
| | | 2 | Clamping released |
| L inlet port | { | to introduce/ evacuate pressure | |
| T outlet port | | with the help of one auxiliary valve. | |

Figure 2

	CO-ORDINATION OF NOTIFIED BODIES Machinery Directive 2006/42/EC + Amendment RECOMMENDATION FOR USE		CNB/M/03.164 Revision 06 Language: E	
Date of first stage: 23/09/2002	To be approved by:		Approved on:	
Origin: VG3 Presses for cold working metals	<input checked="" type="checkbox"/> Vertical Group	29/09/2009	<input checked="" type="checkbox"/> Horizontal Committee.....	16/06/2003
Question related to: Dir. 2006/42/EC Article: Annex: I EHSR (1): 1.2.5	To be endorsed by:		Endorsed on:	
	<input checked="" type="checkbox"/> Machinery Working Group.		17/12/2003	
Question related to: Dir. 2006/42/EC Article:	EN/prEN: EN 12622:2001		Other: prEN 12622:2009	
Annex: I	Normative clause: 5.4.3		Other clause: 5.2.5.11	
	CEN TC concerned: TC 143			
Key words: Press Brakes - Mode selection				
<p>Question:</p> <p>In some cases, press brakes are arranged and programmed to carry out in one cycle successively several operations on the same product.</p> <p>In such cases, the machine can for example have two control stations, that are activated by the program at the right moment and used by the same operator. Under which conditions can we accept such kind of "mode selection" carried out solely by the (normal) programmable control?</p> <p>A variant of the described situation is e.g. the case where at certain moments a single operator is working with the machine, while at other moments there are two operators. Here also there are technical solutions defining through software the active station(s).</p>				
<p>Solution:</p> <p>A normal programmable system by itself is not able to do the selection of the number of operators. The selection of the numbers of operators shall be necessarily hardwired or monitored by a safety PLC. Two cases could be considered:</p> <p>A) In case of one operator using different work stations: Yes, when an AOPD (in the form of light curtain or multi-beam laser system) is active only during the approach; when it is muted, the press brake shall work with hold-to-run control in conjunction with slow speed. The activation of a work station shall be indicated by visual means (e.g. lamp). This visual signal shall be periodically monitored (e.g. by pressing a push button). In the case of a fault in the control system, it shall not be possible to have several work stations active simultaneously.</p> <p>B) In case of several operators using each a different working station: No, in general it is not permitted to work in this way (see clauses. 5.3.19 and 5.4.3.3 of EN 12622:2001); however, when an AOPD (in the form of light curtain) is active during the whole stroke and without interruption of the detection field, it is permissible to work with only one starting device.</p> <p>Adaptation procedure: FORMAL ADAPTATION IN CONFORMITY WITH DIRECTIVE 2006/42/EC</p>				

(1) Essential health and safety requirement

Note: According to point 6.6 of the Guide of the implementation of directives based on the New Approach and the Global Approach, the notified bodies apply as general guidance this recommendation for use.

	CO-ORDINATION OF NOTIFIED BODIES Machinery Directive 2006/42/EC + Amendment RECOMMENDATION FOR USE		CNB/M/03.172 Revision 04 Language: E
Date of first stage: 25/09/2002	To be approved by:		Approved on:
Origin: VG3 Presses for cold working metals	<input checked="" type="checkbox"/> Vertical Group..... <input checked="" type="checkbox"/> Horizontal Committee	29/09/2009 16/06/2003	
Question related to: Dir. 2006/42/EC Article: Annex: I EHSR (1): 1.2.1		EN/prEN: EN 692:2005+A1:2009 Normative clauses: 5.2.1.3, 5.2.3.11 CEN TC concerned: TC 143	Other: Other clause:
Key words: Safety valve, separated clutch and brake			
Question: In a mechanical press with pneumatic clutch and brake separated, is it necessary to use two separate safety valves, one for the control of the clutch and another for the control of the brake or is it possible to use only one safety valve for the control of both?			
Answer: For a mechanical press: 1. To initiate a stroke, it is necessary first to release the brake and then to control the clutch. 2. To stop a movement, it is necessary to release the clutch and then to control the brake. In order to prevent unintended gravity fall, a short time is required for synchronisation particularly in such cases where two valves are used. This can be achieved either by one or two double-bodied safety valves. The manufacturer of the press shall provide means (e.g. bleeds) to avoid overlapping between clutch and brake and, relating to residual pressure, shall take care of the positioning of the valves. This must be achieved according to the technical documentation of the clutch, the brake and the valves. The technical file must contain a clear description of that means, if necessary, with a calculation.			

Adaptation procedure: FORMAL ADAPTATION IN CONFORMITY WITH DIRECTIVE 2006/42/EC

(1) Essential health and safety requirement

Note: According to point 6.6 of the Guide of the implementation of directives based on the New Approach and the Global Approach, the notified bodies apply as general guidance this recommendation for use.

	CO-ORDINATION OF NOTIFIED BODIES Machinery Directive 2006/42/EC + Amendment RECOMMENDATION FOR USE	CNB/M/03.176 Revision 05 Language: E
Date of first stage: 22/09/2003	To be approved by:	Approved on:
Origin: VG3 Presses for cold working metals	<input checked="" type="checkbox"/> Vertical Group..... <input checked="" type="checkbox"/> Horizontal Committee	29/09/2009 09/06/2005
Question related to: Dir. 2006/42/EC Article: Annex: I EHSR (1): 1.2.3	EN/prEN: EN 693:2001 Normative clause: 5.3.15 g); 5.4.1.2 CEN TC concerned:	Other: Other clause:
Key words: RESTART / RESET / AOPD		
<p>Question: If a press is safeguarded by light curtain used for cycle initiation and the pre-set time has passed, may the reset and restart of the press be initiated via a standard PLC?</p>		
<p>Solution: After the pre-set time has passed, the reset of the press can be initiated by a standard PLC after intended initiation by the operator. The first stroke after the reset operation will be restarted by a single or double break action in the detection field of the light curtain. The reset device shall be situated in position giving a good view of the hazardous area.</p> <p>Adaptation procedure: FORMAL ADAPTATION IN CONFORMITY WITH DIRECTIVE 2006/42/EC</p>		

(1) Essential health and safety requirement
Note: According to point 6.6 of the Guide of the implementation of directives based on the New Approach and the Global Approach, the notified bodies apply as general guidance this recommendation for use.

	CO-ORDINATION OF NOTIFIED BODIES Machinery Directive 2006/42/EC + Amendment RECOMMENDATION FOR USE	CNB/M/03.180 Revision 04 Language: E
Date of first stage: 08/06/2004	To be approved by:	Approved on:
Origin: VG3 Presses for cold working metals	<input checked="" type="checkbox"/> Vertical Group..... <input checked="" type="checkbox"/> Horizontal Committee To be endorsed by: <input checked="" type="checkbox"/> Machinery Working Group...	28/09/2009 09/12/2004 Endorsed on: 24/05/2005
Question related to: Dir. 2006/42/EC Article: Annex: I EHSR (1): 1.3.8	EN/prEN: EN 12622:2001 Normative clause: 5.3.24.1 CEN TC concerned: TC 143	Other: Other clause:
Key words: Press-brakes - Ancillary devices - Powered tools clamping devices		
Question: 1. In some cases press brakes are fitted with pneumatic or hydraulic tools clamping devices. Which requirements shall be adopted to prevent fingers being trapped during the locking movement? 2. What measures have to be taken to ensure a secure and correct locking of the tools?		
Solution: 1. To prevent the fingers being trapped during tool setting the manufacturer of the press-brakes shall give clear instructions in the machines manual about the residual risk concerning clamping devices. 2. It has to be ensured, that a loss of pressure does not lead to an insecure tool. This might be achieved by a system consisting of a mechanical tool retention or security system (both preventing the tool from falling down) together with either a) a mechanical forced clamping (e.g. by spring force) pneumatic or hydraulic energy only being used to de-clamp the tool* or b) a positive clamping by use of pneumatic or hydraulic energy together with a pressure sensing device interlocked with a control system of the press-brakes according to category 2 of EN954-1:1996. * Single faults in clamping device shall not lead to loss of the clamping function.		
Adaptation procedure: FORMAL ADAPTATION IN CONFORMITY WITH DIRECTIVE 2006/42/EC		

(1) Essential health and safety requirement

Note: According to point 6.6 of the Guide of the implementation of directives based on the New Approach and the Global Approach, the notified bodies apply as general guidance this recommendation for use.

 <p>EUROPEAN CO-ORDINATION OF NOTIFIED BODIES MACHINERY</p>	<p>CO-ORDINATION OF NOTIFIED BODIES Machinery Directive 2006/42/EC + Amendment</p> <p>RECOMMENDATION FOR USE</p>	<p>CNB/M/03.185 Revision 05 Language: E</p>
<p>Date of first stage: 09/06/2004</p> <p>Origin: VG3 Presses for cold working metals</p>	<p>To be approved by:</p> <p><input checked="" type="checkbox"/> Vertical Group</p> <p><input checked="" type="checkbox"/> Horizontal Committee.....</p> <p>To be endorsed by:</p> <p><input checked="" type="checkbox"/> Machinery Working Group.</p>	<p>Approved on:</p> <p>30/09/2009</p> <p>09/06/2005</p> <p>Endorsed on:</p> <p>29/10/2005</p>
<p>Question related to: Dir. 2006/42/EC Article:</p> <p>Annex: I EHSR (1): 1.4.2; 1.4.2.2</p>	<p>EN/prEN: EN 693:2001, EN 692:2005+A1:2009</p> <p>Normative clause: 5.3</p> <p>CEN TC concerned: TC 143/WG1</p>	<p>Other:</p> <p>Other clause:</p>
<p>Key words: Movable screens</p>		
<p>Question:</p> <p>Q: 1. Which safeguarding is necessary for pneumatically or electrically vertically driven guards on a press when the guard is manoeuvred with ordinary two hand control or when a single hold-to-run pushbutton is used?</p> <p>Q: 2. When is it acceptable to use an impulse button as the control device for movable guard?</p> <p>Q: 3. When must fall arresters (anti-drop safeguards) as described in EN 12604 be used?</p>		
<p>Solution:</p> <p>The manufacturer has to do a risk assessment according to EN 954-1:1996 to define the preferable category for the control system of the movement of the door. During this assessment the manufacturer will have to judge if the kinetic energy of the movement of the guard is big enough to cause serious injury.</p> <p>A:1. When a two hand control or a hold to run pushbutton is used for the guard and the operator has a good view of the area around the door and of the tool area no other safety measures have to be taken. The force (pressure) must be lower than 150 N (50 N/cm²) or additional safeguarding measures have to be implemented in the trapping zone generated by the guards.</p> <p>A: 2. Always if the operator has a good view of the area around the door and of the tool area and it is not possible to enter the danger zone during the closing movement of the guard and if one of the following conditions is fulfilled:</p> <ul style="list-style-type: none"> - the requirements of 5.2.5.2 of EN 953:2009 are fulfilled (e.g. a sensitive edge that reverses the door in case of obstruction is installed) or - there is no danger presented by the guard. <p>A: 3. If one single mechanical fault leads to an unintended gravity fall causing a force exceeding 150 N additional safe guarding measures shall be taken into consideration (e.g. fall arresters, double independent drive systems, over dimensioning of critical parts or other solutions as described in EN 12604).</p> <p>Adaptation procedure: FORMAL ADAPTATION IN CONFORMITY WITH DIRECTIVE 2006/42/EC</p>		

(1) Essential health and safety requirement

Note: According to point 6.6 of the Guide of the implementation of directives based on the New Approach and the Global Approach, the notified bodies apply as general guidance this recommendation for use.

	CO-ORDINATION OF NOTIFIED BODIES Machinery Directive 2006/42/EC + Amendment RECOMMENDATION FOR USE		CNB/M/03.186 Revision 06 Language: E	
Date of first stage: 09/06/2004	To be approved by:		Approved on:	
Origin: VG3 Presses for cold working metals	<input checked="" type="checkbox"/> Vertical Group	28/09/2009	<input checked="" type="checkbox"/> Horizontal Committee.....	26/11/2009
	To be endorsed by:		Endorsed on:	
Question related to: Dir. 2006/42/EC Article: Annex: IV-9 EHSR (1):	EN/prEN: EN692:2005+A1:2009(1), Other: EN 693:2001+A1:2009(2), EN 12622:2001(3), Normative clause: 5.4.4 (1), 5.4.3 Other clause: (2), 5.4.2 (3), CEN TC concerned: TC 143			
Key words: Acceptability of a component, configurable or parameterizable PES				
Question: Should a manufacturer of a press, that relies on the below described PES to manage the safety control functions of the machine have carried out an EC type examination or produce the machine using a full quality assurance system approved by a notified body according to annex X of the Machinery Directive 2006/42/EC or not ?				
Description: According to above mentioned clauses the safety related functions of presses shall not rely solely on a PES. Recently several safety programmable electronic systems (SPES) have appeared on the market referred as configurable safety relay, or parameterizable safety unit, etc. These systems differ from the freely-programmable safety control systems in the following features: The function blocks are already programmed and certified. Programming an application consist of doing the following steps, in a graphical user-interface: a) Choosing the input functions (icon boxes), unfolding input function windows for setting their specific parameters and assigning connection terminals to the input functions b) Doing the same for the output functions c) Calling the linking functions (AND, OR, etc.) and d) Wiring all blocks; The user does not need to develop a complex programme properly, but these systems are also considered to be PES. Some systems are dedicated to an application and the main part of the logic is already programmed, so the manufacturers of the machines only have to properly parameterize (tailor) the system to its own application. Solution: Yes, Manufacturers of annex IV machinery are obligated to follow EC type examination procedure or manufacture using a full quality assurance system as described above as long as these types of safety systems are excluded from above mentioned harmonised standards.				

(1) Essential health and safety requirement

Note: According to point 6.6 of the Guide of the implementation of directives based on the New Approach and the Global Approach, the notified bodies apply as general guidance this recommendation for use.

	CO-ORDINATION OF NOTIFIED BODIES Machinery Directive 2006/42/EC + Amendment RECOMMENDATION FOR USE	CNB/M/03.187 Revision 05 Language: E
Date of first stage: 09/06/2004	To be approved by:	Approved on:
Origin: VG3 Presses for cold working metals	<input checked="" type="checkbox"/> Vertical Group <input checked="" type="checkbox"/> Horizontal Committee..... To be endorsed by: <input checked="" type="checkbox"/> Machinery Working Group.	30/09/2009 09/06/2005 Endorsed on: 29/10/2005
Question related to: Dir. 2006/42/EC Article: Annex: I EHSR (1): 1.2; 1.3.2	EN/prEN: EN 692:2005+A1:2009 Normative clauses: 5.2.6, 5.2.6.4 CEN TC concerned: TC 143	Other: Other clause:
Key words: failure of auxiliary powered functions for setting		
<p>Question:</p> <p>Automatic systems to facilitate the tool setting of presses, such as powered drives for slide and stroke adjustment and for their locking (e.g. clamping devices of the eccentric and the screw) are available on the market. It is intended that they are manually initiated via a deliberate/intended action.</p> <p>EN 692 clause 5.2.6 specifies requirements for interlocks between control circuits of drives and clutches and also to ensure the locking of adjustments during production (5.2.6.4).</p> <p>Therefore:</p> <p>a) Which categories shall control circuits for powered slide adjustment (e.g. control of position of the eccentric and other associated bars) conform to in the case of manual loaded and/or unloaded mechanical presses?</p> <p>b) Which categories shall control circuits for the stroke adjustment (e.g. control of the correct clamping of the screw) conform to</p> <ul style="list-style-type: none"> • in the case of manual loaded and/or unloaded mechanical presses? 		
<p>Answer:</p> <p>Firstly, these functions shall only be available in setting mode:</p> <p>a) The control circuits for locking powered slide adjustment in the correct position for production mode shall at least conform to Category 1. Additionally the position of the clamping devices shall be monitored. This function must be automatically tested at least at each of tool setting.</p> <p>b) The control circuits for locking the powered stroke adjustment in the correct position for production mode shall at least conform to Category 1.</p>		
Adaptation procedure: FORMAL ADAPTATION IN CONFORMITY WITH DIRECTIVE 2006/42/EC		

(1) Essential health and safety requirement

Note: According to point 6.6 of the Guide of the implementation of directives based on the New Approach and the Global Approach, the notified bodies apply as general guidance this recommendation for use.

	CO-ORDINATION OF NOTIFIED BODIES Machinery Directive 2006/42/EC + Amendment RECOMMENDATION FOR USE		CNB/M/03.188 Revision 06 Language: E
Date of first stage: 07/06/2004	To be approved by:		Approved on:
Origin: VG3 Presses for cold working metals	<input checked="" type="checkbox"/> Vertical Group..... <input checked="" type="checkbox"/> Horizontal Committee To be endorsed by: <input checked="" type="checkbox"/> Machinery Working Group...		28/09/2009 10/08/2008 Endorsed on: 08/01/2009
Question related to: Dir. 2006/42/EC Annex: I	Article: EHSR (1): 1.4.2.2	EN/prEN: EN 692: 2005, EN 693 :2001 Normative clause: CEN TC concerned: TC 143	Other: EN 13736:2003 Other clause:
Key words: Front guard switch			
Question: Is only one non mechanical actuated switching unit consisting of one active and one inactive part (e.g. a magnetic switch) acceptable for interlocking a cyclic front guard of a press?			
Solution : Yes, if: <ul style="list-style-type: none"> - The switching unit and the safety logic fulfil category 4 of EN 954-1 (redundant and monitored) and - A cyclic test (at least once per stroke) is done in any operational mode to verify that the moving part of the switching unit is not attached to the other part permanently. A negative test result shall lead to a prevention of further stroke initiation. The cyclic test can be done e.g. by a standard PLC. <p>If a cyclic test can not be done (e.g. when the press can be operated also in automatic mode) the switching unit shall be mounted so that the actuating part of the unit can not be removed for the purpose of disabling the safety system (see EN 1088:1995/prA1:2005). The parts of the switching unit must then be a “unique” pair.</p> <p>“Unique” means that it is unlikely to find another matching part that can be used to defeat the protective system.</p> <p>Adaptation procedure: FORMAL ADAPTATION IN CONFORMITY WITH DIRECTIVE 2006/42/EC</p>			

(1) Essential health and safety requirement

Note: According to point 6.6 of the Guide of the implementation of directives based on the New Approach and the Global Approach, the notified bodies apply as general guidance this recommendation for use.

	<p style="text-align: center;">CO-ORDINATION OF NOTIFIED BODIES Machinery Directive 2006/42/EC + Amendment</p> <p style="text-align: center;">RECOMMENDATION FOR USE</p>		CNB/M/03.189 Revision 05 Language: E
Date of first stage: 31/08/2005	To be approved by:		Approved on:
Origin: VG3 Presses for cold working metals	<input checked="" type="checkbox"/> Vertical Group <input checked="" type="checkbox"/> Horizontal Committee		30/09/2009 21/11/2005
	To be endorsed by: <input checked="" type="checkbox"/> Machinery Working Group.		Endorsed on: 20/04/2006
Question related to: Dir. 2006/42/EC	Article:	EN/prEN: EN 1088:1995 +A2:2008	Other:
Annex: I	EHSR (1): 1.4.1	Normative clause:	Other clause:
		CEN TC concerned:	
Key words: Defeat of protective measures on presses			
<p>Question:</p> <p>Which methods may be used to prevent unauthorized loosening or tampering of screws/settings when the risk of manipulation is high and the manipulation will not be detected by the control system for:</p> <ul style="list-style-type: none"> • Interlock switches and their keys • Non-mechanical interlock switches (e.g. magnetic, proximity switches) • Press table extensions used to prevent standing behind the light curtain considering that these extensions sometimes are damaged and therefore it must be possible to change/repair them <p>Adjustable hydraulic valves/safety valves</p>			
<p>Solution:</p> <p>Answer :</p> <p>Possible methods are those ones where the destruction of the fastener is necessary for disassembling, e.g.:</p> <ul style="list-style-type: none"> • One way screws • Screws with destroyed head e.g. drilled out or epoxy filled allen/torx/Phillips/pozidrive screw • Spot welded screws • Spot welding on the part itself • Riveting • <p>Sealing with lead or similar methods is only acceptable to prevent from unauthorized manipulation of valves</p> <p>The use of “safety screws” which can be loosened with a special tool without destroying them is not considered to be sufficient for fixing a single interlocking switch.</p> <p>See EN 1088:1995/prA1:2004 (ISO/TC 199 WG 7 N0006)</p> <p>Adaptation procedure: FORMAL ADAPTATION IN CONFORMITY WITH DIRECTIVE 2006/42/EC</p>			

(1) Essential Health and Safety Requirement

Note: According to point 6.6 of the Guide of the implementation of directives based on the New Approach and the Global Approach, the notified bodies apply as general guidance this recommendation for use.

	CO-ORDINATION OF NOTIFIED BODIES Machinery Directive 2006/42/EC + Amendment RECOMMENDATION FOR USE	CNB/M/03.192 Revision 04 Language: EN
---	---	---

Date of first stage: 21/03/2006	To be approved by:	Approved on:
Origin: VG3 Presses for cold working metals	<input checked="" type="checkbox"/> Vertical Group..... <input checked="" type="checkbox"/> Horizontal Committee To be endorsed by: <input checked="" type="checkbox"/> Machinery Working Group.	06/10/2008 09/12/2008 Endorsed on: 18/06/2009
Question related to: Dir. 2006/42/EC Article: Annex: 1 EHSR (1):	EN/prEN: EN 12622:2001 Normative clause: CEN TC concerned: TC 143	Other: pr EN 12622:2007 Other clause :

Key words: Press brakes – secondary working devices

Question:

Some press brakes are equipped with secondary devices (e.g. bend and push devices) which don't stand in the bending zone but can use the down stroke movement to perform the operation. This equipment is usually pneumatic with at least two single effect cylinders. What should the safety devices of this secondary working part be?

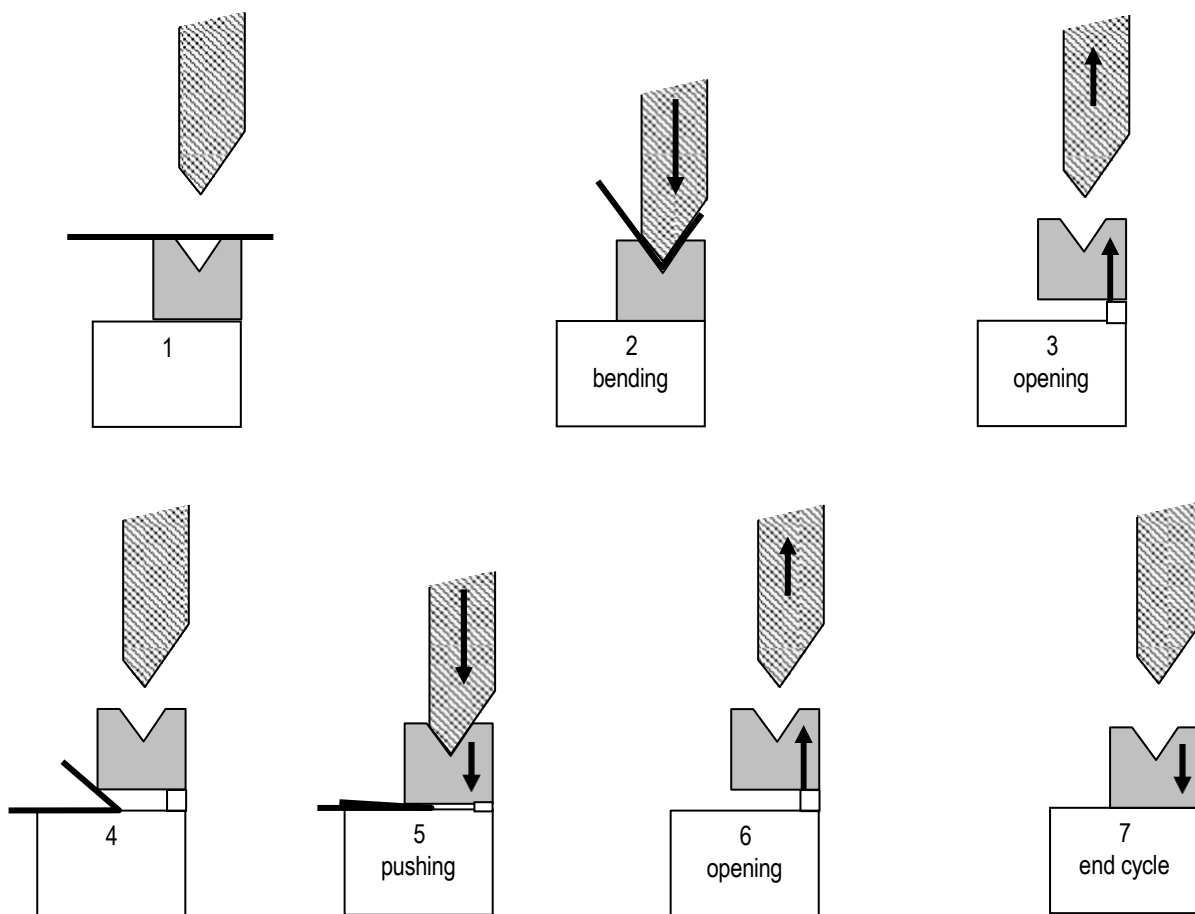

Solution:

This type of tool has two danger zones. The first danger zone (a) is between the main tool and secondary tool and the second danger zone (b) is underneath the secondary tool.

- (a) The closing movement of the main tool should be protected with suitable safeguards.
The relationship of the movements between the main and the secondary tool need to be protected to prevent crushing between the main and the secondary tool in normal operation and due to unintended opening of the secondary tool
- (b) If the gap within the secondary tool is less or equal to 6mm the closing movement is not considered to be dangerous.
If the gap within the secondary tool is greater than 6mm a crushing hazard exists therefore the closing movement should be protected with suitable safeguards.

Suitable safeguards to address (a) and (b) above could be:

- Light curtains of type 4 according to EN 61496-1 which stop the closing movement of the beam and any movement of the secondary tool as soon they are interrupted in combination with monitoring and inbuilt redundancy of the drive of the secondary tool (see also EN 13736 pneumatic presses).

or

- A hold-to-run control device in conjunction with a maximum speed of 10mm/s (safe or monitored by a system of cat. 3 acc. to EN 954-1 or PL_D acc. to EN 13849-1) of the secondary tool for the initiation of the closing and opening movement of the secondary tool when used in combination with interlocking which prohibits any upward movement of the secondary tool as long as the main tool is in down stroke mode.

or

- A hold-to-run control device in conjunction with a maximum speed of 10mm/s (safe or monitored by a system of cat. 3 acc. to EN 954-1 or PL_D acc. to EN 13849-1) of the secondary tool for the initiation of the closing movement of the secondary tool when used in combination with
 - synchronisation (of cat. 3 acc. to EN 954-1 or PL_D acc. to EN 13849-1) between the upward movement of the main and the secondary tool in a manner that ensures that the speed of the main tool is always higher than the speed of the secondary tool so that the gap between the tools is always increasing during this movement

or

- a system of category 3 according to EN 954-1 or PL_D according to EN 13849-1 preventing the opening of the secondary tool as long as the beam has not reached a minimum distance from the secondary tool of 100 mm plus the stroke of the secondary tool.

Adaptation procedure: FORMAL ADAPTATION IN CONFORMITY WITH DIRECTIVE 2006/42/EC

(1) Essential health and safety requirement

Note: According to point 6.6 of the Guide of the implementation of directives based on the New Approach and the Global Approach, the notified bodies apply as general guidance this recommendation for use.

	CO-ORDINATION OF NOTIFIED BODIES Machinery Directive 2006/42/EC as amended RECOMMENDATION FOR USE		CNB/M/03.193 Revision : 06 Language : EN
Number of pages : 1	Date : 20.03.2006	To be approved by :	Approved on :
Origin : VG3 Presses for the cold working of metals		<input checked="" type="checkbox"/> Vertical Group <input checked="" type="checkbox"/> Horizontal Committee To be endorsed by : <input type="checkbox"/> Machinery Working Group 03.03.2009 10.06.2009 Endorsed on : 31.01.2018
Question related to : Dir. 2006/42/EC	Article : -	EN/prEN : no applicable standard	Other : EN 692:2005, EN 693:2001, EN 12622:2001
Annex : I	EHSR (1) : 1.2.1	Normative clause : -	Other clause : -
CEN TC concerned : -			
Key words: Servo Press (Power Presses & Press Brakes), Muting, Slow Speed / Directional Monitoring			
Question:			
How is it possible to mute the safeguarding devices of a servo press where the stopping time is relevant?			
Recommended solution:			
a) Mute during opening movement			
<p>The muting of the safeguarding device during opening movement shall be in accordance with EN ISO 13849-1:2008 category 4 PL e. The direction monitoring shall be in accordance with EN ISO 13849-1:2008 PL d.</p> <p>In case of failure, the maximum movement of the beam in the closing direction shall be limited to a reasonable value (good experiences have been made with a value not exceeding 6 mm).</p>			
b) Mute during slow speed in conjunction with hold to run control			
Slow closing speed less than or equal to 10 mm/s that allows the muting of the safeguarding device shall be:			
<ul style="list-style-type: none"> - limited by fixed means (e.g. use of a clutch), or - monitored according to EN ISO 13849-1:2008 PL d. The over-speed detection shall have an adequately short response time. In case of over-speed detection a STO shall be applied and the braking mechanism shall be activated. 			
The release of the hold to run control (e.g. foot pedal) shall lead to a Safe Stop 1.			

Note : According to point 6.6 of the Guide of the implementation of directives based on the New Approach and the Global Approach, the notified bodies apply as general guidance this recommendation for use.

Sent for information to: members of the VG other(s) VG HC (2) TC (3) SC (4) other (5)

(1) Essential Health and Safety Requirement

(3) N° of CEN/TC (Secretary & Chairman)

(5) To be specified

(2) Horizontal Committee

(4) Machinery Working Group

	CO-ORDINATION OF NOTIFIED BODIES Machinery Directive 2006/42/EC + Amendment RECOMMENDATION FOR USE	CNB/M/03.194 Revision 05 Language: E
Date of first stage: 03/03/2008	To be approved by:	Approved on:
Origin: VG3 Presses for cold working of metals	<input checked="" type="checkbox"/> Vertical Group	03/03/2009
	<input checked="" type="checkbox"/> Horizontal Committee	10/06/2009
Question related to: Directive 2006/42/EC Article: Annex: I ESR (1): 1.2.6	EN/prEN: EN 692:2005, EN 693:2001, EN 12622:2001	Other:
	Clause:	Other clause:
	CEN TC concerned:	
Key words: Servo press (Power Presses & Press Brakes), brake		
Question: What kind of brake system could be used on a mechanical press without a clutch, driven by a servo-drive system?		
Solution: If the servo controller provides a safe torque off function (STO) according to ISO 13849-1:2006 category 4 PL e, a stop category 1 acc. to EN 60204-1:2007 and a stopping performance monitoring according to ISO 13849-1:2006 PL d the following solutions may be acceptable: External mechanical brakes shall be used. They shall be mechanically and positively linked to the ram. If no mechanical and positive link is realised equivalent measures shall be taken. Circuits driving the brake systems shall be designed and monitored according to the needs of the safety control system. a) If the stopping time is relevant (depending on the safeguarding system e.g. non physical barrier) fail safe brake systems (e.g. a single brake as specified in EN 692 or equivalent) shall be used and a test of the brake performance has to be done to show the sufficient friction of the brake. If this test is done in a stand still position, it must be shown that also the stopping time under worst case conditions will be guaranteed. The interpretation of the test result must be done by the safety control system. The test has to be done at each power on, at each change of operational mode and at least after one hour of operation in single stroke mode or after eight hours of operation in automatic mode. The relevant sections of Annex B.4 of EN 692:2005 shall be taken into consideration for the design and testing of the brake. b) If the stopping time is not relevant a spring operated park brake system alone may be enough. In any case the stand still of the ram shall be monitored. The braking torque of external mechanical brakes preventing descent of the load (normally the ram) shall be reasonably overdimensioned (recommended value 1,25) with respect to the total mass of the ram including fitted tooling. Note: STO is defined in IEC 61800-5-2:2007		

(1) Essential safety requirement

Note: According to point 6.6 of the Guide of the implementation of directives based on the New Approach and the Global Approach, the notified bodies apply as general guidance this recommendation for use.

	CO-ORDINATION OF NOTIFIED BODIES Machinery Directive 2006/42/EC + Amendment RECOMMENDATION FOR USE	CNB/M/03.196 Revision 04 Language: E	
Date of first stage: 07/10/2008		To be approved by:	Approved on:
Origin: VG3 Presses for the cold working of metals		<input checked="" type="checkbox"/> Vertical Group..... <input checked="" type="checkbox"/> Horizontal Committee	07/10/2008 09/12/2008
		To be endorsed by :	Endorsed on :
		<input checked="" type="checkbox"/> Machinery Working Group	18/06/2009
Question related to: Dir. 2006/42/EC	Article:	EN/prEN:	Other:
Annex: 1	EHSR (1):	Normative clause:	Other clause :
		CEN TC concerned: TC 143	
Key words: Servo presses, protective measures			
Question: What kind of protective measures are acceptable for servo presses?			
Solution: It is recognised that servo-presses have similar features to both mechanical and hydraulic presses. Therefore the protective measures as described in EN 692, EN 693 or EN 12622 are found acceptable on servo presses. The level of safety shall not be lower than the one in the indicated standards.			
Adaptation procedure: FORMAL ADAPTATION IN CONFORMITY WITH DIRECTIVE 2006/42/EC			

(1) Essential health and safety requirement

Note: According to point 6.6 of the Guide of the implementation of directives based on the New Approach and the Global Approach, the notified bodies apply as general guidance this recommendation for use.

	CO-ORDINATION OF NOTIFIED BODIES Machinery Directive 2006/42/EC + Amendment RECOMMENDATION FOR USE	CNB/M/03.200 Revision 05 Language: E
Date of first stage: 25/09/2008	To be approved by:	Approved on:
Origin: VG3 Presses for the cold working of metals	<input checked="" type="checkbox"/> Vertical Group <input checked="" type="checkbox"/> Horizontal Committee To be endorsed by: <input checked="" type="checkbox"/> Machinery Working Group....	03/03/2009 10/06/2009 Endorsed on: 25/12/2009
Question related to: Directive 2006/42/EC Article: Annex: I ESR (1): 1.2.4	EN/prEN: EN 692:2005, EN 693:2001, EN 12622:2001 Clause: CEN TC concerned:	Other: Other clause:
Key words: Servo-presses (Power Presses & Press Brakes), Stopping performance monitoring		
Question: Stopping performance monitoring on servo - presses Which solution is acceptable?		
Solution: Where the response time (stopping performance) of a servo-press is safety-relevant, the response time has to be determined taking into account all errors concerning safety. If it is not possible for the press's safety control system to detect certain faults at least at the following check, the (additional) occurrence of further faults must be assumed. The effect of any assumable fault on the response time of the stopping function has to be taken into account for the calculation of the safety distance.		

(1) Essential safety requirement

Note: According to point 6.6 of the Guide of the implementation of directives based on the New Approach and the Global Approach, the notified bodies apply as general guidance this recommendation for use.

	CO-ORDINATION OF NOTIFIED BODIES Machinery Directive 2006/42/EC + Amendment RECOMMENDATION FOR USE	CNB/M/03.201 Revision 05 Language: E
Date of first stage: 25/09/2008	To be approved by:	
Origin: VG3 Presses for the cold working of metals	Approved on: <input checked="" type="checkbox"/> Vertical Group 04/03/2009 <input checked="" type="checkbox"/> Horizontal Committee 10/06/2009	
	To be endorsed by: <input checked="" type="checkbox"/> Machinery Working Group.... 25/12/2009	
Question related to: Directive 2006/42/EC Article: Annex: I ESR (1): 1.2.1, 1.2.3	EN/prEN: EN 692:2005, EN 693:2001, EN 12622:2001 Clause: CEN TC concerned:	Other: Other clause:
Key words: Servo-presses (Power Presses & Press Brakes), STO, prevention of unintended start		
Question: Which category / performance level is necessary for the safe torque off (STO) function of each drive of a press slide driven by more than one servo drive?		
Solution: The current power press standards as well as the press brake standard require category 4 of EN 954-1:1996 for the overall stopping performance of the slide. This general requirement is also valid for servo presses. With respect to the new standard EN ISO 13849-1:2008 the corresponding requirement is PL e and category 4. Where the unexpected start of one of the drives cannot lead to significant slide movement (e.g. not more than 6 mm) because the slide is blocked due to the mechanical construction of the press the category and performance level of the STO of each drive may be of the next lower level compared to the level required for a press with a single servo drive as long as the performance level stays equal to or above d.		

(1) Essential safety requirement

Note: According to point 6.6 of the Guide of the implementation of directives based on the New Approach and the Global Approach, the notified bodies apply as general guidance this recommendation for use.

	CO-ORDINATION OF NOTIFIED BODIES Machinery Directive 2006/42/EC + Amendment RECOMMENDATION FOR USE		CNB/M/03.202 Revision 04 Language: E
Date of first stage: 03/03/2009	To be approved by:		Approved on:
Origin: VG3 Presses for the cold working of metals	<input checked="" type="checkbox"/> Vertical Group <input checked="" type="checkbox"/> Horizontal Committee To be endorsed by: <input checked="" type="checkbox"/> Machinery Working Group....		03/03/2009 10/06/2009 Endorsed on: 25/12/2009
Question related to: Directive 2006/42/EC Article: Annex: I ESR (1): 1.3.7	EN/prEN: EN 12622:2009 Clause: 5.3.21 CEN TC concerned: TC 143		Other: Other clause:
Key words: Press brakes – back gauge movement initiation			
Question: Which alternative protective measures besides those described in clause 5.3.21 of EN 12622:2009 are acceptable to protect operators against hazardous movements of back gauges?			
Solution: It is also acceptable to protect the operator against the hazards arising from the movement of automatically operated back gauges by light curtains (e.g. the light curtain which also protects against access to the press from the front). If none of the features “movement initiation by the operator” or “demarcation of a zone with reduced speed / limited force” or “protection by light curtain” is active for protection against movement of the back gauges, no movement of the back gauges shall be possible.			

(1) Essential safety requirement

Note: According to point 6.6 of the Guide of the implementation of directives based on the New Approach and the Global Approach, the notified bodies apply as general guidance this recommendation for use.

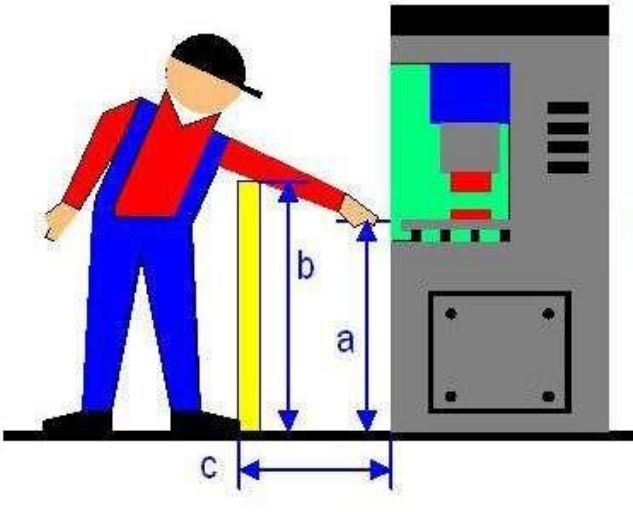
	<p>CO-ORDINATION OF NOTIFIED BODIES Machinery Directive 2006/42/EC + Amendment RECOMMENDATION FOR USE</p>	<p>CNB/M/03.204 Revision 03 Language: E</p>
<p>Date of first stage: 28/09/2011</p>	<p>To be approved by:</p>	<p>Approved on:</p>
<p>Origin: VG3 Presses for cold working metals</p>	<p><input checked="" type="checkbox"/> Vertical Group <input checked="" type="checkbox"/> Horizontal Committee</p> <p>To be endorsed by: <input checked="" type="checkbox"/> Machinery Working Group....</p>	<p>28/09/2011 11/12/2012 Endorsed on: 04/06/2013</p>
<p>Question related to: Directive 2006/42/EC Article: Annex: ESR (1): 1.4.2., 1.4.3.</p>	<p>EN/prEN: EN 692 :2005+A1:2009, EN 693 :2001+A2:2011 Clause: 5.3.2 CEN TC concerned: TC 143 and ISO TC 39/SC 10</p>	<p>Other: EN ISO 13857:2008, 13855:2010 Other clause:</p>
<p>Key words: Presses – Safety distances</p>		
<p>Question: Where a movable or a fixed guard is used to prevent the access to the tools area of presses the Table 1 or 2 of EN ISO 13857:2008 standard shall be checked to verify that it is impossible reaching over the protective structure. In the same way if a light curtain is installed the EN ISO 13855:2010 table 1 shall be verified. To do this it is necessary to fix the height of the hazard zone that is the closing area between the fixed half tool and the movable half tool. How it is possible to identify this hazard zone when the height of the two separate mould halves is unknown?</p>		
<p>Solution: In principle it is impossible to define a minimum or a maximum height of the tools. The dimension of the hazard zone is basically defined by value "a" as determined during the examination considering any possible situation from the maximum opening of the ram to the height of the table. "c" and "b" must be determined according to EN ISO 13857 and EN ISO 13855 considering: - the stopping time and - either the maximum size of the table/ram or the maximum size of the tool whichever is larger. Maximum ram opening position ↘</p>		
		
<p>"a", "b" and "c" are those defined in the corresponding standard (EN ISO 13857 or EN ISO 13855) depending of the safety device</p>		





(1) Essential safety requirement

Note: According to point 6.6 of the Guide of the implementation of directives based on the New Approach and the Global Approach, the notified bodies apply as general guidance this recommendation for use.

	CO-ORDINATION OF NOTIFIED BODIES Machinery Directive 2006/42/EC + Amendment RECOMMENDATION FOR USE	CNB/M/03.206 Revision 03 Language: E
Date of first stage: 27/09/2012	To be approved by:	Approved on:
Origin: VG3 Presses for cold working metals	<input checked="" type="checkbox"/> Vertical Group	27/09/2012
	<input checked="" type="checkbox"/> Horizontal Committee	11/12/2012
Question related to: Directive 2006/42/EC Article: Annex: I ESR (1): 1.4.3.	EN/prEN: EN 692 :2005+A1:2009 Clause: 5.3.2. CEN TC concerned: TC 143	Other: EN 693: 2001+A2:2011 Other clause:5.3.16
Key words: Presses – Two hand control device (THCD)		
Question: Can the THCD be used as the solely protection device for a press at the operator side?		
Solution: According to EN 692:2005+A1:2009 clause 5.3.2. the manufacturer shall select the safeguard method which reduces the risks as far as possible, considering the significant hazards and the method of protection. The operator(s) must have the possibility to overview all the dangerous area at any time (considering the presence of tools and material). It is recommended that if the horizontal access is more than 650 mm [ref EN 693:2001+A2:2011 clause 5.3.16] other safeguarding devices than THCD according to the risk assessment for the particular press should be provided to protect a third person.		

(1) Essential safety requirement

Note: According to point 6.6 of the Guide of the implementation of directives based on the New Approach and the Global Approach, the notified bodies apply as general guidance this recommendation for use.

	<p>CO-ORDINATION OF NOTIFIED BODIES Machinery Directive 2006/42/EC + Amendment RECOMMENDATION FOR USE</p>	<p>CNB/M/03.207 Revision 03 Language: E</p>
<p>Date of first stage: 27/09/2012</p> <p>Origin: VG3 Presses for cold working metals</p>	<p>To be approved by:</p> <p><input checked="" type="checkbox"/> Vertical Group</p> <p><input checked="" type="checkbox"/> Horizontal Committee</p> <p>To be endorsed by:</p> <p><input checked="" type="checkbox"/> Machinery Working Group....</p>	<p>Approved on:</p> <p>27/09/2012 11/12/2012</p> <p>Endorsed on: 04/06/2013</p>
<p>Question related to: Directive 2006/42/EC Article:</p> <p>Annex: I ESR (1): 1.3.7.</p>	<p>EN/prEN: EN 12622: 2009</p> <p>Clause: 5.2.5.6.</p> <p>CEN TC concerned: TC 143</p>	<p>Other: EN 13849-1:2008</p> <p>Other clause:</p>
<p>Key words: Press-brakes – Powered work-piece supports</p>		
<p>Question:</p> <p>EN 12622: 2009 clause 5.2.5.6 c) requires that the unexpected start-up for powered work-piece supports shall be prevented when a hold-to-run control is used.</p> <p>How can be implemented in the control circuit?</p>		
<p>Solution:</p> <p>The control circuit of the hold-to-run control shall conform at least PLr=b EN 13849-1:2008.</p> <p>Explanation: according to EN 13849-1:2008:</p> <ul style="list-style-type: none">  S=1 due to reversible injury,  F=2 due to permanent work place,  P=1 due to sufficient space around and below the work-piece support. 		

(1) Essential safety requirement

Note: According to point 6.6 of the Guide of the implementation of directives based on the New Approach and the Global Approach, the notified bodies apply as general guidance this recommendation for use.

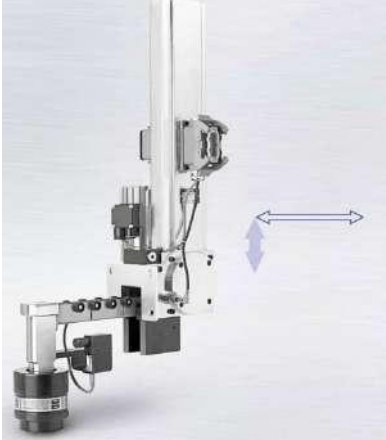
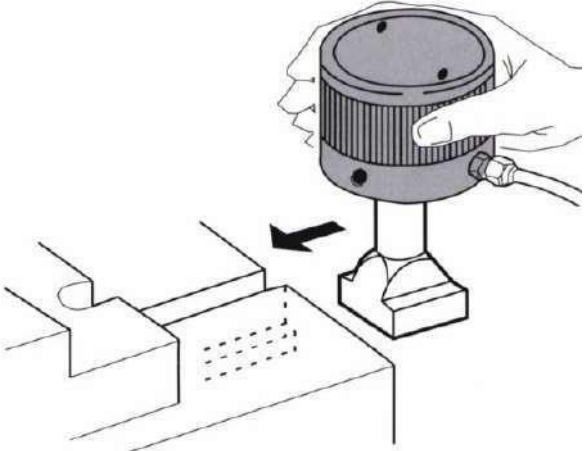
	CO-ORDINATION OF NOTIFIED BODIES Machinery Directive 2006/42/EC + Amendment RECOMMENDATION FOR USE	CNB/M/03.209 Revision 03 Language: E
Date of first stage: 26/09/2013 Origin: VG3 Presses for cold working metals	To be approved by: <input checked="" type="checkbox"/> Vertical Group <input checked="" type="checkbox"/> Horizontal Committee To be endorsed by: <input checked="" type="checkbox"/> Machinery Working Group....	Approved on: 26/09/2013 10/12/2013 Endorsed on: 31/01/2018
Question related to: Directive 2006/42/EC Article: Annex: I ESR (1): 1.3.7	EN/prEN: EN 692:2005 +A1:2009; EN 693:2001 +A2:2011 Clause: 5.3.19.2 CEN TC concerned: TC 143	Other: EN ISO 13857:2008; 13849-1:2008; 12100:2010 Other clause:
Key words: Hydraulically actuated clamps		
<p>Question:</p> <p>What is the performance level for the SRP-CS of closing / opening command of hydraulically clamping devices when:</p> <p>Clamps are integrated in the slide (see fig. 1)</p> <p>Clamps are manually positioned (see fig. 2)</p> <div style="display: flex; justify-content: space-around;">   </div>		
<p>Solution:</p> <p>If the clamping stroke is higher than 6mm (EN ISO 13857:2008)</p> <p>PLr=c for both conditions</p> <p>EXPLANATION</p> <p>Following EN ISO 12100:2010 and EN ISO 13849-1:2008</p> <p>S=2 due to the severity of injury</p> <p>F=1 due to the low frequency of the operation and the short duration of the operation</p> <p>P=1 due to marking of residual risk and qualification of the operators</p> <p>Residual risk of the operation can be reduced by additional measures like keeping safety devices (e.g. Light curtain) active during operation.</p>		

(1) Essential safety requirement
 Note: According to point 6.6 of the Guide of the implementation of directives based on the New Approach and the Global Approach, the notified bodies apply as general guidance this recommendation for use.

Solution:

If the clamping stroke is higher than 6mm (EN ISO 13857 – 2008)
PLr=c for both conditions

EXPLANATION

Following EN ISO 12100 (2010) and EN ISO 13849-1 (2008)

S=2 due to the severity of injury

F=1 due to the low frequency of the operation and the short duration of the operation

P=1 due to marking of residual risk and qualification of the operators

Residual risk of the operation can be reduced by additional measures like keeping safety devices (eg. Light curtain) active during operation

NOTE: This technical sheet regards only the risk of a person being injured for an uncontrolled movement of the clamping devices during the clamping and unclamping operation.

The clamping movement is considered only perpendicular and/or parallel to the tools plane (as shown in the previous figures).

The risk of failure of the clamping device during slide movement is already covered by EN 692:2005+A1 (2009) / EN 693:2001+A2 (2011) clause 5.3.19.2

	CO-ORDINATION OF NOTIFIED BODIES Machinery Directive 2006/42/EC + Amendment		CNB/M/03.210 Revision 04
Date of first stage: 25/09/2014	To be approved by:		Approved on:
Origin: N.B. 0404	<input checked="" type="checkbox"/> Vertical Group <input checked="" type="checkbox"/> Horizontal Committee To be endorsed by: <input checked="" type="checkbox"/> Machinery Working Group....		24/09/2015 02/12/2015 23/09/2016
Question related to: Directive 2006/42/EC Annex: I	Article: ESR (1): 1.3.2	EN/prEN: EN 692:2005+A1:2009 Clause: 5.2.1.4 CEN TC concerned:	Other: EN Other clause: 5.4.1.1
Key words: servo press / press brake – belt connection between motor and screw			
Question: How can the level of safety be kept on a servo press / press brake if the mechanical brake is placed on the servo motor shaft instead of the lead screw which is connected to the motor with a tooth belt			
Solution: See also CNB/M/03.194rev5 Two belts are needed, both monitored PL "d" (EN ISO 13849-1:2008) for breakage. One belt alone must be able to stop the ram (i.e. be able to transmit the nominal braking force) At least 8 consecutive teeth of each belt must be engaged in the pulley. Mechanical parts of shaft, pulleys, screws and their form fit connections shall be dimensioned according to well proven concepts. NOTE: for technical reasons a fault exclusion can be made for the loss of more than 4 teeth in consecutive raw The annual inspection of the machine would show any premature wear; annual inspection shall be stated in the user manual			

(1) Essential safety requirement

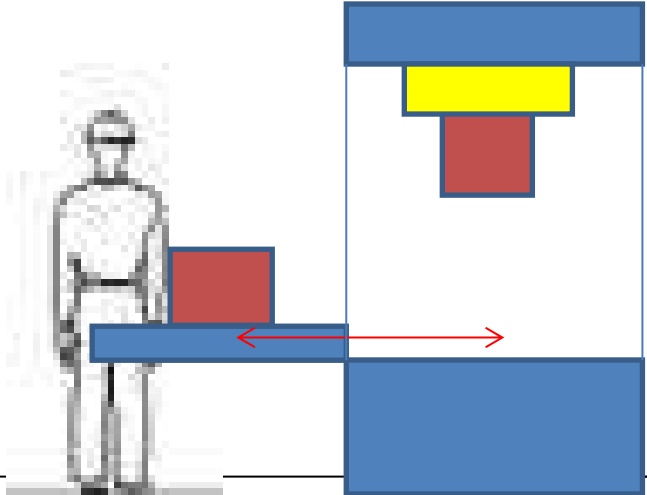
	CO-ORDINATION OF NOTIFIED BODIES Machinery Directive 2006/42/EC + Amendment		CNB/M/03.211 Revision 02
Date of first stage: 25/09/2014	To be approved by:	Approved on:	
Origin: N.B. 0026	<input checked="" type="checkbox"/> Vertical Group	26/09/2014	
	<input checked="" type="checkbox"/> Horizontal Committee.....	24/06/2015	
	<input checked="" type="checkbox"/> To be endorsed by: Machinery Working Group....	23/09/2016	
Question related to: Directive 2006/42/EC Annex: IV	Article: ESR (1):	EN/prEN: Clause: CEN TC concerned:	Other: Other clause:
Key words: presses – Manual loading/unloading work pieces in presses			
<p>Question:</p> <p>The work piece is manually placed on the lower die, which has been slid outside of the danger zone. When the work cycle starts the lower die first slides inside the danger zone and when in position the upper die moves downwards</p> <p>Are these machines included in annex IV?</p> 			
<p>Solution:</p> <p>NO: if the slide is an integrated auxiliary device of the press (the operator can only place the work piece outside the danger zone)</p> <p>YES: if the cycle gives the operator the possibility to place the work piece between the dies (e.g. two steps cycle)</p> <p>See also CNB/M/03.002 rev 15</p>			

(1) Essential safety requirement

F.1 Principle of interlocking corresponding to type III, using electromechanical components

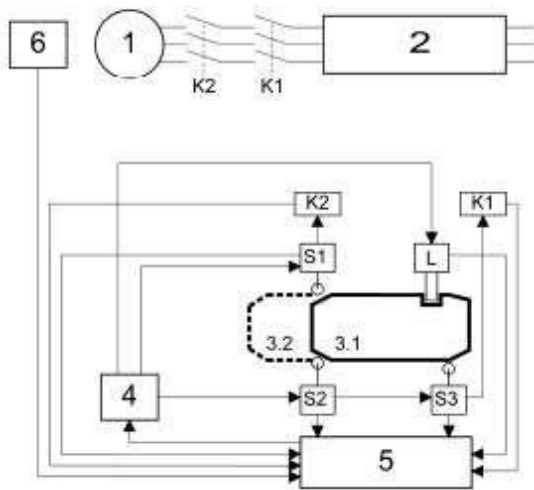

	CO-ORDINATION OF NOTIFIED BODIES Machinery Directive 2006/42/EC + amendments RECOMMENDATION FOR USE		CNB/M/03.214 Revision: 04 Language: EN
Number of pages: 1	Date: 03.07.2023	To be approved by:	Approved on:
Origin: VG3 Presses for cold working metals		<input checked="" type="checkbox"/> Vertical Group	12.09.2019
		<input checked="" type="checkbox"/> Horizontal Committee	14.06.2022
		To be endorsed by:	Endorsed on:
		<input checked="" type="checkbox"/> Machinery Expert Group	23.03.2023
Question related to: Directive 2006/42/EC	Article: -	EN/prEN: EN 12622:2009 + A1:2013	Other: EN 60204-1:2018 EN 62745:2017
Annex: I	EHSR (1): 1.2.1	Normative clause: -	Other clause: -
Key words: Press brake / Control panel / Wireless			
Question: How it is possible to use a wireless station with safety functions to control press brake movements?			
Solution: The following shall be adopted. 1. Performance level according to EN ISO 13849-1:2015 Table 2 of EN 12622:2009 + A1:2013 shall be applied for the safety level of the various safety functions related to the use of the wireless control station (e.g. Hold to run control, Emergency stop, Reset, etc.). 2. Standard requirements Wireless command shall be compliant with: - clause 9.2.4 of EN 60204-1: 2018; - EN 62745: 2017. 3. Loss of communication The loss of communication shall arrest the machine. In this situation safeguard actions through the remote station could not be operative (e.g. the opening of the press). For this reason, it shall be possible to perform these actions on a control panel fixed to the machine. 4. Response time The response time of the wireless communication shall be evaluated in relation to different safety functions. 5. Range of control The press manufacturer shall define the areas where the wireless control station can be used in a safe way. The NB shall check that from these areas there is complete visibility of the dangerous zones.			

(1) Essential health and safety requirement

Note: According to point 6.6 of the Guide of the implementation of directives based on the New Approach and the Global Approach, the notified bodies apply as general guidance this recommendation for use.

	CO-ORDINATION OF NOTIFIED BODIES Machinery Directive 2006/42/EC RECOMMENDATION FOR USE		CNB/M/03.216 Revision: 04 Language: EN
Number of pages: 1	Date: 03.07.2023	To be approved by:	Approved on:
Origin: VG3 Presses for cold working metals		<input checked="" type="checkbox"/> Vertical Group <input checked="" type="checkbox"/> Horizontal Committee To be endorsed by: <input checked="" type="checkbox"/> Machinery Expert Group	24.05.2022 14.06.2022 Endorsed on: 23.03.2023
Question related to: Directive 2006/42/EC	Article: - Annex: I EHSR (1): 1.3.7	EN/prEN: EN ISO 16092-2:2020 Normative clause: 5.2.5.3 CEN TC concerned: TC 143 and ISO TC 39/SC 10	Other: - Other clause: -
Key words: presses with a servo drive system (mechanical servo presses); brakes.			
<p>Question:</p> <p>Several types of brakes are present on the market. For some of them fault exclusion is not possible due, for example, to a specific use on servo-presses. In this case a single fault may lead to a delay of the braking function.</p> <p>Which kind of measures are considered to be applicable and sufficient to detect such fault?</p>			
<p>Solution:</p> <p>Some brakes can be strongly influenced by the specific application. Brakes on servo-presses are subject to other physical influences than conventional mechanical presses; e.g. acceleration values of 1-2 g were measured on drives of mechanical presses, and values up to 16 g on servo-press drives.</p> <p>The following possible solution may be acceptable.</p> <p>In order to allow direct monitoring of those servo-brake components that are moved during switching, these brakes must be equipped with sensors for position-monitoring of components moving during switching, or must be prepared for being equipped with such sensors.</p> <p>During each single cycle an automatic monitoring of the time for the brake activation shall be measured.</p> <p>The time between the activation of the brake (e.g. the switch-off of the electro-valves) and the close position of the brake itself shall be measured and evaluated.</p> <p>If the brake activation time is out of the defined limits the safety control system shall stop the press.</p> <p>The control circuit for the brake monitoring shall have the same Performance Level like the control system/function according to Tables 1 and 2 of the EN ISO 16092-2.</p>			

(1) Essential health and safety requirement

Note: According to point 6.6 of the Guide of the implementation of directives based on the New Approach and the Global Approach, the notified bodies apply as general guidance this recommendation for use.

	CO-ORDINATION OF NOTIFIED BODIES Machinery Directive 2006/42/EC + amendments RECOMMENDATION FOR USE		CNB/M/03.217 Revision: 02 Language: EN
	Number of pages: 1	Date: 03.07.2023	To be approved by: <input checked="" type="checkbox"/> Vertical Group <input checked="" type="checkbox"/> Horizontal Committee To be endorsed by: <input checked="" type="checkbox"/> Machinery Expert Group
Origin: VG3 Presses for cold working metals		EN/prEN: EN ISO 16092-1:2018 Normative clause: 5.4.1.1.3 CEN TC concerned: TC 143 and ISO TC 39/SC 10	Other: - Other clause: -
Question related to: Directive 2006/42/EC	Article: -	Key words: Reset function	
Annex: I	EHSR (1): 1.2.2	Question: Is it allowed to have more than one reset control device for each protection device (interlocked guard or AOPD) of the protected area?	
Solution: Yes, as long as the risk assessment leads to a conclusion of a clear view of the protected area (it would be helpful to save time for the operator, considering also ergonomic aspects). Remark: Clause 5.4.1.1.3 of EN ISO 16092-1 is related to interlocking guards and ESPE using AOPD. The following two sentences in this clause are related to AOPDs only: <i>“There shall not be more than one reset control device for each detection zone. If the press is safeguarded by means of side and back AOPDs, a reset control device shall be provided on each detection zone”</i> .			

(1) Essential health and safety requirement

Note: According to point 6.6 of the Guide of the implementation of directives based on the New Approach and the Global Approach, the notified bodies apply as general guidance this recommendation for use

	CO-ORDINATION OF NOTIFIED BODIES Machinery Directive 2006/42/EC + amendments RECOMMENDATION FOR USE		CNB/M/04.009 Revision: 12 Language: EN
Number of pages: 1 Origin: Injection or compression moulding machines	Date: 31.07.2023	To be approved by: <input checked="" type="checkbox"/> Vertical Group <input checked="" type="checkbox"/> Horizontal Committee To be endorsed by: <input checked="" type="checkbox"/> Machinery Expert Group	Approved on: 03.05.2023 31.05.2023 Endorsed on: 12.04.2024
Question related to: Directive 2006/42/EC Annex: IV	Article: 12 EHSR (1): -	EN/prEN: EN ISO 20430:2020 EN 289:2014 Normative clause: - CEN TC concerned: -	Other: - Other clause: -
Key words: Moulding machinery / automatic loading and unloading			
<p>Question:</p> <p>What are the conditions under which loading and unloading of an injection or compression moulding machine can be considered as manual?</p> <p>Definition according to Guide Ed 2.2 (2019) §388 Loading and unloading is not considered as manual if:</p> <ul style="list-style-type: none"> - the machinery is designed to operate only with robot or manipulator equipment, or - the machinery is fitted with loading and unloading devices such that it is not possible to operate the machinery without those devices. <p>In all other cases, loading and unloading shall be considered as manual.</p>			
<p>Solution:</p> <p>Additional explanations:</p> <p>First dash: the injection or compression moulding machine shall not have a semi-automatic mode</p> <p>Second dash: If the loading/unloading device is not used, the compression moulding machine shall switch into a safe mode. The machine needs to be restarted again and there is no reason for the operator to use a manual load/unload process.</p> <p>Definitions for possible modes of operation (EUROMAP):</p> <p>(1) Manual Mode Where a machine is manually operated the functions of the machine are controlled via a hold-to-run control and are frequently possible only with reduced speeds/forces. Manual operation is used e.g. for setting; a production of parts is technically and economically not possible/sensible.</p> <p>(2) Semiautomatic Mode Semiautomatic operation is a type of operation where one cycle is completed automatically after a start signal, then the machine stops, the next cycle can only take place if a further start signal has been given. Semiautomatic operation is used mainly if manual loading/unloading of the mould(s) is required.</p> <p>(3) Fully automatic Mode Fully automatic operation is an operation where one cycle automatically follows the other; no intervention of the operator is necessary.</p>			

(1) Essential health and safety requirement

Note: According to point 6.6 of the Guide of the implementation of directives based on the New Approach and the Global Approach, the notified bodies apply as general guidance this recommendation for use.

	CO-ORDINATION OF NOTIFIED BODIES Machinery Directive 2006/42/EC + amendments RECOMMENDATION FOR USE		CNB/M/04.014 Revision: 08 Language: EN
Number of pages: 1 Origin: Injection or compression moulding machines	Date: 31.07.2023	To be approved by: <input checked="" type="checkbox"/> Vertical Group <input checked="" type="checkbox"/> Horizontal Committee To be endorsed by: <input checked="" type="checkbox"/> Machinery Expert Group	Approved on: 04.05.2023 31.05.2023 Endorsed on: 12.04.2024
Question related to: Directive 2006/42/EC Annex: I	Article: - EHSR (1): 1.1.2 (a); 1.5.14	EN/prEN: EN ISO 20430:2020 Normative clause: 4.2.8 CEN TC concerned: TC 145 / ISO 270	Other: - Other clause: -
Key words: Machine with fence and robot; crossing the mould area into the fenced area behind the machine			
Question: A horizontal machine, smaller than the dimensions given in clause 4.2.8 of EN ISO 20430 is equipped with a fence for a robot. Can we consider crawling through the machine (between the opened platens) into the fence area a reasonably foreseeable misuse?			
Solution: No, because: <ul style="list-style-type: none"> - A machine of this dimension cannot be entered by a person in the sense of the standard; if somebody makes an extreme effort to gain entry into the machines, this is not a reasonably foreseeable misuse; - A machine of larger dimensions must be equipped with additional safety measures according to clause 4.2.8 of EN ISO 20430. 			

(1) Essential health and safety requirement

Note: According to point 6.6 of the Guide of the implementation of directives based on the New Approach and the Global Approach, the notified bodies apply as general guidance this recommendation for use.

	CO-ORDINATION OF NOTIFIED BODIES Machinery Directive 2006/42/EC + amendments RECOMMENDATION FOR USE		CNB/M/04.029 Revision: 08 Language: EN
Number of pages: 1 Origin: Injection or compression moulding machines	Date: 31.07.2023	To be approved by: <input checked="" type="checkbox"/> Vertical Group <input checked="" type="checkbox"/> Horizontal Committee To be endorsed by: <input checked="" type="checkbox"/> Machinery Expert Group	Approved on: 04.05.2023 31.05.2023 Endorsed on: 12.04.2024
Question related to: Directive 2006/42/EC Annex: I	Article: - EHSR (1): 1.4.3	EN/prEN: EN ISO 20430:2020, cl. 6.2.4, 6.2.5 EN 289:2014, cl. 7.2.4 / 7.2.5 Normative clause: s.a. CEN TC concerned: CEN TC 145 / ISO TC 270	Other: - Other clause: -
Key words: Injection or Compression Moulding Machine Response Time			
Question: Is a manufacturer of an injection or compression moulding machine equipped with a light curtain or a two-hand control obliged to install an automatically working response-time-measurement system?			
Solution: No, In the C-standards EN 289 and EN ISO 20430 is no indication to do so. The manufacturer has to give information on the values of the response time and the corresponding distances in the user's manual. In addition, the manufacturer shall give the following information in the user's manual: <ul style="list-style-type: none"> - maximum closing speed, - maximum dimension of the mould, - information about the necessity of new evaluation of safety distances and response time after repair or adjustment or at least one a year. 			

(1) Essential health and safety requirement

Note: According to point 6.6 of the Guide of the implementation of directives based on the New Approach and the Global Approach, the notified bodies apply as general guidance this recommendation for use.

	CO-ORDINATION OF NOTIFIED BODIES Machinery Directive 2006/42/EC + amendments RECOMMENDATION FOR USE		CNB/M/04.040 Revision: 09 Language: EN
Number of pages: 1 Origin: Injection or compression moulding machines	Date: 31.07.2023	To be approved by: <input checked="" type="checkbox"/> Vertical Group <input checked="" type="checkbox"/> Horizontal Committee To be endorsed by: <input checked="" type="checkbox"/> Machinery Expert Group	Approved on: 04.05.2023 31.05.2023 Endorsed on: 12.04.2024
Question related to: Directive 2006/42/EC Annex: I	Article: - EHSR (1): 1.2.2	EN/prEN: EN ISO 20430:2020 Normative clause: 4.2.7 b) CEN TC concerned: CEN TC 145 / ISO TC 270	Other: - Other clause: -
Key words: automatic sequence control, guard closing, latch retracting, mould closing			
Question: Which sequence regarding guard closing - retracting the latch - mould closing shall be provided (sequence, kind of actuating device) for machines allowing whole body access?			
Solution: Principally, EN ISO 20430:2020, clause 4.2.7 b) provides the following sequence: 1. Separate retracting of the latch, i.e. actuation of a control device 2. Guard closing by actuating a further control device (here: hold-to-run control device). 3. After closing of a guard a further, third control device shall be actuated for closing the mould, as otherwise, this would be a gate start in accordance with clause 4.2.4. The VG 4 is of the opinion that it is not necessary to push 3 different command devices in sequence. As an alternative, the sequence can be organised as follows: 1.1 A hold-to-run control device ensures latch retraction and guard closing. As soon as the guard is closed, a further control device shall be actuated that initiates the mould closing. or 1.2 The actuation of the control device ensures latch retraction. Within 3 seconds after release of this control device a further control device shall be actuated for guard closing (hold-to-run). If this command device is released and actuated again after the door is closed, the closing of the mould shall be initiated. The control sequence has to be monitored at each cycle of the movable guard.			

(1) Essential health and safety requirement

Note: According to point 6.6 of the Guide of the implementation of directives based on the New Approach and the Global Approach, the notified bodies apply as general guidance this recommendation for use.

	CO-ORDINATION OF NOTIFIED BODIES Machinery Directive 2006/42/EC + amendments RECOMMENDATION FOR USE		CNB/M/04.053 Revision: 07 Language: EN
Number of pages: 1 Origin: VG 4 Injection and Compression Moulding Machines	Date: 03.07.2023	To be approved by: <input checked="" type="checkbox"/> Vertical Group <input checked="" type="checkbox"/> Horizontal Committee To be endorsed by: <input checked="" type="checkbox"/> Machinery Expert Group	Approved on: 09.06.2021 16.12.2021 Endorsed on: 23.03.2023
Question related to: Directive 2006/42/EC Annex: I	Article: - EHSR (1): 1.2.1	EN/prEN: EN 201:2009 / EN ISO 20430:2020 Normative clause: - / 4.1.2.1 TC concerned: CEN TC 145 / ISO TC 270	Other: - Other clause: -
Key words: 24 VDC hydraulic valves, protective bonding circuit connection on the voltage supply plug of a 24 VDC solenoid valve			
Question: Is it necessary to have a separate grounding wire to each 24 VDC solenoid valve?			
Solution: It is not necessary to have a separate grounding wire to each solenoid valve if all of the following conditions are fulfilled: <ul style="list-style-type: none"> - coils are supplied by separate winding transformer or equivalent - the coil of solenoid is coated in an insulating material - one side of the secondary output is connected to earth - the connector is made of plastic - an interconnection has to be done between the frame and the block supporting the valves either by wiring or by fixing the valves on the frame 			

(1) Essential health and safety requirement

Note: According to point 6.6 of the Guide of the implementation of directives based on the New Approach and the Global Approach, the notified bodies apply as general guidance this recommendation for use.

	CO-ORDINATION OF NOTIFIED BODIES Machinery Directive 2006/42/EC + amendments RECOMMENDATION FOR USE		CNB/M/04.076 Revision: 06 Language: EN
Number of pages: 1	Date: 03.07.2023	To be approved by:	Approved on:
Origin: VG 4 Injection and Compression Moulding Machines		<input checked="" type="checkbox"/> Vertical Group	09.06.2021
		<input checked="" type="checkbox"/> Horizontal Committee	16.12.2021
		To be endorsed by:	Endorsed on:
		<input checked="" type="checkbox"/> Machinery Expert Group	23.03.2023
Question related to: Directive 2006/42/EC	Article: -	EN/prEN: EN 201:2009 / EN ISO 20430:2020	Other: Annex C, G, H / Annex D, E
Annex: I	EHSR (1): 1.2.1	Normative clause: 5.2.1 / 4.2.1.1	Other clause: -
Key words: Plastics and rubber hydraulic IMM – horizontal mould closing movement – motor control unit			
<p>Question:</p> <p>The pump of the hydraulic circuit is driven by an electrical motor and its control unit (frequency converter or contactor). Is it possible to use as second shut-off device, defined in EN 201 / EN ISO 20430 type III, a motor control unit, a frequency converter or a contactor that switches-off the pump drive (the main power source for the horizontal closing movement of the platen) instead of a valve?</p>			
<p>Recommended solution:</p> <p>Yes, provided that:</p> <ul style="list-style-type: none"> • The opening of the guard shall activate the Safe Torque Off function (see definition in EN 61800-5-2:2017) of the motor control unit or switch-off the contactor. • The motor control unit Safe Torque Off function shall comply with the requirements of PL c, category 2 or 3 of EN ISO 13849-1:2015, and shall be tested by an independent laboratory accredited according to EN ISO/IEC 17025. • The contactor shall be directly connected to the motor and with linked or mirror control contacts. • The change of the signal of the switch-off coming from the motor control unit or the contactor shall be automatically monitored at least once during each cycle of the movable guard. • Commencement of any further cycle after closing of the movable guard shall be possible only if no faults have been detected. • The fault of the main shut-off device shall not create a dangerous run-down. • The only power source for the closing movement of the movable platen shall be the pump; no accumulators shall be installed on this line. 			

(1) Essential health and safety requirement

Note: According to point 6.6 of the Guide of the implementation of directives based on the New Approach and the Global Approach, the notified bodies apply as general guidance this recommendation for use.

	CO-ORDINATION OF NOTIFIED BODIES Machinery Directive 2006/42/EC + amendments RECOMMENDATION FOR USE		CNB/M/04.083 Revision: 07 Language: EN
Number of pages: 1	Date: 03.07.2023	To be approved by:	Approved on:
Origin: VG 4 Injection and Compression Moulding Machines		<input checked="" type="checkbox"/> Vertical Group	03.05.2022
		<input checked="" type="checkbox"/> Horizontal Committee	14.06.2022
		To be endorsed by:	Endorsed on:
		<input checked="" type="checkbox"/> Machinery Expert Group	23.03.2023
Question related to: Directive 2006/42/EC	Article: -	EN/prEN: EN ISO 20430:2020	Other: -
Annex: I	EHSR (1): 1.5.14	Normative clause: 4.2.7, 4.2.8	Other clause: -
TC concerned: CEN TC 145 / ISO TC 270			
Key words: Injection moulding machines with tie bar distances >1200 mm; person standing behind the mould at the rear side of the machine or entering the mould area from the operator's side			
Question: A machine manufacturer constructs, or retrofits an injection moulding machine having a tie bar distance H >1200mm with a robot on the machine's rear side. In compliance with the standard's specifications, the machine is equipped with an additional safeguarding system in the mould area (e.g. mats). Due to the large dimensions of the enclosed area or the tools installed on site, a person entering the fenced area of the robot from the operator's side or being in the area between the mould and the mobile guard might not be sufficiently visible from the operator's side. What are the measures the machine manufacturer or retrofitter has to take if a situation as the one described above is possible on a machine with H>1200mm? Additional Information: This matter was raised by a machine manufacturer as manufacturers often have to issue the final conformity assessment after having retrofitted a machine at the customer's plant. There is already a data sheet existing which deals with this subject: CNB/M/04.014; however, this data sheet refers exclusively to machines with H<1200mm. Thus, this sheet fails to apply to a dimension of H>1200mm EN ISO 10218-2 describes principals of safety requirement of industrial robot systems and their integration in industrial lines with machines and robot-cells. For alternatives for the safeguarding of the described situation, this standard might be considered.			
Solution: 1) A person entering the enclosed area of the robot from the operator's side of the injection moulding machine (IMM) needs to pass an ESPE (mono-beam or multi-beam). Following actuation of this ESPE, an acknowledgment action is necessary at this place before it is possible to start the next machine cycle on the operator's side. An additional pressure-sensitive mat shall be provided on the place where the operator might stay behind the mould between the mould and the rear guard of the machine; this mat shall ensure that although the ESPE has not yet been interrupted the person is detected, and thus prevent initiation of the next machine cycle. or 2) A double acknowledgment system as described in EN ISO 20430:2020, Annex F.2 with the first push located at a position from which a good view of the area hidden by the mould and / or the area of the handling device is possible. The acknowledgment procedure has to be required automatically by the control system of the machine every time the safety device in the mould area has been actuated. For that reason, this solution could only be used for machines that usually work in fully automatic mode.			

(1) Essential health and safety requirement

Note: According to point 6.6 of the Guide of the implementation of directives based on the New Approach and the Global Approach, the notified bodies apply as general guidance this recommendation for use.

	CO-ORDINATION OF NOTIFIED BODIES Machinery Directive 2006/42/EC + amendments RECOMMENDATION FOR USE		CNB/M/04.085 Revision: 07 Language: EN
Number of pages: 1	Date: 03.07.2023	To be approved by:	Approved on:
Origin: VG 4 Injection and Compression Moulding Machines		<input checked="" type="checkbox"/> Vertical Group	03.05.2022
		<input checked="" type="checkbox"/> Horizontal Committee	14.06.2022
		To be endorsed by:	Endorsed on:
		<input checked="" type="checkbox"/> Machinery Expert Group	23.03.2023
Question related to: Directive 2006/42/EC	Article: -	EN/prEN: EN ISO 20430:2020	Other: -
Annex: I	EHSR (1): 1.2.1	Normative clause: 4.3.1	Other clause: -
TC concerned: CEN TC 145 / ISO TC 270			
Key words: Mould opening for machines with horizontal closing movement and electrical axis			
<p>Question:</p> <p>Clause 5.3.1 allows the opening movement of the platen when the guards for the mould area are open or the light curtains are interrupted, or the manual actuators of any two hands control device are released. For electrical axis in this situation, a single fault can generally create a change of the direction, because of the bypassing of guard interlocking system, so the opening movement can unexpectedly change to closing movement.</p> <p>How is it possible to prevent that this malfunction can create hazards for machines with horizontal closing movement and electrical axis?</p>			
<p>Solution:</p> <p>To avoid this malfunction the following steps are necessary:</p> <ol style="list-style-type: none"> 1. detection of wrong direction 2a. then stop the movement with a maximum closing distance of 6mm 2b. then remove power or activate the safety function (STO) to prevent unexpected start <p>These steps can be realised by implementing the following circuits:</p> <ul style="list-style-type: none"> • a direction monitoring circuit according to EN ISO 13849-1 PL=e and • a stopping performance monitoring circuit according to EN ISO 13849-1 PL= d • and an axis power removal circuit according to EN ISO 13849-1 PL=e <p>These safety functions can separately be done by a safety device or integrated e.g. in the frequency converter</p> <p>If during the opening movement a wrong direction occurs, than</p> <ol style="list-style-type: none"> 1. the axis shall stop in 6 mm maximum in the worst conditions (mass, speed, etc.) and 2. power removal or safety function (STO) shall be activated. <p>External mechanical brakes can be used. They shall be mechanically linked to the platen using well-tried safety principles. Circuits driving the brake systems shall be designed and monitored according to the needs of the safety control system.</p> <p>Fail safe brake systems shall be used and a test of the brake performance has to be done to show the sufficient friction of the brake. If this test is done in a stand still position, it must be shown that also the stopping time under worst-case conditions will be guaranteed. The interpretation of the test result must be done by the safety control system.</p> <p>The test has to be done</p> <ul style="list-style-type: none"> • at each power on, • at each change of operational mode to enable or disable this function and • after eight hours of operation 			

(1) Essential health and safety requirement

Note: According to point 6.6 of the Guide of the implementation of directives based on the New Approach and the Global Approach, the notified bodies apply as general guidance this recommendation for use.

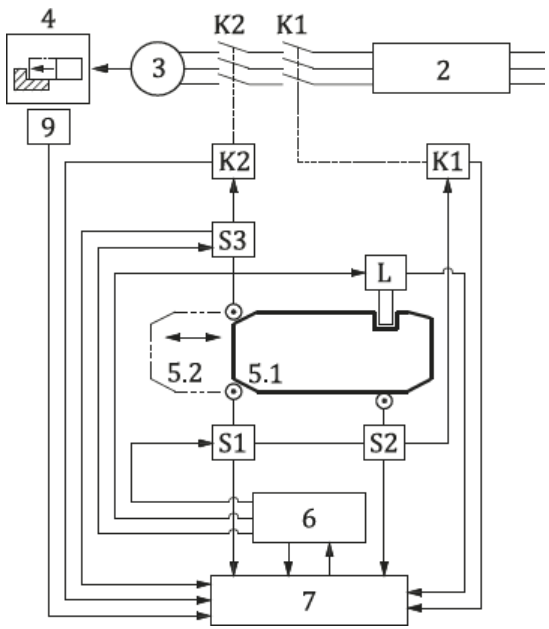
		CO-ORDINATION OF NOTIFIED BODIES Machinery Directive 2006/42/EC + amendments		CNB/M/04.086 Revision: 07 Language: EN	
RECOMMENDATION FOR USE					
Number of pages: 1		Date: 03.07.2023		To be approved by:	
Origin: VG 4 Injection and Compression Moulding Machines		<input checked="" type="checkbox"/> Vertical Group <input checked="" type="checkbox"/> Horizontal Committee To be endorsed by: <input checked="" type="checkbox"/> Machinery Expert Group		Approved on: 03.05.2022 14.06.2022 Endorsed on: 23.03.2023	
Question related to: Directive 2006/42/EC Article: -		EN/prEN: EN ISO 20430:2020		Other: -	
Annex: I		EHSR (1): 1.2.1		Normative clause: 4.1.4.3	
		TC concerned: CEN TC 145 / ISO TC 270		Other clause: -	
Key words: Electrical axis; Guard locking; detection of standstill					
Question: For machine with electrical axis, guard locking can be necessary. Clause 4.1.4.3 specifies that the detection of standstill shall be safe against single fault. 1. What is the standstill detection circuit? 2. How can a “permanent automatic monitoring of the change of position of the platen by means of a motor encoder” be safe against single fault?					
Solution: Principal remark: the term “safe against single fault” in the sense of EN ISO 20430:2020; clause 4.1.4.3 describes a dual channel system but does not specify or require a quality of this system. 1. The standstill detection circuit, is the circuit that detects the axis at the rest and gives the signal for the unlocking of the guard. In the example below the standstill detection circuit is composed by: items n.9, n.7, n.6 and signals transmission components.					
					
2. Safe against single fault means, that if the fault of the detection control circuit can unlock the guard when the axis is still moving, the locking device shall be monitored and a stop signal shall be immediately generated for the electrical axes every time the locking device is unlocked.					





(1) Essential health and safety requirement

Note: According to point 6.6 of the Guide of the implementation of directives based on the New Approach and the Global Approach, the notified bodies apply as general guidance this recommendation for use.

	CO-ORDINATION OF NOTIFIED BODIES Machinery Directive 2006/42/EC + amendments RECOMMENDATION FOR USE		CNB/M/04.087 Revision: 06 Language: EN
Number of pages: 1	Date: 03.07.2023	To be approved by:	Approved on:
Origin: VG 4 Injection and Compression Moulding Machines		<input checked="" type="checkbox"/> Vertical Group	03.05.2022
		<input checked="" type="checkbox"/> Horizontal Committee	14.06.2022
		To be endorsed by:	Endorsed on:
		<input checked="" type="checkbox"/> Machinery Expert Group	23.03.2023
Question related to: Directive 2006/42/EC	Article: -	EN/prEN: EN ISO 20430:2020	Other: -
Annex: I	EHSR (1): 1.5.1	Normative clause: 4.8.4	Other clause: -
TC concerned: CEN TC 145 / ISO TC 270			
Key words: Plug and socket combinations for subunits on injection moulding machines			
Question: Are plug and socket combinations considered to be physically connected or disconnected during load conditions, if these combinations are only used to connect subunits of the system?			
Solution: The plug and socket combinations are not considered to be physically connected or disconnected during load conditions if the following applies: <ol style="list-style-type: none"> a) The installation/maintenance manual states that the plug and socket combination shall not be connected or disconnected during load conditions. b) The manufacturer shall describe the procedure for disconnection, for example by the use of <ul style="list-style-type: none"> • The main switch of the injection moulding machine or • A maintenance switch for this circuit of the injection moulding machine or • A switch of the subunit to be connected/disconnected which assures that a current flow is prevented. Note: The requirements of EN 60204-1; cl.13.4.5 shall be fulfilled.			

(1) Essential health and safety requirement

Note: According to point 6.6 of the Guide of the implementation of directives based on the New Approach and the Global Approach, the notified bodies apply as general guidance this recommendation for use.

	CO-ORDINATION OF NOTIFIED BODIES Machinery-Directive 2006/42/EC + Amendment RECOMMENDATION FOR USE		CNB/M/05.201 Revision 03 Language: E
Date of first stage: 23/06/1997	To be approved by :		Approved on :
Origin: VG5 Machines for underground work	<input checked="" type="checkbox"/> Vertical Group <input checked="" type="checkbox"/> Horizontal Committee.....	03/11/2009 13/12/1995	
Question related to: Directive 2006/42/EC Article: Annex: IV, 12.2 ESR (1):		EN/prEN: Clause: CEN TC concerned:	Other: Other clause:
Key words: Hydraulic powered roof support			
Question: Which types of machine are classed as "hydraulic powered roof supports"?			
Solution: Types of machines classed as "hydraulic powered roof supports" are : <ul style="list-style-type: none">  one support unit under adjacent control  several support units under group control  entire coal face support under central control Coal-getting machines and hoisting engines are excluded.			
Adaptation procedure: FORMAL ADAPTATION IN CONFORMITY WITH DIRECTIVE 2006/42/EC			

(1) Essential safety requirement

Note: According to point 6.6 of the Guide of the implementation of directives based on the New Approach and the Global Approach, the notified bodies apply as general guidance this recommendation for use.

	<p style="text-align: center;">CO-ORDINATION OF NOTIFIED BODIES Machinery-Directive 2006/42/EC + Amendment</p> <p style="text-align: center;">RECOMMENDATION FOR USE</p>	<p>CNB/M/05.202 Revision 02 Language : E</p>
Date of first stage: 30/05/1995	To be approved by :	Approved on :
Origin: VG5 Machines for underground work	<input checked="" type="checkbox"/> Vertical Group <input checked="" type="checkbox"/> Horizontal Committee.....	 03/11/2009 13/12/1995
	To be endorsed by: <input checked="" type="checkbox"/> Machinery Working Group....	 Endorsed on : 04/06/1996
Question related to: Directive 2006/42/EC	Article:	EN/prEN:
Annex:	ESR (1):	Other:
	Clause:	Other clause:
	CEN TC concerned:	
Key words: Hydraulic powered roof support, components with safety function, safety components		
Question:		
Which are the components with safety function/safety components for hydraulic powered roof support?		
Solution:		
safety components - examples		
support units: canopy, gob shield, base etc.		
hydraulic rams: rams, adjusting cylinders, canopy cylinders		
hydraulic control devices: check valves, pressure limitation valves (yield valves), control valves for setting props, retracting, alignment, advancing		
electro hydraulic control devices: discrete control devices, emergency off devices, sensors which initiate movements, master control devices, software		
<p>Adaptation procedure: FORMAL ADAPTATION IN CONFORMITY WITH DIRECTIVE 2006/42/EC</p>		

(1) Essential safety requirement

Note: According to point 6.6 of the Guide of the implementation of directives based on the New Approach and the Global Approach, the notified bodies apply as general guidance this recommendation for use.

	CO-ORDINATION OF NOTIFIED BODIES Machinery-Directive 2006/42/EC + Amendment RECOMMENDATION FOR USE		CNB/M/05.208 Revision 03 Language: E
Date of first stage: 23/06/1997 Origin: VG5 Machines for underground work	To be approved by : <input checked="" type="checkbox"/> Vertical Group <input checked="" type="checkbox"/> Horizontal Committee..... To be endorsed by: <input checked="" type="checkbox"/> Machinery Working Group....	Approved on : 03/11/2009 12/12/1995 Endorsed on : 04/06/1996	
Question related to: Directive 2006/42/EC Article: Annex: ESR (1):	EN/prEN: Clause: CEN TC concerned:	Other: Other clause:	
Key words: Hydraulic powered roof support, placing on the market, putting into service			
Question: What are the most common manufacturing, modification and repair combinations by which new/modified or used hydraulic powered roof supports are placed on the market ?			
Solution: Placing on the market, putting into service of hydraulic powered roof supports: Cases a) new hydraulic powered roof support one manufacturer b) new hydraulic powered roof support several manufacturers c) used hydraulic powered roof support original manufacturer modifies type d) used hydraulic powered roof support non-original manufacturer modifies type e) unchanged type of hydraulic powered roof support authorized before 01-01-95 is placed on the market anew. Adaptation procedure: FORMAL ADAPTATION IN CONFORMITY WITH DIRECTIVE 2006/42/EC			

(1) Essential safety requirement

Note: According to point 6.6 of the Guide of the implementation of directives based on the New Approach and the Global Approach, the notified bodies apply as general guidance this recommendation for use.

	CO-ORDINATION OF NOTIFIED BODIES Machinery-Directive 2006/42/EC + Amendment RECOMMENDATION FOR USE	CNB/M/05.220 Revision 05 Language: E
Date of first stage: 19/01/2001	To be approved by:	Approved on:
Origin: VG5 Machines for underground work	<input checked="" type="checkbox"/> Vertical Group	03/11/2009
	<input checked="" type="checkbox"/> Horizontal Committee.....	07/12/2000
Question related to: Directive 2006/42/EC Article: Annexes: IV, 12.2, IX ESR (1):	EN/prEN:	Other:
	Clause:	Other clause:
Key words: Hydraulic powered roof support, support unit, technical file, EC-type examination		
Question: What is a representative model for the EC-type examination procedure of different types of hydraulic powered roof support machinery?		
Solution: 1) New hydraulic powered roof support as a whole or parts of it have to comply in any case with all applicable requirements of the directive before being placed on the market (e.g. EC-type examination if harmonised standards are not used). 2) In the case of replacement of components with safety function of hydraulic powered roof supports like legs, hydraulic control system or structural steel elements, which do not change the function, the person who replaces the components of the machine shall ensure the compatibility of these components. The replaced component shall be type tested and a certificate shall be issued by a notified body. A new EC-type examination certificate for the entire machine is not necessary. 3) In the case of replacement of components which change the function of the machine (e.g. changing of the media bearing force, automation of motions, change of dimensions) a new EC-type examination certificate is required. The tests required shall be specified in each case. Generally the tests cover the components themselves, the respective interfaces and the changes of function caused thereby. 4) New hydraulic powered roof support machines require EC-type examination certificates before they may be placed on the market regardless of whether identical machines placed on the market before January 1, 1995 had been homologated by a national authority. Existing test reports shall be recognised. The extend of additional tests and the documentation required shall be specified in each case. 5) The application for an EC-type examination shall include the following documentation: - for support units according to recommendation for use CNB/M/05.204/R/E, rev. 02, 19.11.1996 - for hydraulic control systems and valves according to recommendation for use CNB/M/05.205/R/E, rev. 02, 19.11.96 - for electro hydraulic control systems and components according to recommendation for use CNB/M/05.206/R/E, rev 02, 19.11.1996 - for legs and rams within the flow of the media bearing force according to recommendation for use CNB/M/05.207, rev. 02, 19.11.1996 Adaptation procedure: FORMAL ADAPTATION IN CONFORMITY WITH DIRECTIVE 2006/42/EC		

(1) Essential safety requirement

Note: According to point 6.6 of the Guide of the implementation of directives based on the New Approach and the Global Approach, the notified bodies apply as general guidance this recommendation for use.

	CO-ORDINATION OF NOTIFIED BODIES Machinery-Directive 2006/42/EC + Amendment RECOMMENDATION FOR USE	CNB/M/05.222 Revision 04 Language: E
Date of first stage: 19/01/2001	To be approved by:	Approved on:
Origin: VG5 Machines for underground work	<input checked="" type="checkbox"/> Vertical Group	03/11/2009
	<input checked="" type="checkbox"/> Horizontal Committee.....	07/12/2000
Question related to: Directive 2006/42/EC Article: Annex: IV, 12.2, and Annex I ESR (1): 1.7.4	To be endorsed by:	Endorsed on :
	<input checked="" type="checkbox"/> Machinery Working Group....	04/01/2005
	EN/prEN:	Other:
	Clause:	Other clause:
	CEN TC concerned:	
Key words : hydraulic powered roof support, pressure supply, EC-type examination		
Question : Is it necessary to include the pressure supply in the EC-type examination of hydraulic powered roof support?		
Solution : No. Normally hydraulic powered roof support units are not used alone but some hundreds as assembly. Up to now the pressure supply of hydraulic powered roof support is not part of an EC-type examination. although high risks can occur there. This should be mentioned in the instructions for the machinery as described in Annex I, 1.7.4.		
Adaptation procedure: FORMAL ADAPTATION IN CONFORMITY WITH DIRECTIVE 2006/42/EC		

(1) Essential safety requirement

Note: According to point 6.6 of the Guide of the implementation of directives based on the New Approach and the Global Approach, the notified bodies apply as general guidance this recommendation for use.

	CO-ORDINATION OF NOTIFIED BODIES Machinery-Directive 2006/42/EC + Amendment RECOMMENDATION FOR USE		CNB/M/05.601 Revision 05 Language: E
Date of first stage: 19/01/2001	To be approved by:	Approved on:	
Origin: VG5 Machines for underground work	<input checked="" type="checkbox"/> Vertical Group <input checked="" type="checkbox"/> Horizontal Committee.....	03/11/2009 07/12/2000	
Question related to: Directive 2006/42/EC Article: Annexes: IV, 12.1 ESR (1):	EN/prEN: EN 1889-2:2003/A1:2009 Clause: CEN TC concerned:	Other: Other clause:	
Key words : locomotive, EC-type examination, running test			
Question : In EN 1889-2:2003/A1:2009, running tests for locomotives have been provided. However there is no suitable test course available on the surface. How, when and where can these tests be realized?			
Solution : <p>1. In the type test, the notified body shall check, if the locomotive fulfils the requirements for safe running in principle. In particular the notified body shall prove the adaptability of the running gear/bogie including the brake system relating to the relevant demands in underground working.</p> <p>2. As far as running tests can not be realized on the surface completely, the missing tests have to be carried out at the beginning of putting the locomotive in operation underground. All these relevant checks, the duty for careful realization of these checks and their documentation have to be specified in the operators manual. The notified body has to be involved with, at least he must get the required documentation for proving.</p> <p>Adaptation procedure: FORMAL ADAPTATION IN CONFORMITY WITH DIRECTIVE 2006/42/EC</p>			

(1) Essential safety requirement

Note: According to point 6.6 of the Guide of the implementation of directives based on the New Approach and the Global Approach, the notified bodies apply as general guidance this recommendation for use.

	CO-ORDINATION OF NOTIFIED BODIES Machinery-Directive 2006/42/EC + Amendment RECOMMENDATION FOR USE	CNB/M/05.603 Revision 05 Language: E
Date of first stage: 19/01/2001 Origin: VG5 Machines for underground work	To be approved by: <input checked="" type="checkbox"/> Vertical Group <input checked="" type="checkbox"/> Horizontal Committee..... To be endorsed by: <input checked="" type="checkbox"/> Machinery Working Group....	Approved on: 03/11/2009 07/12/2000 Endorsed on : 04/01/2005
Question related to: Directive 2006/42/EC Article: Annex: I ESR (1):	EN/prEN: Clause: CEN TC concerned:	Other: Other clause:
Key words: locomotive, EC type examination certificate, putting into operation, control		
Question: Is it possible for a notified body to prescribe in his certificate (or test report) for a locomotive the way of putting into operation and the type of control?		
Solution: A notified body may require the instructions to include details of putting into operation and the type of control if this can affect the safe working of a locomotive.		
Adaptation procedure: FORMAL ADAPTATION IN CONFORMITY WITH DIRECTIVE 2006/42/EC		

(1) Essential safety requirement

Note: According to point 6.6 of the Guide of the implementation of directives based on the New Approach and the Global Approach, the notified bodies apply as general guidance this recommendation for use.

	CO-ORDINATION OF NOTIFIED BODIES Machinery Directive 2006/42/EC + amendments RECOMMENDATION FOR USE		CNB/M/06.016 Revision: 09 Language: EN
Number of pages: 1	Date: 23.01.2023	To be approved by:	Approved on:
Origin: VG6 Refuse collection vehicles		<input checked="" type="checkbox"/> Vertical Group <input checked="" type="checkbox"/> Horizontal Committee To be endorsed by: <input checked="" type="checkbox"/> Machinery Expert Group	22.06.2022 18.12.2023 Endorsed on: 12.04.2024
Question related to: Directive 2006/42/EC	Article: -	EN/prEN: EN 1501-1:2021	Other: EN 60204-1:2018
Annex: I	EHSR (1): 1.6.3 and 3.5.1	Normative clause: 5.8.3 CEN TC concerned: TC 183	Other clause: -
Key words: Refuse collection vehicle (RCV) - energy separation main switch			
Question: What are the conditions for the statutory objective as defined in EHSR 1.6.3 (Isolation of energy sources) to be considered as having been fulfilled?			
Recommended solution: Due to EN 1501-1:2021 clause 5.8.3 a separate main switch for the body work conform to EN 60204-1:2018 shall be fitted. Additional the hydraulic pump shall be switched ineffective either by switching off (e.g. electromagnetic clutch) or electro-hydraulic bypassing. The main switch for the body work must be lockable in the off-position. Note: For the colour of the main switch, see 5.3.3 of EN 60204-1:2018.			

(1) Essential health and safety requirement

Note: According to point 6.6 of the Guide of the implementation of directives based on the New Approach and the Global Approach, the notified bodies apply as general guidance this recommendation for use.

	CO-ORDINATION OF NOTIFIED BODIES Machinery Directive 2006/42/EC + Amendment RECOMMENDATION FOR USE		CNB/M/06.023 Revision 08 Language: E
Date of first stage: 25/07/1997	To be approved by:		Approved on:
Origin: VG6 Refuse collection vehicles	<input checked="" type="checkbox"/> Vertical Group <input checked="" type="checkbox"/> Horizontal Committee		15/04/2015 24/06/2015
Question related to: Directive 2006/42/EC Article: Annex: I ESR (1): 1.5.3 and 1.5.5	EN 1501-1:2011 Clause: 5.3.2 CEN TC concerned: TC 183		Other: Other clause:
Key words: Refuse collection vehicle (RCV) - Hose burst protection valves			
Question: What kind of hose burst protection valves can be approved regarding the writing in EN 1501-1: 2011 Are simple lock valves (spring loaded) acceptable? Or is a more sophisticated lowering device required?			
Solution: To prevent raised tailgates from falling caused by hose bursts, any type of safety valve (e.g. like flow sensitive check valves) fulfilling the test requirements is acceptable, if they are fitted directly to the lifting rams of tailgates. The valves are to be thoroughly tested during the EC type examination, ensuring that in the event of a hose burst on one side only, both valves have to operate in sufficient time to minimise any distortion on the tailgate hinges. It is strongly recommended that manufacturers conduct the same tests on each RCV produced.			
Adaptation procedure: FORMAL ADAPTATION IN CONFORMITY WITH DIRECTIVE 2006/42/EC			

The footboard shall be secure against unintended folding down which can cause an unintended braking down. When folding is powered the powering force shall be limited to 75 N measured at any point where a person can stand on. The folding speed measured at the rear of the footboard shall not exceed 0,6 m/sec. Thus to avoid injuries to the operative's leg when getting off the footboard and the relevant control is activated. The operation control shall be of hold-to-run-type and shall be located at the rear wall of the tailgate and in the cab.

2.1.2 weight indication:

In case of weight indication the restrictions shall be effective when a vertical force of at least 300 N acts onto the footboard totally folded down or its carrying structure in a minimum distance away from the pivoting hinge as a foot can stand on. Riding on the moveable footboard carrying structure when the footboard is folded down as well as on the fix carrying structure in any case shall be prevented by design. Easy bypassing the weight indication by supporting the footboard by means of a rope, chain, etc. or blocking it in a position not folded out totally shall be prevented by the design. The weight indication will only be accepted when the capability of easy bypassing, e. g. as mentioned above is permanently prevented.

The weight detection shall be effective at any temperature the RCV is designed for as stated in the "information for use" (operator's manual) with no drift of the forces. The period of necessary readjustment shall be stated in the "information for use" (operator's manual) and should not be less than the normal inspection period given in the user's manual.

Further more there shall no facility in easy reach of the footboard where on the operative can support himself to reduce his weight force acting on the footboard.

2.1.3 space indication

In case of space indication the operative shall be detected at any position on the footboard or its carrying structure independent from his cloth's colour and performance. Nothing else than a person positioned on the footboard shall be detected particularly other traffic participants (vehicles or pedestrians) or the road itself, when the footboard is folded down.

The space indication shall be effective at any temperature the RCV is designed for as stated in the "information for use" (operator's manual) with no drift of the detected area and no reduce of the detecting sensitivity.

2.1.4 Braking requirements for systems as described under 2.1.1 to 2.1.3:

Jumping onto the footboard during reversing up to 6 km/h shall stop the RCV within the distance between the rear edge of the footboard and the rear point of the rear wheel (see figure below).

At higher speeds the braking shall also be activated and the stopping distance may become longer but as short as possible.

This shall be measured on a dry horizontal even ground.

2.2 Restrictions

When one or both footboards are detected as occupied following restrictions shall apply:

- speed limitation on forward motion of the RCV up to 30 km/h, tested by means of the chassis own tachograph.
- prevention of reverse of the RCV in any case (see RFU 06.031).
- prevention of operating the lifting device when provided. This does not apply when the risk of unintentionally being crushed or sheared is prevented by a sufficient safeguard.
- prevention of operating the compaction mechanism in the automatic mode on an open system according to EN 1501-1.
- after use of the footboard automatic restart of bodywork or chassis functions shall be prevented.

(See also EN 1501-1)

2.3 Monitoring control:

2.3.1 Examining that part of the monitoring control which is origin part of the chassis is not task of the notified body performing an EC-type-examination. It shall only be tested according to its function.

2.3.2 The entire control including the detectors shall be designed not to be rendered ineffectively or to set out of operation by simple tools according to EN 1088. Particularly cutting a wire, disconnecting a plug connection out of a screwed box, removal of a detector, shadow respective making blind a sensor for space indication, and a failure of one component of the footboard monitoring control shall lead to the restrictions be effective (One failure safe). This shall be in accordance with the category 3 of the standard EN ISO 13849-1:2008.

To avoid manipulation, the check of the footboard control shall be made after each engine stop, at least before the compaction mechanism or /and the lifting device can be started. This check may not be the precondition for the chassis to drive faster than 30 km/h.

2.3.3 Environmental influences e.g. spot lights, part of trees approach of other vehicles, shall not lead to the restrictions be effective.

2.3.4 Cables and wires out of boxes shall withstand the environmental influences and shall be protected against mechanical damages. Components located on the outer surface of the RCV shall comply with IP 65 according to EN 60529+A1:2002.

2.3.5 To enable reverse in case of the monitoring system is destroyed e.g. by a traffic accident a push button shall be provided in the cab which bypasses the reverse restriction and prevents the operation of the bodywork including lifting device. Resetting shall only be possible by a key which shall not be identically with the ignition key or the cab door key. The push button shall be sealed. The "information for Use"

(operator's manual) shall state that the key shall be separated from the RCV. Resetting the push button it shall take at least 5 minutes before the RCV is ready for use again.

2.4 Communications

The working area needed to be observed including the footboards. Therefore the Closed Circuit Television System (CCTV) mentioned in 5.12.1. of EN 1501-1 shall not be capable of switching off during work and transport at any time when the ignition key is switched on.

2.5 Warning

To avoid traffic accidents by the slow going vehicle the flashing beacon according to 7.1.2.2 of prEN 1501-1: 2011 shall be engaged automatically when the footboards are occupied or the bodywork is switched on.

(National traffic rules shall be considered)

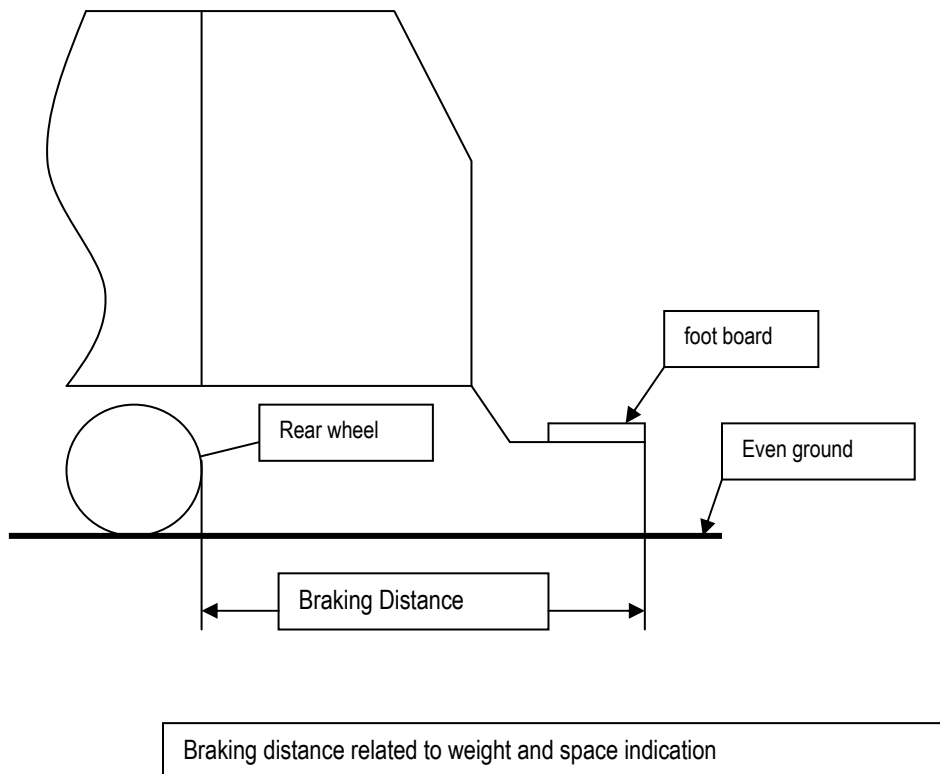

	CO-ORDINATION OF NOTIFIED BODIES Machinery Directive 2006/42/EC + Amendment RECOMMENDATION FOR USE	CNB/M/06.043 Revision 03 Language: E
Date of first stage: 20/05/2008	To be approved by:	Approved on:
Origin: VG6 Refuse Collection Vehicles	<input checked="" type="checkbox"/> Vertical Group <input checked="" type="checkbox"/> Horizontal Committee To be endorsed by: <input checked="" type="checkbox"/> Machinery Working Group....	20/05/2008 09/12/2008 Endorsed on: 04/07/2012
Question related to: Directive 2006/42/EC Article: 6, 12 Annexes: II, IV ESR (1):	EN/prEN: EN 1501-5:2011, EN1501-1:2011 Clause: CEN TC concerned:	Other: Other clause:
Key words: Element intended to be incorporated / carrying chassis / EC type-examination / EC declaration of conformity		
Question: Which is the scope of the EC type-examination and which is the content of the EC declaration of conformity of a Refuse Collection Vehicle (RCV) installed on a carrying chassis, in the following configurations: <ol style="list-style-type: none"> 1) RCV Annex IV without lifting devices or without predisposition for receiving one or many lifting devices 2) RCV Annex IV with integrated lifting devices 3) RCV Annex IV predisposed for receiving interchangeable lifting devices 		
Solution: <u>Answer to configuration 1):</u> EC type-examination (A) of the RCV, EC declaration of conformity according to Annex II A. and CE marking for the RCV (B) <u>Answer to configuration 2):</u> EC type-examination (A) of the RCV including the lifting device(s), EC declaration of conformity according to Annex II A. and CE marking for the RCV including the lifting device(s) (B) <u>Answer to configuration 3):</u> EC type-examination (A) of the RCV with its predispositions for receiving an interchangeable lifting device which is compatible with the RCV *, both manufacturers have to deliver their own declaration of conformity (for RCV declaration of conformity (II A) and lifting device declaration of conformity (II A) as an interchangeable equipment. (A): EC type-examination and EC type-certificate issued by a Notified Body; this EC type-certificate makes a copy of the conclusions of the EC type-examination and mentions the conditions and the limitations which restrict the extent of the documents, e.g. minimal width of the chassis to allow mounting of footboards. (B): Placing on the market of the RCV: EC declaration of conformity according to Annex II A. and CE marking are of the responsibilities of the manufacturer * Note: The compatibility is given if the manufacturer of the lifting device and the manufacturer of the RCV use a defined interface (hydraulically, pneumatically, electrically and mechanically), e. g. an interface according to EN 1501-5:2011		

(1) Essential safety requirement

Note: According to point 6.6 of the Guide of the implementation of directives based on the New Approach and the Global Approach, the notified bodies apply as general guidance this recommendation for use.

	CO-ORDINATION OF NOTIFIED BODIES Machinery Directive 2006/42/EC + amendments RECOMMENDATION FOR USE		CNB/M/06.047 Revision: 02 Language: EN
Number of pages: 1	Date: 03.07.2023	To be approved by:	Approved on:
Origin: VG6 Refuse collection vehicles		<input checked="" type="checkbox"/> Vertical Group <input checked="" type="checkbox"/> Horizontal Committee To be endorsed by: <input checked="" type="checkbox"/> Machinery Expert Group	02.06.2021 16.12.2021 Endorsed on: 23.03.2023
Question related to: Directive 2006/42/EC	Article: 1.1.2	EN/prEN: 1501-1:2021	Other: -
Annex: -	EHSR (1): -	Normative clause: 5.2 CEN TC concerned: TC 183 WG2	Other clause: -
Key words: Danger zone / Visibility / testing			
Question: How to ensure and evaluate the danger zone as described in EN1501-1 clause 5.2.2			
Solution: Visibility test should be done without any obstacle in the evaluated danger zones. Verification measurement shall be made with a vertical test object of 1,2 m height with a suitable width of 150 mm. For each danger zone identified in the following schematics, it shall be checked whether the test object is visible or detectable from the driver position or the operator working station on the whole boundary of the zone. The test object is considered to be visible in the following conditions: <ul style="list-style-type: none"> - There is no masking, or - Masking is smaller or equal to 200 mm height length. Note: masking smaller or equal to 200mm height length means an object higher than 1m is visible.			

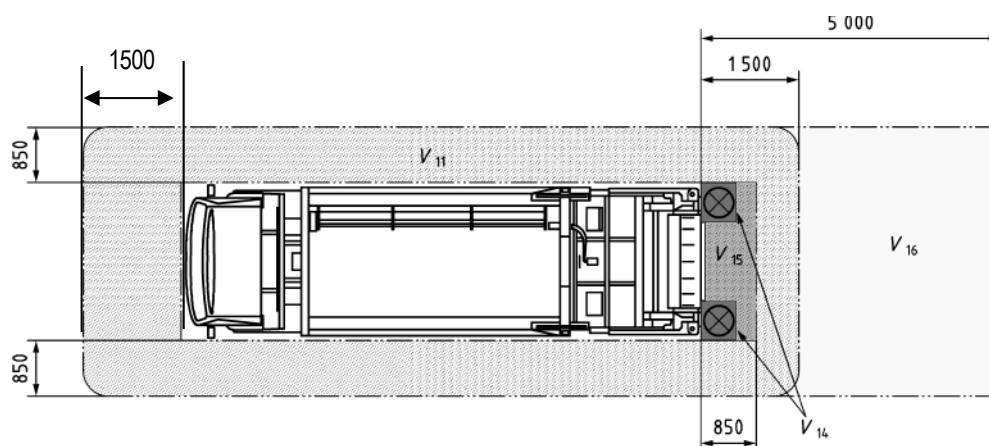

(1) Essential health and safety requirement

Note: According to point 6.6 of the Guide of the implementation of directives based on the New Approach and the Global Approach, the notified bodies apply as general guidance this recommendation for use.

	CO-ORDINATION OF NOTIFIED BODIES Machinery Directive 2006/42/EC + amendments RECOMMENDATION FOR USE		CNB/M/06.050 Revision: 02 Language: EN
Number of pages: 1 Origin: VG 6 Refuse Collection Vehicles	Date: 31.07.2023	To be approved by: <input checked="" type="checkbox"/> Vertical Group <input checked="" type="checkbox"/> Horizontal Committee To be endorsed by: <input checked="" type="checkbox"/> Machinery Expert Group	Approved on: 12.05.2023 31.05.2023 Endorsed on: 12.04.2024
Question related to: Directive 2006/42/EC Annex: -	Article: - EHSR (1): -	EN/prEN: EN 1501-1:2021 Normative clause: 5.10.3.4.3 CEN TC concerned: TC 183	Other: - Other clause: -
Key words: Rolling backward / detection / footboard not in unusable position			
<p>Question:</p> <p>* EN 1501-1 :2021, §5.10.3.4.3 requires that rolling backwards shall be detected when footboard(s) not in unusable position in order to alert the driver and cause him to stop the vehicle within 1 second after warning signal has been activated. If the driver will not stop within 1 second, the control must block the collection mechanism for 60 minutes.</p> <p>However, no maximum time delay or maximum distance the vehicle may roll is specified in 5.10.3.4.3 until the reverse rolling must be detected and before the warning must be activated.</p> <p>Which criteria should be applied by NB during EC type examination?</p>			
<p>Solution:</p> <p>It shall be verified that rolling backwards is detected if:</p> <ul style="list-style-type: none"> - the backwards speed is higher than 0,2 km/h and not more than 2 km/h. - that the maximum distance travelled after speed detection before the brakes are activated or a warning is given to the driver shall not exceed more than 80 cm. <p>*Additional Information:</p> <p>A footboard is <u>not in unusable position</u> if it is not totally folded up, so that a person could ride on it. The penalty time of 60 minutes will give no benefit to the rcv crew. It aims to avoid foreseeable misuse of the footboard (e.g. jumping on footboard during reversing). When voluntary misuse is done, it ensures there is no benefit for the RCVs crew to roll backwards with footboard(s) in usable position. It will indirectly reduce the risks of falling from the footboard or crushing the operator.</p>			

(1) Essential health and safety requirement

Note: According to point 6.6 of the Guide of the implementation of directives based on the New Approach and the Global Approach, the notified bodies apply as general guidance this recommendation for use.

	CO-ORDINATION OF NOTIFIED BODIES Machinery Directive 2006/42/EC + amendments RECOMMENDATION FOR USE		CNB/M/08.001 Revision: 04 Language: EN
Number of pages: 1	Date: 23.06.1997	To be approved by:	Approved on:
Origin: VG8 Vehicles servicing lifts		<input checked="" type="checkbox"/> Vertical Group	12.04.2010
		<input checked="" type="checkbox"/> Horizontal Committee	13.12.1995
		To be endorsed by:	Endorsed on:
		<input checked="" type="checkbox"/> Machinery Expert Group	04.06.1996
Question related to: Directive 2006/42/EC	Article: -	EN/prEN: pr EN 1493	Other: -
Annex: -	EHSR (1): -	Normative clause: 5.6.5.6	Other clause: -
		CEN TC concerned: TC 98 WG 3	
Key words: Polyamide Nuts			
<p>Question:</p> <p>With regard to screw drives red brass or bronze are the most common materials for the load bearing nut and the safety nut as written in the comments of the German prevention rule VBG 14. However, some manufacturers intend to use polyamide for the load bearing nut. Some tests in our institute have shown that polyamide nuts can have the same or even a better tribological behaviour than bronze nuts, e.g. with regard to self-locking and self-retarding. Is it allowed to use polyamide nuts in vehicle lifts? Do the other NB's have any experiences with these nuts, especially when the lubricant is contaminated with dirt or particles (e.g. swarf)?</p>			
<p>Solution:</p> <p>Polyamide nuts may be used in vehicle lifts, provided that lifetime tests have been carried out. The technical should</p> <ul style="list-style-type: none"> • describe the conditions for this test which should include • carrying out min. 30000 load cycles (nominal load), which relates to a life time of 10 years. <p>A safety factor of 6 against breaking shall be used.</p>			

(1) Essential health and safety requirement

Note: According to point 6.6 of the Guide of the implementation of directives based on the New Approach and the Global Approach, the notified bodies apply as general guidance this recommendation for use.

	CO-ORDINATION OF NOTIFIED BODIES Machinery Directive 2006/42/EC + amendments RECOMMENDATION FOR USE		CNB/M/08.002 Revision: 04 Language: EN
Number of pages: 1 Origin: VG8 Vehicles servicing lifts	Date: 03.07.2023	To be approved by: <input checked="" type="checkbox"/> Vertical Group <input checked="" type="checkbox"/> Horizontal Committee To be endorsed by: <input checked="" type="checkbox"/> Machinery Expert Group	Approved on: 12.04.2010 09.12.1998 Endorsed on: 03.03.2000
Question related to: Directive 2006/42/EC Annex: -	Article: - EHSR (1): -	EN/prEN: - Normative clause: - CEN TC concerned: -	Other: - Other clause: -
Key words: EC Type Test			
Question: How do we proceed, when the EC-type test refers to a group of machines (vehicle lifts) with the same design features and merely different load-carrying capacities? Do we have to test each machine (vehicle lift) or is it sufficient to test the type with minimum and/or maximum bearing capacity?			
Solution: Each type of vehicle lift has to be tested and compliance with the ESR'S of MD has to be confirmed by the NB. The extent of test can be reduced in case of similar equipment by responsibility of the NB. (see also CNB/M/03.009)			

(1) Essential health and safety requirement

Note: According to point 6.6 of the Guide of the implementation of directives based on the New Approach and the Global Approach, the notified bodies apply as general guidance this recommendation for use.

	CO-ORDINATION OF NOTIFIED BODIES Machinery Directive 2006/42/EC + amendments RECOMMENDATION FOR USE		CNB/M/08.003 Revision: 05 Language: EN
Number of pages: 2 Origin: VG8 Vehicles servicing lifts	Date: 03.07.2023	To be approved by: <input checked="" type="checkbox"/> Vertical Group <input checked="" type="checkbox"/> Horizontal Committee To be endorsed by: <input checked="" type="checkbox"/> Machinery Expert Group	Approved on: 12.04.2010 09.12.1998 Endorsed on: 03.03.2000
Question related to: Directive 2006/42/EC Annex: -	Article: - EHSR (1): -	EN/prEN: EN ISO 12100-2:2003 Normative clause: - CEN TC concerned: -	Other: - Other clause: -
Key words: instruction handbook, check			
Question: Is it necessary within the EC-type test to examine the content of the instruction handbook in detail or is it sufficient to check the handbook only in a formal way e.g. with regard to chapter 6 of EN 12100-2:2003?			
Solution: Notified bodies shall examine the safety relevant content of the instruction handbook (content see EN 12100-2 clause 6). Details for vehicle lifts are e.g. (see next page).			

(1) Essential health and safety requirement

Note: According to point 6.6 of the Guide of the implementation of directives based on the New Approach and the Global Approach, the notified bodies apply as general guidance this recommendation for use.

Details for vehicle lifts (cont.)

- Information about the product:
 - name of manufacturer, importer or dealer,
 - type designation of product,
 - date of issue of the instruction manual, status,
 - address of manufacturer, address of authorized representative,
 - technical ratings of the vehicle lift (load, load distribution, height),
 - intended use (lifting of cars), inappropriate use (lifting of people), special applications
 - available equipment options (wheel free systems, alignment systems),
 - weight and dimensions,
 - special properties (e.g. Ex proof),
 - noise and other emissions.

- Information about installation:
 - limitations of environmental ambient conditions (temperature, humidity, water),
 - required floor conditions (strength, preparation),
 - electrical supply requirements (voltage, current, supply cable size, starting current, fusing),
 - hydraulic supply requirements (max. pressure, oil quality and amounts),
 - pneumatic supply requirements (max. pressure),
 - means the user has to provide (power system, mains switch, guards),
 - final checks.

- Information about the use
 - description of controls (raising, lowering),
 - description of safety devices (safety catch, levelling system, emergency stop, rope or chain failure),
 - adjustment procedures (if any),
 - emergency stop procedures, restarting.
 - operating modes (independent / common control), safety features in different operating modes,
 - protection against unauthorized use (use of key switches),
 - rules for handling of special conditions (after tripping of protective devices, emergency lowering)
 - warning of dangerous parts (high voltage, high pressure),
 - error handling procedures (tripping of fuses, desynchronisation),
 - charging of batteries (ventilation),
 - safety instructions (e.g. no persons under the lift during movement),
 - authorization for operating.

- Maintenance and repair
 - necessary spare parts,
 - service intervals,
 - special safety precautions during maintenance and repair,
 - safety inspections and tests.

- User information
 - parts lists (electrical, hydraulic, pneumatic),
 - schematics (electrical, hydraulic, pneumatic),
 - pictures, photos, exploded view

	CO-ORDINATION OF NOTIFIED BODIES Machinery Directive 2006/42/EC + amendments RECOMMENDATION FOR USE		CNB/M/08.008 Revision: 03 Language: EN
Number of pages: 1 Origin: VG8 Vehicles servicing lifts	Date: 25.10.1996	To be approved by: <input checked="" type="checkbox"/> Vertical Group <input checked="" type="checkbox"/> Horizontal Committee To be endorsed by: <input checked="" type="checkbox"/> Machinery Expert Group	Approved on: 12.04.2010 17.04.1996 Endorsed on: 08.06.1998
Question related to: Directive 2006/42/EC Annex: -	Article: - EHSR (1): -	EN/prEN: pr EN 1493 N12 Normative clause: - CEN TC concerned: TC 98 WG 3	Other: - Other clause: -
Key words: Auxiliary Lifting Systems			
Question: Safety requirements for auxiliary lifting systems installed on vehicle lifts: Are safety devices for preventing <ul style="list-style-type: none"> • desynchronisation of lifting and lowering, • inadvertent lowering in case of a failure in the lifting system also required for these systems?			
Solution: For auxiliary lifting systems on vehicle lifts the same safety devices are required as necessary for the vehicle tilts. The reason for that are hazards to be taken into consideration from <ul style="list-style-type: none"> • positioning the head and arms by manipulations in upper position of the lift • lifting vehicles without wheels in case of using auxiliary lifts. 			

(1) Essential health and safety requirement

Note: According to point 6.6 of the Guide of the implementation of directives based on the New Approach and the Global Approach, the notified bodies apply as general guidance this recommendation for use.

	CO-ORDINATION OF NOTIFIED BODIES Machinery Directive 2006/42/EC + amendments RECOMMENDATION FOR USE		CNB/M/08.015 Revision: 03 Language: EN
Number of pages: 1 Origin: VG8 Vehicles servicing lifts	Date: 13.11.2000	To be approved by: <input checked="" type="checkbox"/> Vertical Group <input checked="" type="checkbox"/> Horizontal Committee To be endorsed by: <input checked="" type="checkbox"/> Machinery Expert Group	Approved on: 12.04.2010 11.12.2003 Endorsed on: 01.07.2004
Question related to: Directive 2006/42/EC Annex: -	Article: - EHSR (1): -	EN/prEN: EN 1493:1998 Normative clause: 5.16.3 CEN TC concerned: TC 98 WG 3	Other: - Other clause: -
Key words: Rails, foot protectors, protection against pinching points			
Question: How shall foot protectors to be designed?			
Solution: The design shall take into account that a person may step on it in the ground position, without losing its safety function. It does not to be designed to withstand an obstruction when lowering.			

(1) Essential health and safety requirement

Note: According to point 6.6 of the Guide of the implementation of directives based on the New Approach and the Global Approach, the notified bodies apply as general guidance this recommendation for use.

	CO-ORDINATION OF NOTIFIED BODIES Machinery Directive 2006/42/EC + amendments RECOMMENDATION FOR USE		CNB/M/08.016 Revision: 03 Language: EN
Number of pages: 1	Date: 06.05.2002	To be approved by:	Approved on:
Origin: VG8 Vehicles servicing lifts		<input checked="" type="checkbox"/> Vertical Group	12.04.2010
		<input checked="" type="checkbox"/> Horizontal Committee	11.12.2003
		To be endorsed by:	Endorsed on:
		<input checked="" type="checkbox"/> Machinery Expert Group	01.07.2004
Question related to: Directive 2006/42/EC	Article: -	EN/prEN: EN 1493:1998	Other: -
Annex: -	EHSR (1): -	Normative clause: 5.6.4.2	Other clause: -
		CEN TC concerned: TC 98 WG 3	
Key words: Chassis supporting vehicle lift for road vehicles, load distribution			
Question: Is it acceptable to use load distribution plates and impose restriction on positioning of road vehicle on the lift (for example restriction on the vehicle direction) when lifting?			
Solution: NO. The calculations for a chassis supporting vehicle lift shall be carried out in the most unfavourable configuration, in order to meet the essential health and safety requirements of the Machinery Directive. For structural design purposes vehicle positioning on load carrying devices shall be considered in both directions. Restriction on the vehicle direction given in load distribution plates and in the instructions of the lifts for normal road vehicles do not meet the principles of safety integration of Machinery Directive. Restrictions may only be allowed for special vehicle lifts (e.g. for fork lift trucks, dumpers, rail bound vehicles etc. according to the clause 5.6.4.3 of EN 1493:1998+A1).			

(1) Essential health and safety requirement

Note: According to point 6.6 of the Guide of the implementation of directives based on the New Approach and the Global Approach, the notified bodies apply as general guidance this recommendation for use.

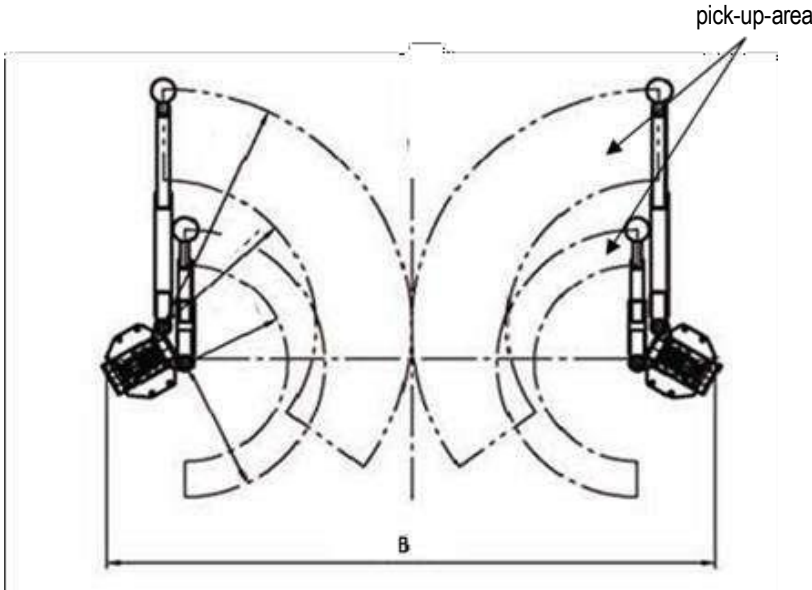
	<p>CO-ORDINATION OF NOTIFIED BODIES Machinery Directive 2006/42/EC + amendments</p> <p>RECOMMENDATION FOR USE</p>		<p>CNB/M/08.018 Revision: 05 Language: EN</p>
<p>Number of pages: 2 Origin: VG8 Vehicles servicing lifts</p>	<p>Date: 03.07.2023</p>	<p>To be approved by: <input checked="" type="checkbox"/> Vertical Group <input checked="" type="checkbox"/> Horizontal Committee To be endorsed by: <input checked="" type="checkbox"/> Machinery Expert Group</p>	<p>Approved on: 25.04.2013 26.06.2013 Endorsed on: 22.11.2013</p>
<p>Question related to: Directive 2006/42/EC Annex: I</p>	<p>Article: - EHSR (1): 1.1.2.</p>	<p>EN/prEN: EN 1493:2010 Normative clause: 5.7.4.3. a) and b) CEN TC concerned: CEN TC 98</p>	<p>Other: - Other clause: -</p>
<p>Key words: Load distribution on two post lifts with load-bearing arms</p>			
<p>Question:</p> <p>Is it necessary for two post lifts, where both arms of one column could swing in the same direction, to consider this position for the stability and strengths calculation? Has the manufacture take into account such a manner of use as normal use ore as foreseeable misuse in accordance with the machinery directive section 1.1.2. annex 1.</p>			
<p>Solution:</p> <p>The standard requires that the long arms must be in the maximum telescoped position with a width of 1 m of the pick-up points. The short arms should be "in the position which gives the worst condition". Normally, vehicles are raised so that the center of gravity is close to the connecting line between the two lifting columns. But there are many vehicle servicing lifts where it is possible to raise a vehicle with all four arms pivoted in the same direction (see figure 1). Especially at asymmetric two post lifts or lifts with double swing arms, it is possible, to reach such a position and to lift vehicles.</p> <div style="text-align: center;">  </div> <p>Figure 1 asymmetric post lift</p>			

Do to the position centre of gravity of the load the bending moment is significantly larger than during pick up a vehicle in a central position where the arms of the post are pivoted in different directions. Due to the very different design of the mounting points of the various vehicles and the differences in design of the lifts, it is very difficult to assess which vehicles can be lifted in detail. The practice shows, that especially smaller cars can be lifted in such a position.

Solution:

The answer to both questions is yes. Since it is possible to lift cars in this position and the standard requires in 5.7.4.3 a) and b):

"On vehicle lifts with carrying arms the rated load shall be distributed on the four corners of a rectangle with the dimensions of 100 cm (width) with the maximum load at the maximum length of the longest arm and the short arm in the position which gives the worst condition."

The manufacturer has to consider this position in the safety design of its vehicle lift.

VG 8 sees two basic approaches:

- prevention of lifting in such a position (for example, by limiting the swiveling range of the arms, a safety device prevents a lifting movement in this position or a load moment limiting device)
- sufficient stability and attachment of the vehicle lift, so that the rated load can be lifted safely also in this position

Calculation - permissible stresses

The normal values of permissible stresses are given in Annex A of EN 1493:2010. A safety factor of 1,5 must be achieved.

In view of the situation, that in this position usually only smaller vehicles can be lifted, which do not reach the rated load of the lift, it is acceptable in that case to reduce the safety factors for the calculation of stability and strength.

Under the most unfavorable loading conditions - all four arms on one side of the lift, long arms in maximum ejection position, pick up points in wheel track direction 1m distance, pick up points in wheelbase direction 1m distance, rated load according section 5.7.4.3 a) and b) at least a minimum safety factor of 1,2 is acceptable. The vehicle lift has to be sufficiently strong and stable during movement of the load.

In that case an additional warning label on the lift and a appropriate note in the user manual shall include the prohibition of the use in this position

In the position distance in wheelbase direction 1,4m (normative rectangle) a safety factor of 1,5 must be kept.

If the use of the lift in this way (four arms in one direction) is approved by the manufacturer, a reduction of lift capacity in this position by labelling is not allowed.

(1) Essential health and safety requirement

Note: According to point 6.6 of the Guide of the implementation of directives based on the New Approach and the Global Approach, the notified bodies apply as general guidance this recommendation for use.

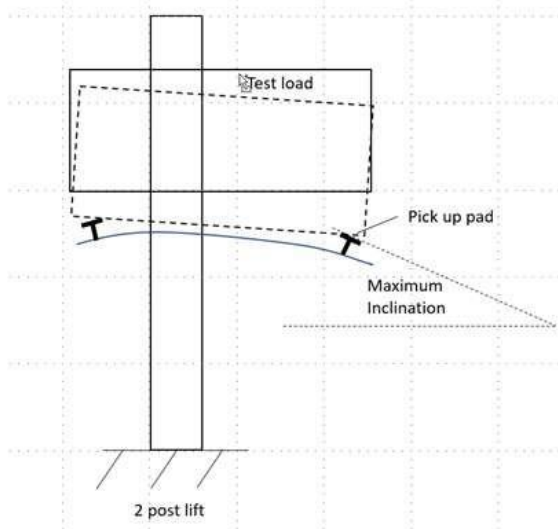
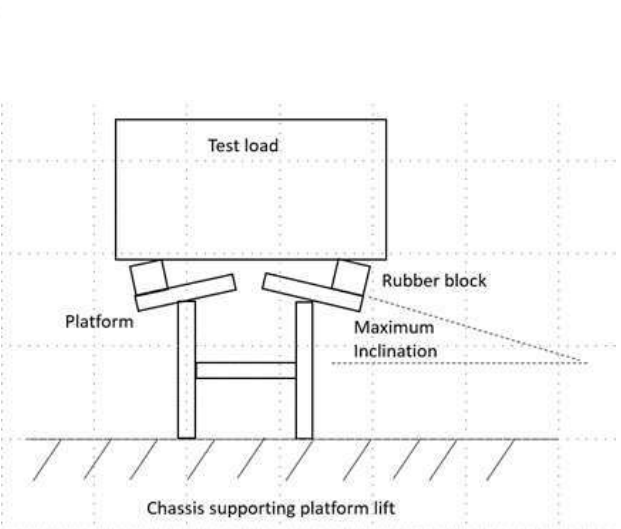
	CO-ORDINATION OF NOTIFIED BODIES Machinery Directive 2006/42/EC + amendments RECOMMENDATION FOR USE		CNB/M/08.023 Revision: 03 Language: EN
Number of pages: 1 Origin: VG8 Vehicles servicing lifts	Date: 03.07.2023	To be approved by: <input checked="" type="checkbox"/> Vertical Group <input checked="" type="checkbox"/> Horizontal Committee To be endorsed by: <input checked="" type="checkbox"/> Machinery Expert Group	Approved on: 08.06.2021 16.12.2021 Endorsed on: 23.03.2023
Question related to: Directive 2006/42/EC Annex: -	Article: - EHSR (1): -	EN/prEN: 1493:2010 Normative clause: 6.1.5.2 CEN TC concerned: -	Other: - Other clause: -
Key words: Maximum inclination of pickup plates and pads			
Question: What is the maximum acceptable inclination to horizontal for the surface of pick up pads or plates of chassis supporting vehicle servicing lifts during the load test according to section 6.1.5.4			
Solution: The maximum angle, measured with an instrument with an accuracy of at least +/- 0,5 degrees, shall be 5 degrees to horizontal. After removal of the test load, no permanent deformation must be visible. Test conditions. <ul style="list-style-type: none"> - Lift the test load with load supporting points in all positions which create maximum stress in any load bearing part. - Rated load as test load, distributed according to 5.7.4.3 - Raise load until fully supported on pick up pads or surfaces and maintain in position for one minute - Inclination to be measured whilst load remains on lift <div style="display: flex; justify-content: space-around; align-items: flex-end;"> <div data-bbox="239 1456 798 1982" style="text-align: center;">  <p>2 post lift</p> </div> <div data-bbox="813 1456 1436 1982" style="text-align: center;">  <p>Chassis supporting platform lift</p> </div> </div>			

(1) Essential health and safety requirement

Note: According to point 6.6 of the Guide of the implementation of directives based on the New Approach and the Global Approach, the notified bodies apply as general guidance this recommendation for use.

	CO-ORDINATION OF NOTIFIED BODIES Machinery Directive 2006/42/EC + amendments RECOMMENDATION FOR USE		CNB/M/08.024 Revision: 04 Language: EN
Number of pages: 1 Origin: VG8 Vehicles servicing lifts	Date: 03.07.2023	To be approved by: <input checked="" type="checkbox"/> Vertical Group <input checked="" type="checkbox"/> Horizontal Committee To be endorsed by: <input checked="" type="checkbox"/> Machinery Expert Group	Approved on: 21.12.2021 14.06.2022 Endorsed on: 23.03.2023
Question related to: Directive 2006/42/EC Annex: -	Article: - EHSR (1): -	EN/prEN: 1493:2010 Normative clause: 6.1.3 CEN TC concerned: -	Other: - Other clause: -
Key words: Welding examination			
Question: How should a Body Examiner validate conformity with EN 1493:2010 6.1.3 Manufacturing check c) welding has been performed according to the drawings and 2006/42/EC Annex I 1.2.3 Risk of break-up during operation and 4.1.2.3. Mechanical strength for lifting equipment.			
Solution: Mechanical drawings for equipment must include clear and comprehensive indication of the welding to be used for fabrication. This must include specification of welder qualifications, procedures, material and equipment to be used, either specifically on a drawing or as a general specification for manufacture The Notified Body Examiner must visually compare a representative sample of the welding on the equipment being examined with that specified in the drawing. Based on informal visual inspection, where the Notified Body examiner has reason to suspect that welding is not of good quality, they must request credible NDT reports on welds which concern them. After testing at 150% proof load, NB examiners must visually examine welds likely to have been subjected to higher stresses and check for evidence of deformation or cracking. Again, if the examiner has concerns, they must request credible NDT reports for selected welds.			

(1) Essential health and safety requirement

Note: According to point 6.6 of the Guide of the implementation of directives based on the New Approach and the Global Approach, the notified bodies apply as general guidance this recommendation for use.

	CO-ORDINATION OF NOTIFIED BODIES Machinery Directive 2006/42/EC + amendments RECOMMENDATION FOR USE		CNB/M/08.025 Revision: 03 Language: EN
Number of pages: 1 Origin: VG8 Vehicles servicing lifts	Date: 03.07.2023	To be approved by: <input checked="" type="checkbox"/> Vertical Group <input checked="" type="checkbox"/> Horizontal Committee To be endorsed by: <input checked="" type="checkbox"/> Machinery Expert Group	Approved on: 31.05.2022 14.06.2022 Endorsed on: 23.03.2023
Question related to: Directive 2006/42/EC Annex: -	Article: - EHSR (1): -	EN/prEN: 1493:2010 Normative clause: 6.1.2 CEN TC concerned: -	Other: - Other clause: -
Key words: Structural Calculations			
Question: <p>How should a Notified Body Examiner validate conformity with EN 1493:2010 6.1.2 Design check.</p> <p>The documents shall give all necessary information to enable: f) the structural calculations to be checked; and 2006/42/EC Annex I 1.3.2. Risk of break-up during operation and 4.1.2.3. Mechanical strength for lifting equipment</p>			
Solution: <p>The Notified Body examiner shall check that:</p> <ul style="list-style-type: none"> - structural calculations are available in the Technical File - the calculations have been carried out competently - the calculations demonstrate that all the relevant loadings mentioned in EN 1493:2010 5.7 Structural Design of the Load Supporting Structure have been considered - the calculations demonstrate that under worst case loading, no parts exceed the permissible stresses in EN 1493:2010 Annex A. 			

(1) Essential health and safety requirement

Note: According to point 6.6 of the Guide of the implementation of directives based on the New Approach and the Global Approach, the notified bodies apply as general guidance this recommendation for use.

	CO-ORDINATION OF NOTIFIED BODIES Machinery Directive 2006/42/EC + Amendment RECOMMENDATION FOR USE	CNB/M/09.206 Revision 04 Language: E
Date of first stage: 02/04/2003	To be approved by:	Approved on:
Origin: VG9 Lifting persons device (LPD)	<input checked="" type="checkbox"/> Vertical Group <input checked="" type="checkbox"/> Horizontal Committee To be endorsed by: <input checked="" type="checkbox"/> Machinery Working Group....	13/04/2010 11/12/2003 Endorsed on: 14/03/2007
Question related to: Directive 2006/42/EC Article: 12 (3) Annex: IX ESR (1):	EN/prEN: Clause: CEN TC concerned:	Other: Other clause:
Key words: Lifting Persons Device (LPD), Suspended Access Equipment, modular construction, certification		
Question: Is it possible to certify the modules of a Suspended Access Equipment separately, provided the limits of application and conditions of use are clearly laid down?		
<p>Solution:</p> <p>NO "Temporary Suspended Platforms" designed on a modular basis in order to allow actual installations to be easily configured according to the needs on site can only be certified as a complete machine. It's up to the negotiation between the applicant and the NB to define which configuration of the machine represents in the best way all possibilities and which is then subject of the type examination procedure. The manufacturers instructions, the examination of which is part of the EC type-examination, must contain in detail descriptions which modules can be combined and how that has to be done to allow different configurations. A positive passing of the EC type-examination then leads to <u>one</u> certificate of the tested configuration including all possible combinations, described in the instructions. A modification of a module/component or the addition of a new one requires information from the manufacturer to the NB having issued the certificate and which has to decide, whether this modification needs renewal of the certificate or not.</p> <p>The idea, to regard all modules/components as interchangeable equipment and certify them independently, was not taken as an appropriate method of certification for these wishes of manufacturers to be more flexible.</p> <p>Adaptation procedure: FORMAL ADAPTATION IN CONFORMITY WITH DIRECTIVE 2006/42/EC</p>		

(1) Essential safety requirement

Note: According to point 6.6 of the Guide of the implementation of directives based on the New Approach and the Global Approach, the notified bodies apply as general guidance this recommendation for use.

	CO-ORDINATION OF NOTIFIED BODIES Machinery Directive 2006/42/EC + Amendment RECOMMENDATION FOR USE	CNB/M/09.207 Revision 10 Language: E
Date of first stage: 17/07/1998	To be approved by:	Approved on:
Origin: VG9 Lifting persons device (LPD)	<input checked="" type="checkbox"/> Vertical Group	13/04/2010
	<input checked="" type="checkbox"/> Horizontal Committee	26/11/2009
Question related to: Directive 2006/42/EC Article: Annex: IV ESR (1):	To be endorsed by:	Endorsed on:
	<input checked="" type="checkbox"/> Machinery Working Group....	26/05/2010
	EN/prEN: Other: Clause: Other clause: CEN TC concerned:	
Key words: Type-examination		
Question: What is the range of an EC type-examination for a machine, where the lifting of persons is not the primary function?		
<p>Solution:</p> <p>In the minutes of the 167 1st meeting of the Council (internal market) held on 1993-06-14 it is stated:</p> <p>“The Council and the Commission agree that the type examination of a device for the lifting of persons shall be limited to the lifting device itself and not to the complete machine which includes the lifting device.”</p> <p>VG9 understands this statement as follows:</p> <ul style="list-style-type: none"> • In the case of interchangeable equipment the handling is explained in the Commission document: “Interchangeable equipment for lifting persons and equipment used with machinery designed for lifting goods for the purpose of lifting persons” available on the EUROPA website: http://ec.europa.eu/enterprise/sectors/mechanical/documents/guidance/machinery/index_en.htm • In case of an integral part of a machine, besides the examination and tests of the lifting appliance itself the EC type-examination has to include also those functions, components or aspects of the whole machine, the operation or malfunction of which affect the safety of lifted persons. 		

(1) Essential safety requirement

Note: According to point 6.6 of the Guide of the implementation of directives based on the New Approach and the Global Approach, the notified bodies apply as general guidance this recommendation for use.

	CO-ORDINATION OF NOTIFIED BODIES Machinery Directive 2006/42/EC + Amendment RECOMMENDATION FOR USE	CNB/M/09.209 Revision 04 Language: E
Date of first stage: 02/04/2003	To be approved by:	
Origin: VG9 Lifting persons device (LPD)	<input checked="" type="checkbox"/> Vertical Group <input checked="" type="checkbox"/> Horizontal Committee	Approved on: 13/04/2010 11/12/2003
Question related to: Directive 2006/42/EC Article: Annex: VI ESR (1):		To be endorsed by: <input checked="" type="checkbox"/> Machinery Working Group....
Key words: EC type-examination, work platform, loader crane		EN/prEN: Other: Clause: Other clause: CEN TC concerned:
Question: What is the scope of a EC type-examination of a work platform installed on the boom of a loader crane on a vehicle?		
<p>Solution:</p> <p>In this case the notified body shall check conformity <u>of the entire device</u> for lifting persons constituted by the work platform, the loader crane and the supporting chassis with the Essential Health and Safety Requirements (EHSRs) of the directive 2006/42/EC (in particular: resistance, stability, control of the placing of the stabilisers).</p> <p>If the platform is designed for use on several models of cranes the EC type-examination certificate shall list the models concerned. The certificate shall also state the models of supporting chassis on which the conformity of the Lifting Persons device has been checked.</p> <p>Adaptation procedure: FORMAL ADAPTATION IN CONFORMITY WITH DIRECTIVE 2006/42/EC</p>		

(1) Essential safety requirement

Note: According to point 6.6 of the Guide of the implementation of directives based on the New Approach and the Global Approach, the notified bodies apply as general guidance this recommendation for use.

	CO-ORDINATION OF NOTIFIED BODIES Machinery Directive 2006/42/EC + Amendment RECOMMENDATION FOR USE	CNB/M/09.305 Revision 06 Language: E
Date of first stage: 06/03/1998	To be approved by:	Approved on:
Origin: VG9 Lifting persons device (LPD)	<input checked="" type="checkbox"/> Vertical Group <input checked="" type="checkbox"/> Horizontal Committee To be endorsed by: <input checked="" type="checkbox"/> Machinery Working Group....	13/04/2010 11/06/1998 Endorsed on: 09/04/2001
Question related to: Directive 2006/42/EC Annex: I	Article: ESR (1): 6.3.2 EN/prEN:EN 280:2001+A2:2008 Clause: 5.6.1 CEN TC concerned:	Other: Other clause:
Key words: Mobile Elevated Workplatform (MWE), levelling system		
Question: Is in addition to the levelling system (mechanical or hydraulic) a manual adjustment of the platform level acceptable, which may cause a platform level or more than 5° ?		
<p>Solution: Yes, provided that in a master-slave levelling system and in an independent hydraulic or mechanical levelling system a manual adjustment is speed limited to 0,5°/s.</p> <p>Adaptation procedure: FORMAL ADAPTATION IN CONFORMITY WITH DIRECTIVE 2006/42/EC</p>		

(1) Essential safety requirement

Note: According to point 6.6 of the Guide of the implementation of directives based on the New Approach and the Global Approach, the notified bodies apply as general guidance this recommendation for use.

	CO-ORDINATION OF NOTIFIED BODIES Machinery Directive 2006/42/EC + Amendment RECOMMENDATION FOR USE	CNB/M/09.307 Revision 04 Language: E										
Date of first stage: 28/04/1999	To be approved by: <table style="width: 100%; border: none;"> <tr> <td style="width: 50%; border: none;">Approved on:</td> <td style="width: 50%; border: none;"></td> </tr> <tr> <td style="border: none;"><input checked="" type="checkbox"/> Vertical Group</td> <td style="border: none; text-align: right;">13/04/2010</td> </tr> <tr> <td style="border: none;"><input checked="" type="checkbox"/> Horizontal Committee</td> <td style="border: none; text-align: right;">24/05/2000</td> </tr> <tr> <td style="border: none;">To be endorsed by:</td> <td style="border: none;">Endorsed on:</td> </tr> <tr> <td style="border: none;"><input checked="" type="checkbox"/> Machinery Working Group....</td> <td style="border: none; text-align: right;">09/04/2001</td> </tr> </table>		Approved on:		<input checked="" type="checkbox"/> Vertical Group	13/04/2010	<input checked="" type="checkbox"/> Horizontal Committee	24/05/2000	To be endorsed by:	Endorsed on:	<input checked="" type="checkbox"/> Machinery Working Group....	09/04/2001
Approved on:												
<input checked="" type="checkbox"/> Vertical Group	13/04/2010											
<input checked="" type="checkbox"/> Horizontal Committee	24/05/2000											
To be endorsed by:	Endorsed on:											
<input checked="" type="checkbox"/> Machinery Working Group....	09/04/2001											
Origin: VG9 Lifting persons device (LPD)												
Question related to: Directive 2006/42/EC Article: Annex: I ESR (1): 6.3.1	EN/prEN: Clause: CEN TC concerned:	Other: Other clause:										
Key words: Lifting Persons Device, safety gear												
Question: Do lifting persons device with positive driving units need safety gears ?												
<p>Solution:</p> <p>It is a general rule, that uncontrolled movements of the load carrying unit of LPD due to wear or failure in the driving unit need to be avoided. Appropriate means are overspeed governed safety gears, rupture valves, lock valves, redundant drive units, safety nuts etc. Standards for LPD address these means. Design of a driving unit taking into account factors to increase the loads and forces to be taken by them is not regarded as appropriate measure against uncontrolled movement.</p> <p>Adaptation procedure: FORMAL ADAPTATION IN CONFORMITY WITH DIRECTIVE 2006/42/EC</p>												

(1) Essential safety requirement

Note: According to point 6.6 of the Guide of the implementation of directives based on the New Approach and the Global Approach, the notified bodies apply as general guidance this recommendation for use.

	CO-ORDINATION OF NOTIFIED BODIES Machinery Directive 2006/42/EC + Amendment RECOMMENDATION FOR USE	CNB/M/09.309 Revision 04 Language: E
Date of first stage: 28/04/1999 Origin: VG9 Lifting persons device (LPD)	To be approved by: <input checked="" type="checkbox"/> Vertical Group <input checked="" type="checkbox"/> Horizontal Committee To be endorsed by: <input checked="" type="checkbox"/> Machinery Working Group....	Approved on: 13/04/2010 24/05/2000 Endorsed on: 09/04/2001
Question related to: Directive 2006/42/EC Annex: I, IV	Article: ESR (1): 1.1.2, 1.6.2, 6.3.2	EN/prEN:EN 280:2001+A2:2008 Clause: 5.6.3 CEN TC concerned: Other: Other clause:
Key words: Mobile Elevated Work Platform, MEWP, access, movable guard, abnormal use		
Question: Is it acceptable to use manually liftable bars returning into the safeguarding position by gravity as means as protection at the access to work platforms ?		
Solution: Yes. The possibility of deliberate fixing in the open position of protection means at the access to work platforms needs not to be regarded as abnormal use which has to be prevented by construction.		
<p>Adaptation procedure: FORMAL ADAPTATION IN CONFORMITY WITH DIRECTIVE 2006/42/EC</p>		

(1) Essential safety requirement

Note: According to point 6.6 of the Guide of the implementation of directives based on the New Approach and the Global Approach, the notified bodies apply as general guidance this recommendation for use.

	<p>CO-ORDINATION OF NOTIFIED BODIES Machinery Directive 2006/42/EC + Amendment</p> <p>RECOMMENDATION FOR USE</p>	<p>CNB/M/09.310 Revision 05</p> <p>Language: E</p>
<p>Date of first stage: 28/04/1999</p>	<p>To be approved by:</p>	<p>Approved on:</p>
<p>Origin: VG9 Lifting persons device (LPD)</p>	<p><input checked="" type="checkbox"/> Vertical Group</p> <p><input checked="" type="checkbox"/> Horizontal Committee</p> <p>To be endorsed by:</p> <p><input checked="" type="checkbox"/> Machinery Working Group....</p>	<p>13/04/2010</p> <p>24/05/2000</p> <p>Endorsed on:</p> <p>09/04/2001</p>
<p>Question related to: Directive 2006/42/EC Article: Annex: I ESR (1): 4.1.2.4, 6.1.2</p>	<p>EN/prEN: Clause: CEN TC concerned:</p>	<p>Other: Other clause:</p>
<p>Key words: Man rider winches, one rope suspension</p>		
<p>Question: Is it acceptable to use one-rope suspension in person lifting device?</p>		
<p>Solution:</p> <p>At silo access equipment and man rider winches doubled suspension elements create hazards which are not acceptable, e. g. twisting, entanglement, etc. Therefore on these equipment one-rope suspension is acceptable provided</p> <ol style="list-style-type: none"> 1. steel wire ropes with at least 10mm diameter are used in order to have a certain resistance against mechanical damage, 2. the factor of utilisation is at least 10, 3. the design of the rope drive is in accordance with prEN 280:1998, Annex C, with the load collective “heavy”, 4. there are protective means preventing derailing of the rope from the drum or any pulley, 5. the winding up on the drum is governed by a spooling device, 6. there is a slack-rope device 7. the rope is suitably protected against corrosion and other environmental influences and 8. the instructions for use are clearly stating <ul style="list-style-type: none"> • the need of periodical inspections of the device • the need of inspection of the rope before starting work where the winch was not used for a longer period of time taking into account the provisions laid down in the EU-Directive 2009/104/EC and environmental conditions and • criteria for the replacement of the rope. <p>These provisions do not cover all aspects of these kind of LPD. Other aspects have to be subject of a risk assessment in accordance with the Machinery Directive.</p> <p>Adaptation procedure: FORMAL ADAPTATION IN CONFORMITY WITH DIRECTIVE 2006/42/EC</p>		

(1) Essential safety requirement

Note: According to point 6.6 of the Guide of the implementation of directives based on the New Approach and the Global Approach, the notified bodies apply as general guidance this recommendation for use.

	CO-ORDINATION OF NOTIFIED BODIES Machinery Directive 2006/42/EC + amendments RECOMMENDATION FOR USE		CNB/M/09.318 Revision: 07 Language: EN
Number of pages: 2 Origin: VG9 Lifting persons device (LPD)	Date: 03.07.2023	To be approved by: <input checked="" type="checkbox"/> Vertical Group <input checked="" type="checkbox"/> Horizontal Committee To be endorsed by: <input checked="" type="checkbox"/> Machinery Expert Group	Approved on: 12.06.2015 29.06.2016 Endorsed on: 23.03.2023
Question related to: Directive 2006/42/EC Annex: I	Article: - EHSR (1): -	EN/prEN: - Normative clause: - CEN TC concerned: -	Other: - Other clause: -
Key words: crushing hazards, ram frame.			
Question: Which specific requirements apply for service lifts used in wind turbines?			
Solution: <p>Scope and definition: A wind turbine is a machine in the scope of the directive 2006/42/EC because it contains moving parts fitted with a drive system (rotating of the yaw-system and/or rotor blades). When the wind turbine is equipped with a lift, the lifting equipment, including the landings and suspension, are subject to annex IV.17. A lift in a wind turbine is not only used for accessing the landings but also for other purposes like maintenance and inspections.</p> <p>Communication system: As a minimum, in view of its use in remote locations, a two way communication system has to be prescribed during normal use as well as during emergency operations.</p> <p>Carrier: Due to the lack of operating space (crushing and shearing hazards may occur when there is no opening distance of minimal 0.5 m is feasible) and for the protection against falling objects, usually a full enclosure of the carrier is necessary.</p> <p>The carrier must be equipped with an emergency stop.</p> <p>Opening carrier door(s) between landings: According to the requirements of Directive 2006/42/EG chapter 6.4.1 „...The door(s) must remain closed when the carrier stops between landings and where there is a risk of falling from the carrier...“, the opening of the carrier door(s) between the landings is not permitted and therefore a guard locking device preventing the opening of the door(s) until the carrier reaches a landing, is necessary.</p> <p>The carrier door must be equipped with a device which prevents movement of the carrier in case the door is in an open position.</p> <p>In practice, stopping between landings and opening of the carrier door may be required for purposes like maintenance. In that case, the following requirements exist:</p> <ul style="list-style-type: none"> • as soon as the carrier door is opened (by operating an additional separate handling device which is not used during normal operation of the lift and unlocks the carrier door lock) travelling of the carrier shall be stopped as long as the carrier door is open. This mechanism must not be easily accessible and be provided with a marking • when the carrier door is opened, prevention of falling of persons out of the carrier is required and leaving and entering are not allowed excluding during rescue operations. <p>In view of the use in remote locations, the opening of the carrier door for rescue operations shall be possible from both the in- and outside of the carrier.</p>			

Solution continued:

Protection of persons in the travel zone:

Crushing and shearing hazards are relevant when the distance between carrier and the rescue ladder is $\leq 0,5\text{m}$. When there is the possibility of hazardous contact between the moving carrier and persons on the ladder and at the landing gates, safeguarding at the floor and roof of the carrier must be present. The performance level shall be according to EN ISO 13849-1. Following the path S2-F1-P2, the result will be PL=d.

If the distance between carrier and the rescue ladder is more than 0.5 m, the safeguards can be used to protect the persons at the landings. When the full height landing gate is changed into a reduced height landing gate with minimum height of 1.1 m, the performance level shall be according to EN ISO 13849-1. Following the path S2-F1-P1 the result will be PL=c.

Landings and landing gates:

Landings are places for entering or leaving the carrier. This can be at the top or the bottom and at intermediate stops of the travel zone.

If the distance between the carrier and the landing gate is smaller than 0.5 m, a full height landing gate is required to prevent shearing and crushing hazards. If the distance between the carrier and the landing gate is smaller than 0.5 m, a reduced height landing gate (minimum height 1.1m) is allowed if the carrier is safeguarded at the top and bottom and has a flat surface. In this case, the performance level shall be according to EN ISO 13849-1. Following the path S2-F1-P1 the result will be PL=c.

The distance from the landing gates to the landing sill must be $\leq 0.15\text{ m}$ or else a safety device which detect and protect persons/obstacles must be present.

Interlocking of landing gates:

The risk assessment for the landing gates must cover the intended access to the carrier as well as the intended access to a ladder (e. g. for rescue operations):

- The landing door can be opened by a primary mechanism (bar/catch) if the carrier is present. The landing door cannot be opened by primary mechanism when the carrier is absent. The position of the carrier at the landing shall be detected making sure the carrier is in the correct travel zone for the opening of the door(s).
- The landing door can be opened when, in case of a rescue operation, the operator wants to use the ladder by operating an additional mechanism – e. g. second bar – which is not used during normal operating the lift; this feature shall be considered in the risk assessment. This additional opening mechanism is only necessary for opening the landing door when the carrier is not present at the landing. This mechanism may not to be easily accessible and be provided with a marking

Rescue conception:

The manufacturer of lifting equipment for the use by persons within wind turbines shall ensure that a contingency plan for rescue is available. The following points shall be considered:

- the person that has to be rescued is not able to assist during rescue (e.g. unconscious),
- adequate anchoring devices for the rescue teams in and on the carrier - EN 795,
- changing positions from the carrier to the ladder shall be possible in a safe way,
- ergonomic solutions shall be preferred,
- a carrier shall have a device for lowering the carrier in case of emergency.

(1) Essential health and safety requirement

Note: According to point 6.6 of the Guide of the implementation of directives based on the New Approach and the Global Approach, the notified bodies apply as general guidance this recommendation for use.

	<p>CO-ORDINATION OF NOTIFIED BODIES Machinery Directive 2006/42/EC + Amendment</p> <p>RECOMMENDATION FOR USE</p>	<p>CNB/M/09.401 Revision 08</p> <p>Language: E</p>
Date of first stage: 02/04/2003	To be approved by:	Approved on:
Origin: VG9 Lifting persons device (LPD)	<input checked="" type="checkbox"/> Vertical Group <input checked="" type="checkbox"/> Horizontal Committee	13/04/2010 11/12/2003
	To be endorsed by:	Endorsed on:
	<input checked="" type="checkbox"/> Machinery Working Group....	01/07/2004
Question related to: Directive 2006/42/EC Article:	EN/prEN:EN 280:2001+A2:2008 Other:	
Annex: I ESR (1): 1.2.4	Clause: 5.7.5 Other clause:	
CEN TC concerned: TC 98 WG 1		
Key words: MEWP, control devices, emergency stop, override		
Question: Is it allowed that a MEWP is equipped with a control at the base or ground level, which functions as an override for the emergency stop control situated on the work platform for the reason of rescuing of injured or incapacitated operators?		
<p>Solution:</p> <p>CEN/TC 98/WG 1 has studied the situation in its meeting 05.96. It was felt, that the trapping of a person in the work platform can happen due to different reasons, e.g. plucking out the energy supply, actuating the emergency control device, etc. The result in these cases is an unpleasant or awkward situation but not a direct risk to the persons. Therefore a need to override the emergency stop device at the control panel cannot be seen. The standard EN 280:2001+A2:2008 states in its foreword that it is assumed that persons on the work platform in case of power supply failure are not incapacitated and can assist in the operation of the overriding emergency device.</p> <p>Nevertheless there may be situations where the operator is incapacitated and the platform emergency stop pressed. In this situation the overriding emergency device may be too slow to recover the operator from the ground especially for high MEWPs. Therefore the need of an overriding cannot be ignored. Any overriding of the emergency stop control at the work platform of a MEWP shall require a deliberate action on a device being a safety device, independent from the selection control device and protected against unauthorised use.</p> <p>Emergency stop overriding shall not be possible on MEWPs which are equipped with a mode selection device acc. to Machinery Directive 2006/42/EC Annex I section 1.2.5 to bypass safety functions.</p> <p>Adaptation procedure: FORMAL ADAPTATION IN CONFORMITY WITH DIRECTIVE 2006/42/EC</p>		

(1) Essential safety requirement

Note: According to point 6.6 of the Guide of the implementation of directives based on the New Approach and the Global Approach, the notified bodies apply as general guidance this recommendation for use.

	<p>CO-ORDINATION OF NOTIFIED BODIES Machinery Directive 2006/42/EC + Amendment</p> <p>RECOMMENDATION FOR USE</p>	<p>CNB/M/09.501 Revision 05</p> <p>Language: E</p>
<p>Date of first stage: 28/04/1999</p>	<p>To be approved by:</p> <p><input checked="" type="checkbox"/> Vertical Group</p> <p><input checked="" type="checkbox"/> Horizontal Committee</p>	<p>Approved on:</p> <p>13/04/2010</p> <p>24/05/2000</p>
<p>Origin: VG9 Lifting persons device (LPD)</p>	<p>To be endorsed by:</p> <p><input checked="" type="checkbox"/> Machinery Working Group....</p>	<p>Endorsed on:</p> <p>09/04/2001</p>
<p>Question related to: Directive 2006/42/EC Article:</p> <p>Annex: I ESR (1): 1.5.10, 1.5.11</p>	<p>EN/prEN:</p> <p>Clause:</p> <p>CEN TC concerned:</p>	<p>Other:</p> <p>Other clause:</p>
<p>Key words: Radiation, EC-type examination, EMC directive</p>		
<p>Question: Does EMC directive cover all aspects of radiation addressed in 1.5.10 and 1.5.11 of Annex I Machinery directive?</p>		
<p>Solution:</p> <p>The provisions of the EMC-Directive do not cover all aspects of radiation addressed in 1.5.10 and 1.5.11.</p> <p>Especially regarding immunity of controls of LPD the following aspects need to be taken into consideration during type-examination:</p> <ol style="list-style-type: none"> 1. Light barriers shall not be influenced by light from the environment (sun, artificial light), 2. UV-radiation has influence on components made of plastic, 3. Laser beams can be dangerous for persons in the environment of the machine, 4. Sensors used as warning devices related to distances may be made inoperable, 5. Radio controls used in the environment may cause uncontrolled movements, 6. Ionised radiation may occur in case of fire, 7. Intended radiation like from mobile phones may cause malfunctions. <p>see also data sheet CNB/M/00.502</p> <p>Adaptation procedure: FORMAL ADAPTATION IN CONFORMITY WITH DIRECTIVE 2006/42/EC</p>		

(1) Essential safety requirement

Note: According to point 6.6 of the Guide of the implementation of directives based on the New Approach and the Global Approach, the notified bodies apply as general guidance this recommendation for use.

	CO-ORDINATION OF NOTIFIED BODIES Machinery Directive 2006/42/EC + amendments RECOMMENDATION FOR USE		CNB/M/09.502 Revision: 02 Language: EN
Number of pages: 1	Date: 03.07.2023	To be approved by:	Approved on:
Origin: VG9 Lifting persons device (LPD)		<input checked="" type="checkbox"/> Vertical Group	01.06.2015
		<input checked="" type="checkbox"/> Horizontal Committee	29.06.2016
		To be endorsed by:	Endorsed on:
		<input checked="" type="checkbox"/> Machinery Expert Group	23.03.2023
Question related to: Directive 2006/42/EC	Article: -	EN/prEN: a) EN 1808	Other: -
Annex: II	EHSR (1): 1.3.2 Risk of break-up in operation 6.1.1 Mechanical Strength	Normative clause: -	Other clause: -
Key words: lifting platforms, lifts, gripping device/safety gear, tripping device / overspeed governor, safety device, lifting persons			
<p>Question:</p> <p>Safety devices in machinery for lifting persons can consist of components which may be affected by wear. For example a safety gear triggered by an overspeed governor. When wear of a component can lead to a complete loss of functioning of the safety device, extra measures are necessary. The manufacturers usually specify a safe life period for these components.</p> <p>The relevant standard for this type of machine (EN1808:2015) has no additional requirements for testing and evaluation of safety relevant components affected by wear. Also this standard demands no determination of a lifetime of safety relevant components in the case these components are affected by wear.</p> <p>Is it necessary to verify during a type examination the prescribed life time by the manufacture and what are the conditions?</p>			
<p>Solution:</p> <p>The claimed lifetime of all safety components that are affected by wear needs to be verified during a type examination.</p> <p>Basis for the verification is the $B_{0,01d}$ value of the tested components which needs to be higher than the prescribed overhaul/lifetime by the manufacturer.</p> <p>The $B_{0,01d}$ value is based on the B_{10d} value used by EN ISO 13849-1:2015.</p> <p>The $B_{0,01d}$ value can be determined by calculation and verified by testing.</p>			

(1) Essential health and safety requirement

Note: According to point 6.6 of the Guide of the implementation of directives based on the New Approach and the Global Approach, the notified bodies apply as general guidance this recommendation for use.

	CO-ORDINATION OF NOTIFIED BODIES Machinery Directive 2006/42/EC + Amendment RECOMMENDATION FOR USE	CNB/M/11.027 Revision 08 Language: E
Date of first stage: 10/04/1997	To be approved by:	Approved on:
Origin: VG11 Safety components	<input checked="" type="checkbox"/> Vertical Group <input checked="" type="checkbox"/> Horizontal Committee To be endorsed by: <input checked="" type="checkbox"/> Machinery Working Group....	25/10/2010 14/12/2010 Endorsed on: 23/05/2011
Question related to: Directive 2006/42/EC Article: Annex: IV-21 ESR (1):	EN/prEN: EN 574:1996 Clause: 5.7.1. CEN TC concerned: TC 114	Other: Other clause:
Key words: two-hand control devices, synchronous actuation		
<p>Question:</p> <p>For type III two-hand control devices, EN 574 requires synchronous actuation of both buttons in order to prevent defeating. This means that both buttons have to be actuated within a defined time range not larger than 0.5 sec.</p> <p>EN 574 allows time ranges smaller than 0.5 sec, but if the time range is too short, the operator has to concentrate highly on the synchronous actuation of the two buttons. From ergonomic aspects, this is bad. What is the minimum value of the time range?</p>		
<p>Solution:</p> <p>The requirement given in the Machinery Directive, Annex I, 1.1.6. "Under the intended conditions of use, the discomfort, fatigue and physical and psychological stress faced by the operator must be reduced to the minimum possible, taking into account ergonomic principles..." has to be observed.</p> <p>The Technical Committee responsible for EN 574 will be asked to specify a minimum value for the time range. In the meantime, for ergonomic reasons, a minimum value of 0.25 sec should be used.</p>		

(1) Essential safety requirement

Note: According to point 6.6 of the Guide of the implementation of directives based on the New Approach and the Global Approach, the notified bodies apply as general guidance this recommendation for use.

	CO-ORDINATION OF NOTIFIED BODIES Machinery Directive 2006/42/EC + Amendment RECOMMENDATION FOR USE	CNB/M/11.031 Revision 09 Language: E
Date of first stage: 01/11/2001	To be approved by:	Approved on:
Origin: VG11 Safety components	<input checked="" type="checkbox"/> Vertical Group	25/10/2010
	<input checked="" type="checkbox"/> Horizontal Committee	14/12/2010
	To be endorsed by:	Endorsed on:
Question related to: Directive 2006/42/EC Article: Annex: IV-19 ESR (1):	<input checked="" type="checkbox"/> Machinery Working Group....	23/05/2011
	EN/prEN: EN 61496-1/A2/Ed. 2/ CDV:2010 Clause: 4.2.2.3. GENELEC TC concerned: TC 44X	Other: Other clause:
Key words: ESPE Type 2 with PLC as means of periodic test		
<p>Question:</p> <p>A Type 2 ESPE (Electro-Sensitive Protective Equipment) consists of an assembly of a sensing device, a controlling/monitoring device and one or more Output Signal Switching Device(s) (OSSDs), which shall perform a test to reveal a failure to danger at power-on of the ESPE before going to the ON-state and at each reset as a minimum.</p> <p>This assembly can be implemented in one device, they can also be separated in two devices. In the latter case the testing and monitoring functionality can be performed in a non-safety-related PLC by software while the ESPE safety function is processed independently of the non-safety-related PLC.</p> <p>For the sensing device in combination with the controlling/monitoring device and the OSSD(s) an EC type-examination certificate can be issued.</p> <p>Is it permissible to issue an EC type-examination certificate for a sensing device intended to be combined with any customary non-safety-related PLC as a safety component according to Annex IV, 19 (Type 2 ESPE)?</p>		
<p>Solution:</p> <p>Yes, the periodic tests of the safety function during operation may be implemented in a non-safety-related PLC, if the following requirements are met:</p> <ul style="list-style-type: none"> • the testing is dynamic i.e. both high and low states are checked during the testing; • the software is as a known module protected from manipulation by the end user; • the standard PLC meets the environmental requirements of EN 61496-1 for a Type 2 ESPE; and • the instructions describe in detail: <ul style="list-style-type: none"> - the different elements which constitute the ESPE; - how the sensing device has to be connected with the PLC; and - how the fixed software module has to be implemented in the user program <p>An EC type-examination shall be carried out on this safety component consisting of the sensing device with an OSSD(s), the fixed software module, and a designated PLC with a Secondary Switching Device (SSD).</p> <p>The owner of the certificate is considered as the manufacturer of the ESPE.</p> <p>Depending on the application, the periodic test may need to be performed more often than described in the first part of the question above to achieve a desired safety performance.</p>		

(1) Essential safety requirement

Note: According to point 6.6 of the Guide of the implementation of directives based on the New Approach and the Global Approach, the notified bodies apply as general guidance this recommendation for use.

	CO-ORDINATION OF NOTIFIED BODIES Machinery Directive 2006/42/EC + Amendment RECOMMENDATION FOR USE	CNB/M/11.032 Revision 05 Language: E
Date of first stage: 24/09/2002	To be approved by:	Approved on:
Origin: VG11 Safety components	<input checked="" type="checkbox"/> Vertical Group <input checked="" type="checkbox"/> Horizontal Committee To be endorsed by: <input checked="" type="checkbox"/> Machinery Working Group....	25/10/2010 03/03/2004 Endorsed on: 24/12/2004
Question related to: Directive 2006/42/EC Article: Annex: IV-19 ESR (1):	EN/prEN: EN 61496-1:2004 + A1:2008 Clause: 4.2.5, A 5.4, A 6.4, A 7.4 CENELEC TC concerned: TC 44X	Other: Other clause:
Key words: Arrangement of visual indicators		
<p>Question:</p> <p>EN 61496-1:2004+A1:2008 demands that ESPE (a) have visual indicators for the OSSD (b) status (red/green) and for the start/restart interlock status (yellow). There is no specification about the location where these visual indicators are to be arranged</p> <p>Where shall these visual indicators be arranged?</p> <p>Abbreviations:</p> <p>(a) ESPE: Electro-sensitive protective Equipment</p> <p>(b) OSSD: Output Switching Signal Device</p>		
<p>Solution:</p> <p>All visual indicators shall provide sufficient information for the machine operator.</p> <p>For this reason the visual indicators for start / restart condition, mute status and blanking shall be arranged in such a way that they are readily visible from any position of the operator during normal operation of the machine for which the ESPE (a) is intended as a safeguard. Indicators for the actuation of the sensing device and output status of the OSSDs (b) are intended for installation and maintenance and for that reason do not need to be visible from all positions by the operator.</p> <p>(a) ESPE: Electro-sensitive protective Equipment</p> <p>(b) OSSDs: Output Switching Signal Devices</p>		
Adaptation procedure: FORMAL ADAPTATION IN CONFORMITY WITH DIRECTIVE 2006/42/EC		

(1) Essential safety requirement

Note: According to point 6.6 of the Guide of the implementation of directives based on the New Approach and the Global Approach, the notified bodies apply as general guidance this recommendation for use.

	CO-ORDINATION OF NOTIFIED BODIES Machinery Directive 2006/42/EC + amendments RECOMMENDATION FOR USE		CNB/M/11.033 Revision: 09 Language: EN
Number of pages: 1	Date: 03.07.2023	To be approved by:	Approved on:
Origin: VG11 Safety components		<input checked="" type="checkbox"/> Vertical Group	22.05.2019
		<input checked="" type="checkbox"/> Horizontal Committee	16.12.2021
		To be endorsed by:	Endorsed on:
		<input checked="" type="checkbox"/> Machinery Expert Group	23.03.2023
Question related to: Directive 2006/42/EC	Article: -	EN/prEN: EN 574 and EN ISO 13851	Other: -
Annex: IV - 21	EHSR (1): 1.2.1.	Normative clause: -	Other clause: -
CEN TC concerned: -			
Key words: -			
Question: When shall a single fault be detected when using a type III C two-hand control according to EN 574:1996+A1:2008 and/or EN ISO 13851:2019?			
Solution: In a type III C two-hand control device, a single fault shall be detected and lead to a safe state as soon as possible, but latest when a change of state of the output signal is requested (e. g. by releasing one or both of the control actuating devices). Note: It is state of the art for this application that mechanical faults of push buttons are excluded when the push-buttons are in accordance with EN 60947-5-1.			

(1) Essential health and safety requirement

Note: According to point 6.6 of the Guide of the implementation of directives based on the New Approach and the Global Approach, the notified bodies apply as general guidance this recommendation for use.

	CO-ORDINATION OF NOTIFIED BODIES Machinery Directive 2006/42/EC + Amendment RECOMMENDATION FOR USE		CNB/M/11.035 Revision 08 Language: E
Date of first stage: 24/09/2002	To be approved by:		Approved on:
Origin: VG11 Safety components	<input checked="" type="checkbox"/> Vertical Group <input checked="" type="checkbox"/> Horizontal Committee		25/10/2010 14/12/2010
		To be endorsed by: <input checked="" type="checkbox"/> Machinery Working Group....	Endorsed on: 23/05/2011
Question related to: Directive 2006/42/EC Annex: IV-19	Article: ESR (1):	EN/prEN: EN 61496:2004 + A1:2008 Clause: A.7 CEN TC concerned:	Other: Other clause:
Key words: Indication of a muted ESPE, colour of the mute indicator(s) of an ESPE			
<p>Question:</p> <p>EN 61496-1, Annex A.7 (Muting) requires an indication of the muted state of an ESPE (Electro-Sensitive Protective Equipment), but does not specify a colour. What colour should be used?</p> <p>Note 1: In the old prEN 50100-1 (clause 4.2.4) the colour of the indication of the muted condition of the ESPE was required to be white. Table 2 of EN 61310-1 requires yellow for warnings, but yellow could conflict with the indication of the start or restart interlock. According to ANSI B11.19 an amber light is recommended to be used to indicate that the safeguard is muted or bypassed.</p>			
<p>Solution:</p> <p>Both colours yellow or white may be used if there is no conflict with other indicators e. g. interlock.</p> <p>Note 2: EN 61496-1:2004+A1:2008, 4.2.5 requires:</p> <p>When there are two or more indicators of the same colour the function of each indicator shall be unambiguously marked.</p>			

(1) Essential safety requirement

Note: According to point 6.6 of the Guide of the implementation of directives based on the New Approach and the Global Approach, the notified bodies apply as general guidance this recommendation for use.

	CO-ORDINATION OF NOTIFIED BODIES Machinery Directive 2006/42/EC + Amendment RECOMMENDATION FOR USE	CNB/M/11.036 Revision 07 Language: E
Date of first stage: 28/09/2004	To be approved by:	
Origin: VG11 Saftey components	<input checked="" type="checkbox"/> Vertical Group <input checked="" type="checkbox"/> Horizontal Committee	Approved on: 25/10/2010 14/12/2010
Question related to: Directive 2006/42/EC Article: Annex: IV-19 ESR (1):		EN/prEN: Other: Clause: Other clause: CEN TC concerned:
Key words: laser scanner, industrial truck		
Question: In narrow alleys of stocks persons may be injured by an industrial truck in case of collision between the industrial truck and a person. To prevent such accidents, laser scanners are used to detect persons and initiate a stop of the industrial truck. What are the conditions for laser scanners to be used in this application?		
Solution: Laser scanners (AOPDDRs) intended to be used for such applications shall fulfil the requirements of EN 61496-1 and CLC/TS 61496-3. As a minimum the additions and modifications listed below are to be observed. It is necessary to distinguish between those applications where: <ul style="list-style-type: none"> • access of persons is generally allowed; and • access of persons is forbidden at the time the industrial truck is operated. Therefore the following list contains general requirements and specific requirements for the two different applications (see annex).		

(1) Essential safety requirement

Note: According to point 6.6 of the Guide of the implementation of directives based on the New Approach and the Global Approach, the notified bodies apply as general guidance this recommendation for use.

1. General requirements

1.1 Detection zone dimensions

- The length of the detection zone shall be calculated taking into account the maximum speed of the industrial truck, the response times of the protective equipment, the machine control etc. and the maximum braking distance. An addition of 10 % as a minimum should be made to consider a decrease of the brakes.
- The width of the detection zone shall be such to enable the detection of the test piece defined in 1.2. It has to be taken into account that the tracking of an industrial truck always will have tolerances. For example, a tracking tolerance of 15 mm can lead to a change of the detection zones outer corner position in operation of some 10 mm. Without any user advice this can lead to problems concerning safety in terms of a decreased or not existing detection capability and on the other hand to an unacceptable low reliability in operation.

1.2 Test piece dimension

The test piece used for analysis and test shall be cylindrical with dimensions as indicated in figure 1. In most cases the detection capability will be affected by a test piece with minimum diffuse reflectivity.

Note: CLS/TS 61496-3 defines a minimum diffuse reflectivity of 1.8 % in the range of wavelength that is within the scope.

1.3 Detection capability

The detection of the test piece within the detection zone shall be guaranteed by test according to CLS/TS 61496-3. At the left and right outer border line of the detection zone the test piece shall be detected when placed with its centre in a distances of 125 mm from an empty rack. The maximum tracking tolerance as defined by the manufacturer of the protective device shall be taken into account.

1.4 Start interlock and restart interlock

Start interlock and restart interlock are required in operation when it is not guaranteed that a person is detected at any position in front of an industrial truck.

1.5 Accompanying documents

The accompanying documents shall inform the user on how to calculate the dimensions of the detection zone by example. The width of the detection zone is required to be given as a distance from the empty rack. The maximum tracking tolerance of the industrial truck together with other limiting information shall be given.

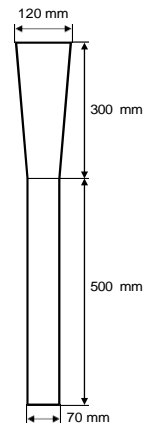

Figure 1: Test piece dimensions

2. Application where access is allowed

2.1 Type

Laser scanners intended to be used for this application shall fulfil the requirements for type 3 as defined in CLS/TS 61496-3.

2.2 Mounting

The mounting height of a laser scanner shall be as such as to enable the detection of the test piece defined in 1.2 and in addition of a person lying on the floor. To simulate this within a test, a second test piece with a diameter of 200 mm and a length of 1.000 mm shall be used.

3. Application where access is forbidden

3.1 Type

Laser scanners intended to be used for this application shall fulfil the requirements for type 3 as defined in CLS/TS 61496-3. Alternatively the fault detection requirements fulfilled by a type 2 device according to EN 61496-1 are sufficient due to the lower risk compared to the application where access is allowed.

3.2 Mounting

The mounting height of a laser scanner shall be such as to enable the detection of the test piece defined in 1.2.

3.3 Extra regulation

If the requirement to detect the test piece at the left and right outer border line of the detection zone given in 1.3 cannot be fulfilled taking into account the tracking tolerance of the industrial truck, the following extra regulation for application where access is forbidden can be applied.

- At the left and right outer border line of the detection zone the test piece shall be detected when placed with its centre in a distance of 125 mm from an empty rack. The tracking tolerance is not taken into account.
- The test piece position is varied from its original position (centre 125 mm from empty rack). For every 10 mm additional distance the length of the detection zone shall be increased by 200 mm.
- The maximum distance between the test piece centre and the empty rack is limited to 200 mm which leads to an increase of the detection zone of 1.500 mm.

	CO-ORDINATION OF NOTIFIED BODIES Machinery Directive 2006/42/EC + Amendment RECOMMENDATION FOR USE	CNB/M/11.047 Revision 03 Language: E
Date of first stage: 11/05/2010	To be approved by:	Approved on:
Origin: VG11 Safety components	<input checked="" type="checkbox"/> Vertical Group <input checked="" type="checkbox"/> Horizontal Committee	11/05/2010 15/06/2010
	To be endorsed by:	Endorsed on:
Question related to: Directive 2006/42/EC Article: Annex: I ESR (1): 1.2.1	EN/prEN: EN ISO 13849-1 / EN 62061 Clause: CEN TC concerned:	Other: Other clause:
Key words: Using parts with wear-out in safety components		
Question: How do parts with wear-out such as relays have to be taken into account when estimating the PFH _d (a) of a safety component? Abbreviation: (a) PFH _d : Probability of dangerous Failure per Hour		
Solution: The PL or SIL of a safety component depends on the PFH _d (a). It is not sufficient however to specify PFH _d (a) as the sole safety parameter without stating the conditions under which this value is valid. Standards such as EN ISO 13849-1 or EN 62061 use the concept of B10 _d when calculating probability of failures. This concept takes into account e.g. the average number of operations per time unit and the load conditions. Note: Information on procedures to determine B10 _d values are given e.g. in EN 60947-4-1 for contactors or in IEC 61810-2-1 for electromechanical elementary relays and ISO 19973-1, -2 for pneumatic components. Typical values for B10 _d can be found in EN ISO 13849-1, Annex C. VG11 replaced the term "PFH" by "PFH _d " and added the note on 26/10/2010.		

(1) Essential safety requirement

Note: According to point 6.6 of the Guide of the implementation of directives based on the New Approach and the Global Approach, the notified bodies apply as general guidance this recommendation for use.

	CO-ORDINATION OF NOTIFIED BODIES Machinery Directive 2006/42/EC + Amendment RECOMMENDATION FOR USE	CNB/M/11.049 Revision 03 Language: E
Date of first stage: 25/10/2010	To be approved by:	Approved on:
Origin: VG11 Safety components	<input checked="" type="checkbox"/> Vertical Group <input checked="" type="checkbox"/> Horizontal Committee	25/10/2010 14/12/2010
Question related to: Directive 2006/42/EC Article: Annex: IV-21 ESR (1):	EN/prEN: Clause: CEN TC concerned:	Other: Other clause:
Key words: logic units to ensure safety functions / Environmental conditions		
Question: Logic units to ensure safety functions shall be tested in environmental conditions (climatic, electrical, EMC, vibrations, bump, etc.). For the time being, there is no general standard for the detailed requirements. How can the test laboratory determine these requirements?		
Solution: There is no general standard for logic units and the requirements depend highly on the application, the technology used, and the expected environmental conditions. Therefore, it is the task of the Notified Body to determine the appropriate requirements.		

(1) Essential safety requirement

Note: According to point 6.6 of the Guide of the implementation of directives based on the New Approach and the Global Approach, the notified bodies apply as general guidance this recommendation for use.

	CO-ORDINATION OF NOTIFIED BODIES Machinery Directive 2006/42/EC + Amendment RECOMMENDATION FOR USE	CNB/M/11.050 Revision 05 Language: E
Date of first stage: 18/10/2011	To be approved by:	Approved on:
Origin: VG11 Safety components	<input checked="" type="checkbox"/> Vertical Group <input checked="" type="checkbox"/> Horizontal Committee	06/06/2013 26/06/2013
Question related to: Directive 2006/42/EC Article: Annex: IV – 19, 20, 21 and Annex I ESR (1): 1.2.1	EN/prEN: Clause: CEN TC concerned:	Other: Other clause:
Key words: Failure, electromechanical outputs		
Question: What are the minimum requirements concerning the frequency of tests for failure detection in a safety-related system with 2 channels with electromechanical outputs (relays or contactors)?		
Solution: A functional test (automatic or manual) to detect failures shall be performed within the following test intervals: a) at least every month for PL e with Category 3 or Category 4 (according to EN ISO 13849-1) or SIL 3 with HFT (hardware fault tolerance) = 1 (according to EN 62061); b) at least every 12 months for PL d with Category 3 (according to EN ISO 13849-1) or SIL 2 with HFT (hardware fault tolerance) = 1 (according to EN 62061). NOTE: It is recommended that the functional test is initiated by the control system of the machine. If this is not possible, then it is recommended that the control system of the machine reminds the user (e.g. by an appropriate indication at the control panel) to perform a functional test of the safety function. If this is also not possible, an appropriate requirement has to be contained in the instructions for use.		

(1) Essential safety requirement

Note: According to point 6.6 of the Guide of the implementation of directives based on the New Approach and the Global Approach, the notified bodies apply as general guidance this recommendation for use.

	CO-ORDINATION OF NOTIFIED BODIES Machinery Directive 2006/42/EC + Amendment RECOMMENDATION FOR USE	CNB/M/11.052 Revision 02 Language: E
Date of first stage: 18/10/2011	To be approved by:	Approved on:
Origin: VG11 Safety components	<input checked="" type="checkbox"/> Vertical Group	18.10.2011
	<input checked="" type="checkbox"/> Horizontal Committee	13/12/2011
Question related to: Directive 2006/42/EC Article: 2 (c) Annex: ESR (1):	To be endorsed by:	Endorsed on:
	<input checked="" type="checkbox"/> Machinery Working Group....	23/04/2012
	EN/prEN:	Other:
	Clause:	Other clause:
	CEN TC concerned:	
Key words: Safety components, safety functions		
Question: Some devices (e.g. an industrial remote control) incorporate non-safety related functions and one or more safety functions. Are such devices to be considered as safety components in the sense of the Machinery Directive?		
Solution: Yes. As soon as a device serves to fulfil a safety function, it is considered as safety component in the sense of the Machinery Directive, provided that the other conditions according to Article 2 (c) of the Machinery Directive are met. The safety-related part has to fulfil the essential requirements of the Machinery Directive. During conformity assessment, the non-safety-related parts also have to be considered to ensure that they have no negative influence on the safety-related part.		

(1) Essential safety requirement

Note: According to point 6.6 of the Guide of the implementation of directives based on the New Approach and the Global Approach, the notified bodies apply as general guidance this recommendation for use.

	CO-ORDINATION OF NOTIFIED BODIES Machinery Directive 2006/42/EC + Amendment RECOMMENDATION FOR USE		CNB/M/11.053 Revision 03 Language: E
Date of first stage: 10/05/2012	To be approved by:		Approved on:
Origin: VG11 Safety components	<input checked="" type="checkbox"/> Vertical Group <input checked="" type="checkbox"/> Horizontal Committee		10/05/2012 28/06/2012
	To be endorsed by:		Endorsed on:
Question related to: Directive 2006/42/EC Article: Annex: I ESR (1): 1.2.1	EN/prEN: EN ISO 13849-1:2008 Other: Clause: 5.2.2. Other clause: CEN TC concerned: TC 114		
Key words: Manual reset function			
<p>Question:</p> <p>For the manual reset function in logic units to ensure safety functions, EN ISO 13849-1, subclause 5.2.2, 6th indent, requires the change of the state of the reset button from pressed to released.</p> <p>In some logic units to ensure safety functions the manual reset function was designed to react to the change of the state of the reset button from released to pressed, as was required in EN 954-1, subclause 5.4. Do these logic units comply with the requirements of the Machinery directive?</p>			
<p>Solution:</p> <p>Yes.</p> <p>In this case, the technical file has to contain a statement that the product does not fully comply with the 6th indent of subclause 5.2.2 of EN ISO 13849-1.</p> <p>The manufacturer of the logic unit has to show that the manual reset function has an appropriate Performance Level.</p> <p>The same level of safety provided by the technical solution in the 6th indent of subclause 5.2.2 of EN ISO 13849-1 can be achieved by other technical solutions.</p>			

(1) Essential safety requirement

Note: According to point 6.6 of the Guide of the implementation of directives based on the New Approach and the Global Approach, the notified bodies apply as general guidance this recommendation for use.

	CO-ORDINATION OF NOTIFIED BODIES Machinery Directive 2006/42/EC + Amendment RECOMMENDATION FOR USE	CNB/M/11.055 Revision 04 Language: E
Date of first stage: 07/06/2013	To be approved by:	Approved on:
Origin: VG11 Safety components	<input checked="" type="checkbox"/> Vertical Group <input checked="" type="checkbox"/> Horizontal Committee	02/06/2014 17/06/2014
	To be endorsed by:	Endorsed on:
	<input checked="" type="checkbox"/> Machinery Working Group....	08/01/2015
Question related to: Directive 2006/42/EC	Article: 2 (c)	EN/prEN:
Annex: I	ESR (1): 1.5.1.	Other:
	Clause:	Other clause:
	CEN TC concerned:	
Key words: Cogeneration plants, combined heat and power plants (CHP), grid monitoring		
Question:		
Is the grid monitoring device of a cogeneration plant considered a safety component in the sense of Article 2 (c) of the Machinery Directive, if it is placed on the market independently?		
Solution:		
Yes.		
<p>If a local installation with cogeneration plant is disconnected from the electrical power grid, the cogeneration plant could still feed energy into the local installation. This situation is hazardous because some persons might think there is no electrical hazard due to the disconnection from the electrical power grid. In these cases, grid monitoring devices are used to</p>		
<ul style="list-style-type: none"> - disconnect the cogeneration plant from the local installation, and - in some cases - - shut down the generator and prevent start-up. 		
<p>Grid monitoring devices therefore serve to reduce a risk coming from cogeneration plants and are consequently considered a safety component in the sense of Article 2 (c) of the Machinery Directive and furthermore as a logic unit for safety functions in the sense of Annex IV, item 21.</p>		

(1) Essential safety requirement

Note: According to point 6.6 of the Guide of the implementation of directives based on the New Approach and the Global Approach, the notified bodies apply as general guidance this recommendation for use.

 <p>EUROPEAN CO-ORDINATION OF NOTIFIED BODIES MACHINERY</p>	<p>CO-ORDINATION OF NOTIFIED BODIES Machinery Directive 2006/42/EC + Amendment</p> <p>RECOMMENDATION FOR USE</p>	<p>CNB/M/11.056 Revision 03</p> <p>Language: E</p>
<p>Date of first stage: 07/06/2013</p>	<p>To be approved by:</p>	<p>Approved on:</p>
<p>Origin: VG11 Safety components</p>	<p><input checked="" type="checkbox"/> Vertical Group</p> <p><input checked="" type="checkbox"/> Horizontal Committee</p> <p>To be endorsed by:</p> <p><input checked="" type="checkbox"/> Machinery Working Group....</p>	<p>07/06/2013 26/06/2013</p> <p>Endorsed on: 22/11/2013</p>
<p>Question related to: Directive 2006/42/EC Article: Annex: I ESR (1): 1.2.1.</p>	<p>EN/prEN: EN 574:1996+A1:2008 Clause: 5.7 CEN TC concerned: TC 114</p>	<p>Other: Other clause:</p>
<p>Key words: Two-hand control devices, synchronous actuation, operating conditions</p>		
<p>Question:</p> <p>EN 574:1996+A1:2008 requires in its subclause 5.7 a synchronous actuation of both actuators in a period of time less than or equal to 0.5 s.</p> <p>Is it necessary that this maximum synchronisation time is observed also under variation of operating conditions such as the supply voltage?</p>		
<p>Solution:</p> <p>Yes. The maximum synchronisation time is a safety feature and shall therefore not be exceeded under the operating conditions stated by the manufacturer.</p> <p>NOTE: Generally, all safety functions have to work correctly under the operating conditions stated by the manufacturer and by standards.</p>		

(1) Essential safety requirement

Note: According to point 6.6 of the Guide of the implementation of directives based on the New Approach and the Global Approach, the notified bodies apply as general guidance this recommendation for use.

	CO-ORDINATION OF NOTIFIED BODIES Machinery Directive 2006/42/EC + Amendment RECOMMENDATION FOR USE	CNB/M/11.058 Revision 03 Language: E
Date of first stage: 07/06/2013	To be approved by:	Approved on:
Origin: VG11 Safety components	<input checked="" type="checkbox"/> Vertical Group	07/06/2013
	<input checked="" type="checkbox"/> Horizontal Committee	26/06/2013
Question related to: Directive 2006/42/EC Article: 2(c) Annex: ESR (1):	To be endorsed by:	Endorsed on:
	<input checked="" type="checkbox"/> Machinery Working Group....	22/11/2013
	EN/prEN: Other: Clause: Other clause: CEN TC concerned:	
Key words: Safety component, warning device		
Question: Is a warning device that requires the action of the operator to achieve a safe state considered a safety component in the sense of Article 2 (c) of the Machinery Directive?		
Solution: No. However, the device can be assessed according to functional safety standards used for safety components.		

(1) Essential safety requirement

Note: According to point 6.6 of the Guide of the implementation of directives based on the New Approach and the Global Approach, the notified bodies apply as general guidance this recommendation for use.

	CO-ORDINATION OF NOTIFIED BODIES Machinery Directive 2006/42/EC + Amendment RECOMMENDATION FOR USE	CNB/M/11.059 Revision 03 Language: E								
Date of first stage: 03/06/2014	To be approved by:									
Origin: VG11 Safety components	<input checked="" type="checkbox"/> Vertical Group <input checked="" type="checkbox"/> Horizontal Committee	Approved on: 03/06/2014 17/06/2014								
		To be endorsed by: <input checked="" type="checkbox"/> Machinery Working Group....								
Question related to: Directive 2006/42/EC Article: Annex: IV - 19 / 20 / 21 ESR (1):	EN/prEN: EN 61508 Clause: CEN TC concerned: CLC/TC 65X	Other: Other clause:								
Key words: Diagnostic functions, EN 61508:2010										
Question: How shall failures in diagnostic functions in single-channel structures (HFT = 0) be analysed and evaluated if EN 61508:2010 is used?										
Solution: Failures in diagnostic functions that can directly introduce a failure in the safety function / element safety function should be handled like failures in the safety function / element safety function itself. For diagnostic functions that cause a critical state related to the safety function / element safety function in a two or more fault scenario one of the following approaches shall be applied: <ol style="list-style-type: none"> The diagnostic functions are considered as separate functions and shall fulfill the requirements as shown in the table below. <table border="1" data-bbox="247 1384 778 1556"> <thead> <tr> <th>Safety function</th> <th>Diagnostic function</th> </tr> </thead> <tbody> <tr> <td>SIL 1</td> <td>Basic safety principles</td> </tr> <tr> <td>SIL 2</td> <td>SIL 1</td> </tr> <tr> <td>SIL 3</td> <td>SIL 2</td> </tr> </tbody> </table> A failure in a diagnostic function that increases the probability that the safety function does not operate correctly when required, shall be classified as dangerous failure according to IEC 61508-4:2010, clause 3.6.7. A failure in a diagnostic function that leads directly to the safe state shall be classified as safe failure according to IEC 61508-4:2010, clause 3.6.8. <p>Note: For diagnostic functions monitoring only other diagnostics functions, no safety requirements have to be applied.</p>			Safety function	Diagnostic function	SIL 1	Basic safety principles	SIL 2	SIL 1	SIL 3	SIL 2
Safety function	Diagnostic function									
SIL 1	Basic safety principles									
SIL 2	SIL 1									
SIL 3	SIL 2									

(1) Essential safety requirement

Note: According to point 6.6 of the Guide of the implementation of directives based on the New Approach and the Global Approach, the notified bodies apply as general guidance this recommendation for use.

	CO-ORDINATION OF NOTIFIED BODIES Machinery Directive 2006/42/EC + amendments RECOMMENDATION FOR USE		CNB/M/11.060 Revision: 06 Language: EN
Number of pages: 1 Origin: VG11 Safety components	Date: 03.07.2023	To be approved by: <input checked="" type="checkbox"/> Vertical Group <input checked="" type="checkbox"/> Horizontal Committee To be endorsed by: <input checked="" type="checkbox"/> Machinery Expert Group	Approved on: 22.05.2019 16.12.2021 Endorsed on: 23.03.2023
Question related to: Directive 2006/42/EC Annex: IV - 19 / 20 / 21	Article: - EHSR (1): 1.2.1.	EN/prEN: - Normative clause: - CEN TC concerned: -	Other: - Other clause: -
Key words: External DC power supply of safety component, PELV, abnormal voltage			
Question: What abnormal supply voltage of an external DC power supply has to be considered for a safety component intended to be supplied with PELV (protective extra low voltage)?			
Solution: For supply voltages up to 60 V DC, the safety component has to remain in a safe state. NOTE: EN 60204-1:2018 as well as EN 60204-1:2006, require that PELV does not exceed 60 V DC, even in case of a failure.			

(1) Essential health and safety requirement

Note: According to point 6.6 of the Guide of the implementation of directives based on the New Approach and the Global Approach, the notified bodies apply as general guidance this recommendation for use.

	CO-ORDINATION OF NOTIFIED BODIES Machinery Directive 2006/42/EC + Amendment RECOMMENDATION FOR USE	CNB/M/11.061 Revision 06 Language: E
Date of first stage: 03/06/2014	To be approved by:	Approved on:
Origin: VG11 Safety components	<input checked="" type="checkbox"/> Vertical Group <input checked="" type="checkbox"/> Horizontal Committee	02/06/2015 29/06/2016
	To be endorsed by:	Endorsed on:
	<input checked="" type="checkbox"/> Machinery Working Group....	31/01/2018
Question related to: Directive 2006/42/EC	Article:	EN/prEN:
Annex: IV - 21	ESR (1):	Other:
	Clause:	Other clause:
	CEN TC concerned:	
Key words: RFID-based protective devices		
<p>Question: Protective devices for indirect detection of the presence of persons, for example by the use of RFID (radio-frequency identification) technology, are considered to be a logic unit to ensure safety functions as described by CNB/M/11.045. In applications such as baling presses where material is transported via a conveyor belt into the press, such RFID-based protective devices have been used successfully as a protective measure in the past. However, no standard exists that deals with such systems. Are there general requirements or a general standard to take into account for an EC type-examination of a RFID-based protective device?</p>		
<p>Solution:</p> <p>Since RFID-based protective devices are used in the same environment as electro-sensitive protective equipment (ESPE), the standard that describes the general requirements and tests for ESPE (EN 61496-1) shall be applied also in case of a RFID-based protective device.</p> <p>In the process of an EC type-examination also technology specific aspects shall be covered. The most important task in this case is to verify that the integrity of the detection capability of a RFID-based protective device is maintained:</p> <ul style="list-style-type: none"> - independent of the orientation of the tag; - independent from coverage of the tag by the human body; - independent from coverage of the tag by process material such as plastics, composite material or metal foils; - in presence of several (different) tags; - when using more than one RFID-based protective device. <p>Organizational measures have to focus on periodically scheduled checks and that all personnel exposed to the relevant risks is equipped with transponder tags. These organizational measures have to be covered by the instructions for use.</p>		

(1) Essential safety requirement

Note: According to point 6.6 of the Guide of the implementation of directives based on the New Approach and the Global Approach, the notified bodies apply as general guidance this recommendation for use.

	CO-ORDINATION OF NOTIFIED BODIES Machinery Directive 2006/42/EC + Amendment RECOMMENDATION FOR USE	CNB/M/11.062 Revision 04 Language: E
Date of first stage: 09/06/2015	To be approved by:	Approved on:
Origin: VG11 Safety components	<input checked="" type="checkbox"/> Vertical Group	09/06/2015
	<input checked="" type="checkbox"/> Horizontal Committee	02/12/2015
Question related to: Directive 2006/42/EC Article: 2 c) Annex: IV - 19 ESR (1):	To be endorsed by:	Endorsed on:
	<input checked="" type="checkbox"/> Machinery Working Group....	23/09/2016
	EN/prEN: EN ISO 13856 series	Other:
Key words: pressure-sensitive protective device, sensor, control unit, OSSDs, definition	Clause:	Other clause:
Question: What is a pressure-sensitive mat (or edge or buffer)?	CEN TC concerned:	
	Solution: According to the definitions in the EN ISO 13856 series, a pressure-sensitive protective device consists of a sensor, a control unit and OSSDs (output signal switching devices). Therefore, a sensor alone (although commonly referred to as mat, edge or buffer) is not a safety component in the sense of the Machinery Directive. Example: According to EN ISO 13856-1, 3.1, the definition of pressure-sensitive mat reads: "Sensitive protective equipment (ISO 12100:2010, 3.28.5) comprising a sensor (3.3) or sensors, a control unit (3.5) and one or more one or more output signal switching devices (3.6) which detects a person standing on it or who steps onto it and where the effective sensing area (3.4) is deformed locally when the sensor(s) is actuated." So in the EN ISO 13856 series, the term "mat" (or "edge" or "buffer") is not used for the sensor, but for the combination of sensor, control unit and OSSDs.	

(1) Essential safety requirement

Note: According to point 6.6 of the Guide of the implementation of directives based on the New Approach and the Global Approach, the notified bodies apply as general guidance this recommendation for use.

	CO-ORDINATION OF NOTIFIED BODIES Machinery Directive 2006/42/EC + amendments RECOMMENDATION FOR USE		CNB/M/11.063 Revision: 02 Language: EN
Number of pages: 1 Origin: VG11 Safety components	Date: 31.07.2023	To be approved by: <input checked="" type="checkbox"/> Vertical Group <input checked="" type="checkbox"/> Horizontal Committee To be endorsed by: <input checked="" type="checkbox"/> Machinery Expert Group	Approved on: 02.06.2016 31.05.2023 Endorsed on: 12.04.2024
Question related to: Directive 2006/42/EC Annex: IV - 19 / 20 / 21	Article: - EHSR (1): -	EN/prEN: - Normative clause: - CEN TC concerned: -	Other: - Other clause: -
Key words: EC type-examination, laboratory			
Question: Is the Notified Body allowed to use external test facilities for EC type-examinations of Machinery Directive Annex IV No. 19 and 21 safety components?			
Solution: The following options can be accepted: <ol style="list-style-type: none"> 1. Laboratory accredited by a signatory to the ILAC accreditation system for the scope of testing: In this case the test results from this test laboratory can be accepted. 2. Independent laboratory without recognised accreditation: In this case the NB has to assess the test facility by an initial and by surveillance audits for the scope of testing to confirm, whether it follows the requirements of EN ISO/IEC 17025. 3. Use of manufacturers' test facilities is only to be accepted where the testing is supervised by the notified body staff. The test report is either issued under the notified body's authority or the manufacturers report clearly states the conditions under which the testing was carried out including the involvement of the notified body staff. 			

(1) Essential health and safety requirement

Note: According to point 6.6 of the Guide of the implementation of directives based on the New Approach and the Global Approach, the notified bodies apply as general guidance this recommendation for use.

	CO-ORDINATION OF NOTIFIED BODIES Machinery Directive 2006/42/EC + Amendment		CNB/M/11.065 Revision 03 Language: E
Date of first stage: 01/06/2017	To be approved by:		Approved on:
Origin: VG11 Safety components	<input checked="" type="checkbox"/> Vertical Group <input checked="" type="checkbox"/> Horizontal Committee		01/06/2017 07/06/2017
	To be endorsed by:		Endorsed on:
	<input checked="" type="checkbox"/> Machinery Working Group.		31/01/2018
Question related to: Directive 2006/42/EC	Article:	EN/prEN: EN 61496-2:2013	Other:
Annex: IV - 19	ESR (1):	Clause: 4.2.2.4	Other clause:
IEC TC concerned: TC 44 / MT 61496-2			
Key words: AOPD, type			
<p>Question: EN 61496-2:2013 does not define requirements for an AOPD Type 3. Nevertheless, such devices can be found on the market. Should these Type 3 devices fulfil the special requirements of Type 2 or for Type 4 as long as the standard does not give such information?</p> <p>Solution:</p> <p>As long as EN 61496-2 does not define a Type 3 AOPD such devices shall fulfil the requirements and its related test procedures of the following:</p> <ul style="list-style-type: none"> • EN 61496-1 Type 3; • EN 61496-2 general requirements; and • EN 61496-2 Type 4 requirements given in the following subclauses: <ul style="list-style-type: none"> - 4.1.2.2.2 (Sensing function); - 4.2.12 (Integrity of the AOPD detection capability); - 4.3.5 (Light interference); and - A.11.3 (Functional requirements for a type 4 AOPD), if applicable. <p>Note: Subclause numbers are related to EN 61496-2:2013</p>			

(1) Essential safety requirement

Note: According to point 6.6 of the Guide of the implementation of directives based on the New Approach and the Global Approach, the notified bodies apply as general guidance this recommendation for use.

	CO-ORDINATION OF NOTIFIED BODIES Machinery Directive 2006/42/EC + amendments RECOMMENDATION FOR USE		CNB/M/11.067 Revision: 03 Language: EN
Number of pages: 1 Origin: VG11 Safety Components	Date: 03.07.2023	To be approved by: <input checked="" type="checkbox"/> Vertical Group <input checked="" type="checkbox"/> Horizontal Committee To be endorsed by: <input checked="" type="checkbox"/> Machinery Expert Group ...	Approved on: 22.01.2021 16.12.2021 Endorsed on: 23.03.2023
Question related to: Directive 2006/42/EC Annex: IV – 19, 20 and 21	Article: 2 safety components and logic unit EHSR (1): -	EN/prEN: IEC 62061 and ISO 13849-1 Validation activities Normative clause: - CEN TC concerned: -	Other: - Other clause: -
Key words: Testing, witness testing, remote testing of safety components and logic unit Validation criteria in line with ANNEX II (of the Guide to application of the Machinery Directive 2006/42/EC Edition 2.2 – October 2019) §418 Table of safety components which are considered to be logic units.			
Question: What are the rules of Procedure covering validation and testing, remote testing or witnessing testing for logic unit / safety component manufacturer's and for mandatory EC type examination certification.			
Solution: For items covered by items 19, 20 and 21 of annex IV 2006/42/EC machinery directive, notified bodies are certifying the associated safety component and logic units by several means that are mainly validation by analysis, validation by simulation and validation by tests. Remote validation and remote testing activities are possible but they remain in all cases under the responsibility of the notified body to accept or not. The following list is not an exhaustive list Validation by analysis covers: <ul style="list-style-type: none"> • Definition of the safety function • Validation by analysis of the compliance of the safety component / logic unit to the criteria of harmonized standards, standards and other technical specifications (qualitative and quantitative requirements of the standards - e.g. SIL/SIL CL for IEC 62061, category, PL, MTTFD, ... of ISO 13849-1) and safety analysis methods e.g. FMECA, Markov, ... • Other mandatory requirements of the machinery directive (instructions, EC declaration of conformity, technical file, marking, ...) Validation by simulation Validation by tests covers: <ul style="list-style-type: none"> • Functional test of the product to verify the characteristics of the safety function (e.g. response time, ...) • Environmental tests (mechanical tests-vibrations and shocks, EMC tests, temperature tests, ...) • Fault tests injections. 			

(1) Essential health and safety requirement

Note: According to point 6.6 of the Guide of the implementation of directives based on the New Approach and the Global Approach, the notified bodies apply as general guidance this recommendation for use.

	CO-ORDINATION OF NOTIFIED BODIES Machinery Directive 2006/42/EC + amendments RECOMMENDATION FOR USE		CNB/M/11.068 Revision: 02 Language: EN
Number of pages: 1 Origin: VG11 Safety Components	Date: 03.07.2023	To be approved by: <input checked="" type="checkbox"/> Vertical Group <input checked="" type="checkbox"/> Horizontal Committee To be endorsed by: <input checked="" type="checkbox"/> Machinery Expert Group	Approved on: 22.01.2021 16.12.2021 Endorsed on: 23.03.2023
Question related to: Directive 2006/42/EC Annex: IV – 19	Article: - EHSR (1): -	EN/prEN: EN IEC 61496-3:2019 Normative clause: - CEN TC concerned: -	Other: - Other clause: -
Key words: AOPDDR, IP protection class			
Question: Should a Notified Body issue an EC type examination certificate for an AOPDDR (e.g. laser scanner) if the manufacturer describes that the AOPDDR enclosure is opened on delivery and therefore does not meet the IP 65 degree of protection specified in EN IEC 61496-3:2019, 4.3.4?			
Solution: No. EN IEC 61496-3:2019 does not set any requirements to evaluate pollution of internal optical components. This is justified by the assumption that the required IP protection class is not maintained only in short term in rare cases, such as the replacement of an optical window or a connector. Delivery of an AOPDDR with an open enclosure contradicts the objective to maintain the detection capability.			

(1) Essential health and safety requirement

Note: According to point 6.6 of the Guide of the implementation of directives based on the New Approach and the Global Approach, the notified bodies apply as general guidance this recommendation for use.

	CO-ORDINATION OF NOTIFIED BODIES Machinery Directive 2006/42/EC + amendments RECOMMENDATION FOR USE		CNB/M/11.069 Revision: 02 Language: EN
Number of pages: 1 Origin: VG11 Safety components	Date: 03.07.2023	To be approved by: <input checked="" type="checkbox"/> Vertical Group <input checked="" type="checkbox"/> Horizontal Committee To be endorsed by: <input checked="" type="checkbox"/> Machinery Expert Group	Approved on: 14.09.2021 16.12.2021 Endorsed on: 23.03.2023
Question related to: Directive 2006/42/EC Annex: -	Article: - EHSR (1): -	EN/prEN: EN 60204-1:2018 Normative clause: 9.1.1 CEN TC concerned: TC 44X	Other: - Other clause: -
Key words: Transformers			
<p>Question:</p> <p>Clause 9.1.1 in EN 60204-1:2018 contains following exception for the requirement for transformers:</p> <p style="padding-left: 40px;">Exception: Transformers or switch mode power supply units fitted with transformers are not mandatory for machines with a single motor starter and/or a maximum of two control devices (for example, interlock device, start/stop control station).</p> <p>In an elder version of this standard (EN 60204-1:1998) the sentence was clearer:</p> <p style="padding-left: 40px;">Transformers are not mandatory for machines with a single motor starter and a maximum of two control devices (e.g. interlock device, start/stop control station).</p> <p>The use of "and" means that both conditions (only one motor starter, maximum of two control devices) need to be met to apply the exception ("transformers are not mandatory").</p> <p>The meaning of "and/or" is, that complying with either the first or the second or both conditions is necessary to apply the exception. This was most likely not the intention of the rule-setter.</p>			
<p>Solution:</p> <p>A corrigendum to the standard seems appropriate and the respective TC will be informed. In order to close the time gap until the publication of a correction, this RfU is intended to contribute to clarification.</p> <p>The exception should read:</p> <p style="padding-left: 40px;">Exception: Transformers or switch mode power supply units fitted with transformers are not mandatory for machines with not more than one motor starter and a maximum of two control devices (for example, interlock device, start/stop control station).</p>			

(1) Essential health and safety requirement

Note: According to point 6.6 of the Guide of the implementation of directives based on the New Approach and the Global Approach, the notified bodies apply as general guidance this recommendation for use.

	CO-ORDINATION OF NOTIFIED BODIES Machinery Directive 2006/42/EC + amendments RECOMMENDATION FOR USE		CNB/M/11.071 Revision: 02 Language: EN
Number of pages: 2 Origin: VG11 Safety Components	Date: 31.07.2023	To be approved by: <input checked="" type="checkbox"/> Vertical Group <input checked="" type="checkbox"/> Horizontal Committee To be endorsed by: <input checked="" type="checkbox"/> Machinery Expert Group	Approved on: 04.05.2023 31.05.2023 Endorsed on: 12.04.2024
Question related to: Directive 2006/42/EC Annex: IV – 19, 20 and 21 Annex V	Article: - EHSR (1): -	EN/prEN: IEC 62061 and ISO 13849-1 Normative clause: - CEN TC concerned: TC44, TC199, TC22, TC 77 & TC65/SC65A	Other: - Other clause: -
Key words: Lack of Clarity for EMC Immunity Testing for Safety Components and integral Safety Functions. The guidance in IEC 61000-6-7 or IEC 62326-3-1 on the “test techniques does not fully explain how to ensure correct increased immunity testing of the Safety Component’s Safety Functions is to be carried out.			
Question: What are the requirements for EMC immunity testing of Safety Components and integral Safety Functions?			
Solution: For Safety devices that are used for machinery sector, the additional requirements for EMC immunity are met by: <ol style="list-style-type: none"> 1) Application of increased levels defined and test frequencies ranges in IEC 61000-6-7 or IEC 61326-3 -1; 2) A Test Method that ensures each Safety Function is correctly and fully tested for susceptibility during the application of the “interfering test signal” (see following picture) e.g. <ul style="list-style-type: none"> • Using (typically) 1% incremental steps of the frequency test range; • Pause (dwell) on the selected test frequency long enough to ensure correct operation of the safety function “on demand”. Let the safety function remain “activated” for at least a further 5 seconds or a time period that has to be justified by the manufacturer (time that could depend on technology and embedded safety measures for the realization of the safety function) and ensure that the safety function does not “deactivate” unintentionally; • Intentionally remove the safety function “demand” and ensure the safety Function resets correctly; • Increment the test frequency by a 1% step and repeat this test method as above until the end of the frequency range is reached and confirm that the applicable “Increased Immunity” Performance Criteria as detailed in the applicable standard has been met. Note: <ol style="list-style-type: none"> a) For “normal” EMC Immunity testing – typically a 1% step in frequency and a pause depending upon the duration of the operating mode under test is used and the “Performance Criteria” applied. This is normally a continuous process and the performance is monitored for any “out of spec” matters – NO SAFETY is involved; b) In order to CORRECTLY test a safety system – whilst the 1% step is acceptable – the PAUSE / DWELL TIME (on each frequency step) must be long enough to ensure the correct operation of the Safety Function and EACH Safety Function MUST be tested in this way; c) If the “normal” EMC Immunity testing technique (i.e. 1% step and pause ONLY – before the next step) is followed for Safety systems then it is very likely that dangerous susceptibilities will not be revealed and if each Safety Function is fully tested at each 1% step how can it be known that no susceptibilities exist? 			

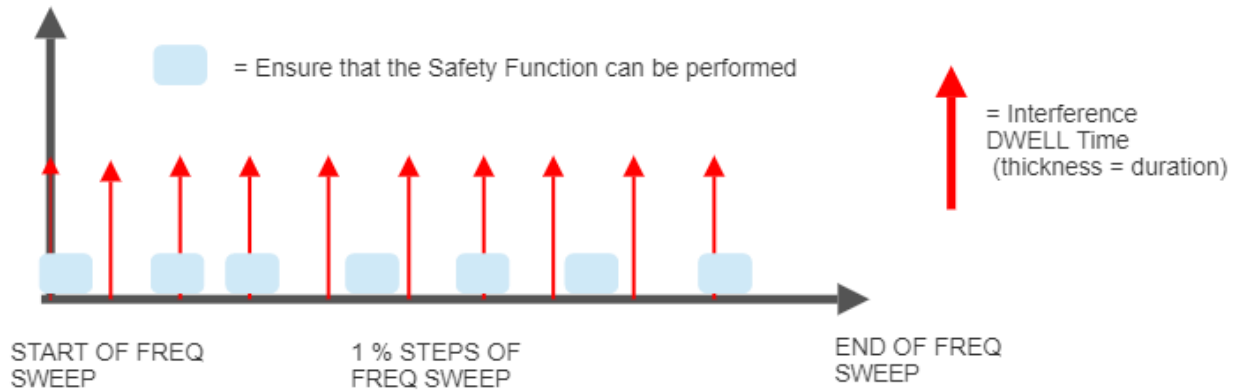

Continuous 1 % Sweep with INADEQUATE DWELL TIME AND REPEATED SAFETY FUNCTION TESTING (THAT DOES NOT RESULT IN CORRECT TEST OF SAFETY FUNCTION - SOME ARE ACTUALLY MISSED AND NOT TESTED)

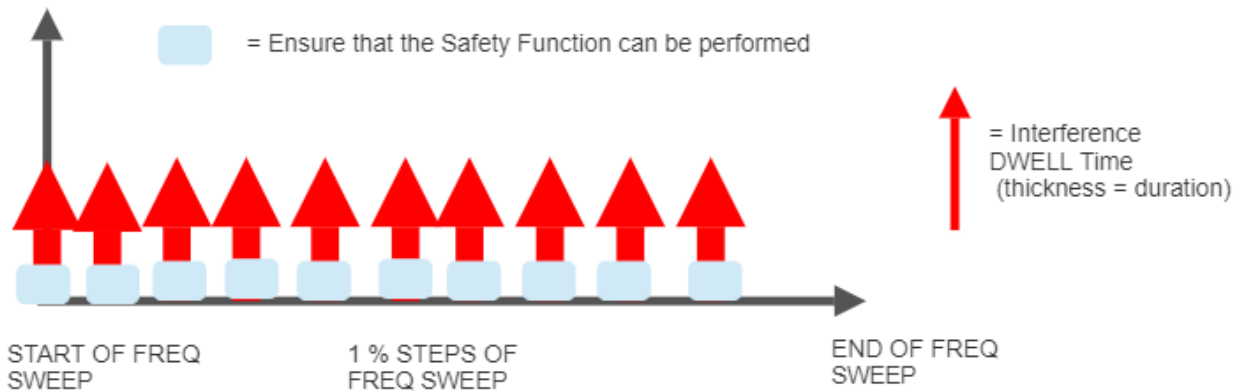

1 % Sweep with ADEQUATE DWELL TIME (THAT DOES RESULT IN CORRECT TEST OF SAFETY FUNCTION ALL 1% STEPS are TESTED)

(1) Essential health and safety requirement

Note: According to point 6.6 of the Guide of the implementation of directives based on the New Approach and the Global Approach, the notified bodies apply as general guidance this recommendation for use.

	CO-ORDINATION OF NOTIFIED BODIES Machinery Directive 2006/42/EC + Amendment RECOMMENDATION FOR USE	CNB/M/12.009 Revision 05 Language: E
Date of first stage: 07/05/1996	To be approved by:	
Origin: VG 12 ROPS and FOPS	<input checked="" type="checkbox"/> Vertical Group <input checked="" type="checkbox"/> Horizontal Committee	Approved on: 21/11/2013 10/12/2013
		To be endorsed by:
	<input checked="" type="checkbox"/> Machinery Working Group....	15/04/2014
Question related to: Directive 2006/42/EC Article: Annex: I ESR (1): 3.4.3., 3.4.4.	EN/prEN: Clause: CEN TC concerned:	Other: Other clause:
Key words: Minor modification		
Question: What kind of modifications of ROPS and FOPS can be accepted without new test?		
Solution: Safety cabs will be modified during the course of their production life. In order to make it simpler for all involved modifications to a tested safety cab may be made without requiring a retest. <ol style="list-style-type: none"> 1) Change of model denomination as a result of production processing, e.g. painting, trimming are not structural and therefore consideration to test mass used for a ROPS test may be the only additional information needed for model changes. 2) The drilling of holes for wiring or painting process and the addition for brackets for mounting of mirrors, lights, etc. needs consideration to given to the size an location and whether they would affect the test result. 3) Changes of seats resulting in new positions for SIP (seat index point), changes to the design or size of structural members including the addition of gussets, changes which affect the clearance between DLV (deflection-limiting volume) and safety cab or ground line changes of mounting brackets are beyond the understanding of minor modifications. This does not mean that they can not be considered. However as a notified body you must be confident that in the event of a fatal accident you can produce evidence that any modifications approved offer the same protection as the original design. It is also important to keep in mind that comparison tests between say different mounts is not the total affect on the original test, as the safety cab and mounts work as an unit. With these points in mind may we suggest that modifications of this nature are very hard to substantiate. <p>The additional data sheet of the original certificate must contain:</p> <ul style="list-style-type: none"> - a reference to the original certificate - a reference to the original test report - a unique number for this modifications - a description of the changes made including references to drawings and issue numbers - declaration of acceptance - the date of approval and – if applicable – limited series numbers 		

(1) Essential safety requirement

Note: According to point 6.6 of the Guide of the implementation of directives based on the New Approach and the Global Approach, the notified bodies apply as general guidance this recommendation for use.

	CO-ORDINATION OF NOTIFIED BODIES Machinery Directive 2006/42/EC + Amendment RECOMMENDATION FOR USE	CNB/M/12.010 Revision 05 Language: E
Date of first stage: 25/10/1996	To be approved by:	Approved on:
Origin: VG 12 ROPS and FOPS	<input checked="" type="checkbox"/> Vertical Group <input checked="" type="checkbox"/> Horizontal Committee	 21/11/2013 10/12/2013
	To be endorsed by:	Endorsed on:
Question related to: Directive 2006/42/EC Article: Annex: I ESR (1): 3.4.4.	EN/prEN: EN ISO 3449:2008 Clause: CEN TC concerned: TC 151 / ISO TC 27	Other: EN ISO 3411:2007 Other clause:
Key words: FOPS, Standing operator		
Question: What DLV (deflection-limiting volume) height shall be used for standing operator when testing FOPS according to EN ISO 3449?		
Solution: According to EN ISO 3411:2007 is the height of a large operator 1905 mm without helmet. The DLV height from the standing platform shall be 1955 mm (1905 mm + 50 mm for helmet).		

(1) Essential safety requirement

Note: According to point 6.6 of the Guide of the implementation of directives based on the New Approach and the Global Approach, the notified bodies apply as general guidance this recommendation for use.

	CO-ORDINATION OF NOTIFIED BODIES Machinery Directive 2006/42/EC + Amendment RECOMMENDATION FOR USE	CNB/M/12.012 Revision 07 Language: E	
Date of first stage: 27/10/2000	To be approved by:		
Origin: VG 12 ROPS and FOPS	<input checked="" type="checkbox"/> Vertical Group <input checked="" type="checkbox"/> Horizontal Committee	Approved on: 21/11/2013 10/12/2013	
	To be endorsed by: <input checked="" type="checkbox"/> Machinery Working Group....	Endorsed on: 15/04/2014	
Question related to: Directive 2006/42/EC	Article:	EN/prEN: EN ISO 3471:2008	Other:
Annex: I	ESR (1): 3.4.3.	Clause:	Other clause:
GEN TC concerned: TC 151 / ISO 127			
Key words: ROPS			
<p>Question:</p> <p>According to clause 6.1.4 of EN ISO 3471:2008 the load device shall not impede rotation of the ROPS. If two cylinders are used on a four-post ROPS, the test can be complete fail if the ROPS is allowed to rotate freely. How shall the the lateral and vertical load test be performed on test facilities with two loading cylinders?</p>			
<p>Solution:</p> <p>The requirement of clause 6.1.4 of EN ISO 3471:2008 is to be intended such that “load distribution device” does not constrain rotations of the structure. The use of one or two cylinders for loading is a matter of technical arrangement to fulfil the requirement laid down in clause 6.2.6 and 6.2.7 i.e. load application point displacement and force applied must be recorded in a “deformation controlled” loading sequence. ROPS structure rotation shall not be hindered but the loading device shall not induce rotation. The combination of the requirements suggest that in a two-cylinder loading machine, displacement of both cylinders must be controlled in order to meet the “deformation control” required by clause 6.2.6 and 6.2.7.</p> <p>The effective load application point resulting of the forces of the two cylinders shall always be within the boundary planes of the DLV (deflection-limiting volume).</p>			

(1) Essential safety requirement

Note: According to point 6.6 of the Guide of the implementation of directives based on the New Approach and the Global Approach, the notified bodies apply as general guidance this recommendation for use.

	CO-ORDINATION OF NOTIFIED BODIES Machinery Directive 2006/42/EC + Amendment RECOMMENDATION FOR USE		CNB/M/12.015 Revision 05 Language: E
Date of first stage: 18/08/2001	To be approved by:		Approved on:
Origin:	<input checked="" type="checkbox"/> Vertical Group <input checked="" type="checkbox"/> Horizontal Committee		21/11/2013 10/12/2013
		To be endorsed by:	Endorsed on:
Question related to: Directive 2006/42/EC Article:		EN/prEN:	Other:
Annex:	ESR (1):	Clause:	Other clause:
Key words: ROPS, FOPS, repair, substitution			
Question:			
Should a Notified Body take care of the fact that in case of an accident causing damage of a safety component (ROPS, FOPS) is can be necessary to replace the structure?			
Solution:			
<p>In principle no, because it is not a question related to the put into the market of the structure, however attention should be paid to the fact that mounting instructions or any other document clearly stresses the fact that repair after a damage is generally not allowed.</p> <p>The ROPS and FOPS structures are tested and certified to meet specific criteria, provided that the structures are identical to the one used in the test. In case of roll-over or in case of object impact, should any part of the structure be affected by plastic deformation or rupture, the aforementioned condition is not satisfied, and therefore the structure must be replaced, according to manufacturer's specification.</p>			

(1) Essential safety requirement

Note: According to point 6.6 of the Guide of the implementation of directives based on the New Approach and the Global Approach, the notified bodies apply as general guidance this recommendation for use.

	CO-ORDINATION OF NOTIFIED BODIES Machinery Directive 2006/42/EC + Amendment RECOMMENDATION FOR USE	CNB/M/12.016 Revision 02 Language: E
Date of first stage: 31/07/2013	To be approved by:	Approved on:
Origin: VG 12 ROPS and FOPS	<input checked="" type="checkbox"/> Vertical Group	21/11/2013
	<input checked="" type="checkbox"/> Horizontal Committee	10/12/2013
Question related to: Directive 2006/42/EC Article: Annex: I ESR (1): 3.4.4.	To be endorsed by:	Endorsed on:
	<input checked="" type="checkbox"/> Machinery Working Group....	15/04/2014
Key words: FOPS, tiltable cab	EN/prEN: EN ISO 3449:2008	Other: ISO 10262:2000
Question: How should the FOPS on a tiltable cab be tested?	Clause:	Other clause:
	CEN TC concerned: TC 151 / ISO 127	
Solution: For FOPS structures on tiltable cabs generally more than one test is necessary. At least one with the cab in horizontal position and one with the cab in the maximum tilted position. It has to be taken into account that the vertical projection of the DLV (deflection-limiting volume) changes when tilting the cab.		

(1) Essential safety requirement

Note: According to point 6.6 of the Guide of the implementation of directives based on the New Approach and the Global Approach, the notified bodies apply as general guidance this recommendation for use.

	CO-ORDINATION OF NOTIFIED BODIES Machinery Directive 2006/42/EC + Amendment RECOMMENDATION FOR USE		CNB/M/13.000 Revision 03 Language: EN
Date of first stage: 21/08/2008	To be approved by:		Approved on:
Origin: VG13 Full quality assurance	<input checked="" type="checkbox"/> Vertical Group..... <input checked="" type="checkbox"/> Horizontal Committee.....		21/08/2008 09/12/2008
		To be endorsed by:	Endorsed on:
		<input checked="" type="checkbox"/> Machinery Working Group..	18/06/2009
Question related to: 2006/42/EC	Article:	EN/prEN:	Other:
Annex: X	EHSR (1):	Normative clause:	Other clause:
		CEN TC concerned:	
Key words: equivalence to Annex IX			
Question: Do Annex IX and Annex X conformity assessment procedures lead to equivalent results, namely safe and compliant machines?			
Recommended solution: Yes. The outcome of Annex IX and Annex X conformity assessment procedures should be equivalent, namely safe and compliant machines. The focus of Annex IX is the type examination of a sample of the product by the Notified Body while for Annex X the focus of the Notified Body lies on the processes of design and manufacturing of the machinery. In both cases the manufacturer has responsibilities which can only be spot-checked by the Notified Body knowing that the outcome of both modules is considered equivalent.			

(1) Essential health and safety requirement

Note: According to point 6.6 of the Guide of the implementation of directives based on the New Approach and the Global Approach, the notified bodies apply as general guidance this recommendation for use.

	CO-ORDINATION OF NOTIFIED BODIES Machinery Directive 2006/42/EC + Amendment RECOMMENDATION FOR USE	CNB/M/13.002 Revision 07 Language: E
Date of first stage: 13/06/2009	To be approved by:	Approved on:
Origin: VG13 Full quality assurance	<input checked="" type="checkbox"/> Vertical Group	26/08/2010
	<input checked="" type="checkbox"/> Horizontal Committee	14/12/2010
Question related to: Directive 2006/42/EC Article: Annex: X clause 1 ESR (1):	EN/prEN:	Other:
	Clause:	Other clause:
	CEN TC concerned:	
Key words: quality system, compliance with standards, accreditation		
Question: Is it necessary for the manufacturer to have a quality system according to ISO 9001?		
Solution: No, compliance with the requirements of EN ISO 9001 normally provides a presumption of conformity to the relevant requirements of module H. However, since there are several additional requirements in the Annex X, compliance with ISO 9001 alone is certainly not sufficient as such to demonstrate compliance with the requirements of the directive. On the other hand, compliance with the standard is not mandatory, but the quality system must comply with the essential requirements of Annex X: no more, no less.		

(1) Essential safety requirement

Note: According to point 6.6 of the Guide of the implementation of directives based on the New Approach and the Global Approach, the notified bodies apply as general guidance this recommendation for use.

	CO-ORDINATION OF NOTIFIED BODIES Machinery Directive 2006/42/EC + Amendment RECOMMENDATION FOR USE		CNB/M/13.003 Revision 04 Language: E
Date of first stage: 21/01/2008	To be approved by:		Approved on:
Origin: VG13 Full quality assurance	<input checked="" type="checkbox"/> Vertical Group <input checked="" type="checkbox"/> Horizontal Committee To be endorsed by: <input checked="" type="checkbox"/> Machinery Working Group....		17/09/2007 10/06/2008 Endorsed on: 08/01/2009
Question related to: Directive 2006/42/EC Article: Annex: X clause 2.1 ESR (1):	EN/prEN: Clause: CEN TC concerned:		Other: Other clause:
Key words: application, quotation, selection of Notified Body			
Question: What is meant by application in the terms of clause 2.1 of Annex X and in particular the last bullet point?			
Solution: It is not the intention of this requirement to restrict the manufacturer from obtaining several quotations, but simply prevent the practice of going from one Notified Body (NB) to another until one will issue certification. It is permissible for the Manufacturer to approach one or more Notified Bodies (NBs) and invite them to issue a quotation for providing the necessary assessment services required by Annex X of the Machinery Directive 2006/42/EC. The NBs that have been approached may require the manufacturer to supply relevant information to enable them to prepare the required quotation. This information may be submitted verbally or in written form as required by the NB. Once the manufacturer has decided to select a single NB to provide the necessary services that manufacturer shall be required to enter into an agreement (e.g. a contract) with that NB. In that agreement the manufacturer declares that they have not entered into a contract with any other NB to provide similar services for the same category or categories of machine. The selected NB will then request (if not already provided) the remaining information specified within clause 2.1 of Annex X.			

(1) Essential safety requirement

Note: According to point 6.6 of the Guide of the implementation of directives based on the New Approach and the Global Approach, the notified bodies apply as general guidance this recommendation for use.

	CO-ORDINATION OF NOTIFIED BODIES Machinery Directive 2006/42/EC + Amendment RECOMMENDATION FOR USE	CNB/M/13.004 Revision 04 Language: E
Date of first stage: 21/01/2008	To be approved by:	Approved on:
Origin: VG13 Full quality assurance	<input checked="" type="checkbox"/> Vertical Group <input checked="" type="checkbox"/> Horizontal Committee To be endorsed by: <input checked="" type="checkbox"/> Machinery Working Group....	17/09/2007 10/06/2008 Endorsed on: 08/01/2009
Question related to: Directive 2006/42/EC Article: Annex: X clause 2.1 – 2 nd indent ESR (1):	EN/prEN: Clause: CEN TC concerned:	Other: Other clause:
Key words: manufacturer, sub-contractors, conformity, supplier, subsidiaries		
Question: Do substantial subcontract activities of the manufacturer need to be identified?		
Solution: Yes. Where the manufacturers sub-contract the whole, or a significant part, of either design, manufacturing, inspection, testing or installation (where installation is part of the deliverable) they shall declare this to the Notified Body they have selected to provide the services required. Significant in this context can mean an important activity which could have a bearing upon the final conformity of the product with the applicable legislation/standards (examples are full design of the machinery, manufacturing of an important subassembly having direct impact on safety). This does not apply to safety components (e.g. light curtains) or basic sub-assemblies procured completely from a supplier. The machinery manufacturer is responsible for obtaining from his sub-contractor the information and documentation required for the application of the Annex X. If the manufacturer is not able to provide the required documentation this shall be considered to be a major nonconformity. For important subcontracting the Notified Body shall be required to visit the sub-contractor site. This shall be made by the Notified Body or on behalf of the Notified Body. It is the responsibility of the machinery manufacturer to ensure access. The basic principle is that the same logic shall be applied to a virtual manufacturer and a real manufacturer. If relevant work has been performed by different Notified Bodies at the sub-contractor site, this should be taken into account.		

(1) Essential safety requirement

Note: According to point 6.6 of the Guide of the implementation of directives based on the New Approach and the Global Approach, the notified bodies apply as general guidance this recommendation for use.

	CO-ORDINATION OF NOTIFIED BODIES Machinery Directive 2006/42/EC + Amendment RECOMMENDATION FOR USE	CNB/M/13.005 Revision 04 Language: E
Date of first stage: 28/01/2008	To be approved by:	Approved on:
Origin: VG13 Full quality assurance	<input checked="" type="checkbox"/> Vertical Group <input checked="" type="checkbox"/> Horizontal Committee To be endorsed by: <input checked="" type="checkbox"/> Machinery Working Group....	17/09/2007 10/06/2008 Endorsed on: 08/01/2009
Question related to: Directive 2006/42/EC Article: Annex: X clause 2.1 – 3 rd indent ESR (1):	EN/prEN: Clause: CEN TC concerned:	Other: Other clause:
Key words: representative model, categories of machinery, risks		
Question: Who is choosing the model and what is the category?		
Solution: The headline of Annex IV is: “Categories of machinery to which one of the procedures referred to in Article 12(3) and (4) must be applied”. Categories are therefore defined, i.e. each group of machineries listed in one of the paragraphs from 1 to 23 or paragraphs 1.1, 1.2, 1.3, 1.4, 4.1, 4.2, 12.1, 12.2. Annex X clause 2.1 - 3 rd indent refers to “one model of each category”. This model is a representative sample that displays all the major hazards identified with the machinery. For purposes of conformity assessment to Annex X, the Notify Body shall select a model that represents the most complex machine in each category form the complete list of the products manufactured.		

(1) Essential safety requirement

Note: According to point 6.6 of the Guide of the implementation of directives based on the New Approach and the Global Approach, the notified bodies apply as general guidance this recommendation for use.

	CO-ORDINATION OF NOTIFIED BODIES Machinery Directive 2006/42/EC + Amendment RECOMMENDATION FOR USE	CNB/M/13.006 Revision 02 Language: E
Date of first stage: 08/10/2007	To be approved by:	Approved on:
Origin: VG13 Full quality assurance	<input checked="" type="checkbox"/> Vertical Group <input checked="" type="checkbox"/> Horizontal Committee To be endorsed by: <input checked="" type="checkbox"/> Machinery Working Group....	17/09/2007 04/12/2007 Endorsed on: 04/06/2008
Question related to: Directive 2006/42/EC Article: Annex: X clause 2.1 – 3 rd indent ESR (1):	EN/prEN: Clause: CEN TC concerned:	Other: Other clause:
Key words: EC declaration of conformity, technical file		
Question: Is it necessary to get a copy of the EC-declaration?		
Solution: Yes. A copy of the EC declaration of conformity is a component of the technical file. That is why the applicant should submit a draft of the EC declaration of conformity to the NB.		

(1) Essential safety requirement

Note: According to point 6.6 of the Guide of the implementation of directives based on the New Approach and the Global Approach, the notified bodies apply as general guidance this recommendation for use.

	CO-ORDINATION OF NOTIFIED BODIES Machinery Directive 2006/42/EC + Amendment RECOMMENDATION FOR USE		CNB/M/13.007 Revision 03 Language: E
Date of first stage: 28/01/2008	To be approved by:		Approved on:
Origin: VG13 Full quality assurance	<input checked="" type="checkbox"/> Vertical Group <input checked="" type="checkbox"/> Horizontal Committee		17/09/2007 04/12/2007
Question related to: Directive 2006/42/EC Article: Annex: X clause 2.1 - 3 rd indent ESR (1):		EN/prEN: Clause: CEN TC concerned:	Other: Other clause:
Key words: technical file, assessment on site, quality system			
Question: When does the technical file have to be made available to the NB?			
Solution: The technical file shall be made available to the NB before the assessment on site of the manufacturer is carried out. This is necessary, because the technical file will be used to validate the output of the quality system. The assessment of the quality system can only be positively finished if also the review of the technical file is positively finished. For this reason it is a recommendation for the machine manufacturer to submit the technical file as soon as possible. Note: When the NB has an experience on technical files related to specific categories of this manufacturer it may take it into account for the assessment of the technical files.			

(1) Essential safety requirement

Note: According to point 6.6 of the Guide of the implementation of directives based on the New Approach and the Global Approach, the notified bodies apply as general guidance this recommendation for use.

	CO-ORDINATION OF NOTIFIED BODIES Machinery Directive 2006/42/EC + Amendment RECOMMENDATION FOR USE		CNB/M/13.008 Revision 02 Language: E
Date of first stage: 08/10/2007	To be approved by:		Approved on:
Origin: VG13 Full quality assurance	<input checked="" type="checkbox"/> Vertical Group <input checked="" type="checkbox"/> Horizontal Committee To be endorsed by: <input checked="" type="checkbox"/> Machinery Working Group....		17/09/2007 04/12/2007 Endorsed on: 04/06/2008
Question related to: Directive 2006/42/EC Article: Annex: X clause 2.1 - 3 rd indent ESR (1):	EN/prEN: Clause: CEN TC concerned:		Other: Other clause:
Key words: complete technical file, documentation, complex machinery, audit			
Question: Does the complete technical file have to be made available?			
Solution: Yes. The complete technical file has to be made available to show that the quality system is capable of generating sufficient and complete documentation output according to the requirements of Annex VII, Part A. For complex machinery, it might be difficult to submit a very voluminous and complete technical file before the audit on site. The content of the documentation to be sent before the audit can be reduced in agreement with the NB. During the audit all the elements of the technical file must be available.			

(1) Essential safety requirement

Note: According to point 6.6 of the Guide of the implementation of directives based on the New Approach and the Global Approach, the notified bodies apply as general guidance this recommendation for use.

	CO-ORDINATION OF NOTIFIED BODIES Machinery Directive 2006/42/EC + Amendment RECOMMENDATION FOR USE		CNB/M/13.009 Revision 04 Language: E
Date of first stage: 28/01/2008	To be approved by:		Approved on:
Origin: VG13 Full quality assurance	<input checked="" type="checkbox"/> Vertical Group <input checked="" type="checkbox"/> Horizontal Committee To be endorsed by: <input checked="" type="checkbox"/> Machinery Working Group....		17/09/2007 10/06/2008 Endorsed on: 08/01/2009
Question related to: Directive 2006/42/EC	Article:	EN/prEN:	Other:
Annex: X clause 2.1 - 4 th indent	ESR (1):	Clause:	Other clause:
CEN TC concerned:			
Key words: quality system documentation, quality management manual, certificates, audit reports, language			
Question: Shall the complete documentation according to Annex X clause 2.2 of the quality system be submitted to the Notified Body prior to the audit?			
Solution: No, the applicant must make available a controlled copy of his quality management manual or any other type of documentation acceptable to the Notified Body (NB) in due time before the audit. This need not include all detailed processes but will focus on the procedures which were specifically developed in order to comply with the requirements of the directive. During the audit the complete documentation according to Annex X clause 2.2 must be checked. The language of the provided documentation must be acceptable to the NB. If the applicant requires the NB to take into account some elements already certified by another NB and or an accredited certification body, he shall provide the related certificates. Where appropriate the NB may require to review audit reports produced during the three last years.			

(1) Essential safety requirement

Note: According to point 6.6 of the Guide of the implementation of directives based on the New Approach and the Global Approach, the notified bodies apply as general guidance this recommendation for use.

	CO-ORDINATION OF NOTIFIED BODIES Machinery Directive 2006/42/EC + Amendment RECOMMENDATION FOR USE	CNB/M/13.010 Revision 04 Language: E
Date of first stage: 08/05/2008	To be approved by:	Approved on:
Origin: VG13 Full quality assurance	<input checked="" type="checkbox"/> Vertical Group <input checked="" type="checkbox"/> Horizontal Committee To be endorsed by: <input checked="" type="checkbox"/> Machinery Working Group....	17/09/2007 10/06/2008 Endorsed on: 08/01/2009
Question related to: Directive 2006/42/EC Article: Annex: X clause 2.2 - 3 rd indent ESR (1):	EN/prEN: Clause: CEN TC concerned:	Other: Other clause:
Key words: technical design specification, sample, manufacturing facilities, inspections, audit plan		
Question: What is the role of the Notified Body of reviewing the technical design specifications?		
Solution: During the assessment of the quality system, the Notified Body will at first verify that the harmonised standards used by the manufacturer are the correct ones with regard to the different categories of machinery presented by the manufacturer. Care will be taken about the fact that there might be necessary to use different standards to cover the various types of machinery within one category. The Notified Body will also pay attention to the procedures developed by the manufacturer in order to ensure that he uses the latest version of the relevant standard. If harmonised standards are not used, or are partially used the Notified Body will evaluate the adequacy of the principles developed in order to demonstrate compliance with the requirements of the directive (see also CNB/M/13.009). The control of the effectiveness of these principles is made by the assessment of the technical file.		

(1) Essential safety requirement

Note: According to point 6.6 of the Guide of the implementation of directives based on the New Approach and the Global Approach, the notified bodies apply as general guidance this recommendation for use.

	CO-ORDINATION OF NOTIFIED BODIES Machinery Directive 2006/42/EC + Amendment RECOMMENDATION FOR USE		CNB/M/13.011 Revision 04 Language: E
Date of first stage: 28/01/2008	To be approved by:		Approved on:
Origin: VG13 Full quality assurance	<input checked="" type="checkbox"/> Vertical Group <input checked="" type="checkbox"/> Horizontal Committee To be endorsed by: <input checked="" type="checkbox"/> Machinery Working Group....		17/09/2007 10/06/2008 Endorsed on: 08/01/2009
Question related to: Directive 2006/42/EC Article: Annex: X clause 2.2 - 2 nd indent ESR (1):	EN/prEN: Clause: CEN TC concerned:		Other: Other clause:
Key words: harmonized standards, responsibility, design review			
Question: What is the role of the Notified Body for the assessment of the technical design specifications that do not comply fully with harmonized standards?			
Solution: The Notified Body has to evaluate, whether the strategy for the selected means of the manufacturer is adequate to fulfil the requirements of the machinery directive. The manufacturer has to document the parts of a design which do not fully comply with harmonized standards and has to describe and justify (e.g. by risk assessment, use of approved practice, testing) the means that will be used to ensure that the essential health and safety requirements are fulfilled at least at an equivalent level of safety.			

(1) Essential safety requirement

Note: According to point 6.6 of the Guide of the implementation of directives based on the New Approach and the Global Approach, the notified bodies apply as general guidance this recommendation for use.

	CO-ORDINATION OF NOTIFIED BODIES Machinery Directive 2006/42/EC + Amendment RECOMMENDATION FOR USE	CNB/M/13.012 Revision 05 Language: E
Date of first stage: 28/01/2008	To be approved by:	Approved on:
Origin: VG13 Full quality assurance	<input checked="" type="checkbox"/> Vertical Group <input checked="" type="checkbox"/> Horizontal Committee To be endorsed by: <input checked="" type="checkbox"/> Machinery Working Group....	23/10/2012 (*) 10/06/2008 Endorsed on: 08/01/2009
Question related to: Directive 2006/42/EC Article: Annex: X clause 2.2 - 3 rd indent ESR (1):	EN/prEN: Clause: CEN TC concerned:	Other: Other clause:
Key words: design inspection, design verification, independence, level of confidence		
Question: Has the design inspection and design verification to be done by an independent person or department of the manufacturer?		
Solution: No, unless it is required by the quality system of the manufacturer or an applied standard. This directive, and others such as the PE-Directive and Lift Directive, and the current issue of the standard ISO 9001 do not explicitly require independence of persons or departments carrying out the design inspection and review. The manufacturer shall at least define responsibilities and competence for these persons and traceability of their actions. The manufacturer shall plan the inspection and review which shall be carried out under controlled conditions (instructions, checklists etc.). The final inspection shall include checking whether the design inspection and review has been performed correctly. Note: It is good practice to have design inspection and design verification performed by a person not directly involved in this design process. (*) Updating – to remove reference to an out of date version of ISO 9001		

(1) Essential safety requirement

Note: According to point 6.6 of the Guide of the implementation of directives based on the New Approach and the Global Approach, the notified bodies apply as general guidance this recommendation for use.

	CO-ORDINATION OF NOTIFIED BODIES Machinery Directive 2006/42/EC + Amendment RECOMMENDATION FOR USE		CNB/M/13.013 Revision 03 Language: E
Date of first stage: 28/01/2008	To be approved by:		Approved on:
Origin: VG13 Full quality assurance	<input checked="" type="checkbox"/> Vertical Group <input checked="" type="checkbox"/> Horizontal Committee To be endorsed by: <input checked="" type="checkbox"/> Machinery Working Group....		17/09/2007 04/12/2007 Endorsed on: 04/06/2008
Question related to: Directive 2006/42/EC Annex: X clause 2.2 - 3 rd indent and clause 2.3 - 1 st sentence	Article: ESR (1):	EN/prEN: Clause: CEN TC concerned:	Other: Other clause:
Key words: product complexity, validation, competence			
Question: How shall the NB consider the complexity of the product?			
Solution: The complexity of annex IV products may vary substantially. A circular saw with electro-mechanical control components only is for example less complex than a Logic Unit to ensure safety functions realized with several microprocessors (hardware and software) to control a work tool machine. The validation of the applied design process and the validation of the specific product need an adequate level of detail and therefore an adequate amount of time, which means that the conformity assessment process needs more time for complex products. At least one of the members of the audit team shall have appropriate competence in the technical field and in the corresponding ESHR of the MD.			

(1) Essential safety requirement

Note: According to point 6.6 of the Guide of the implementation of directives based on the New Approach and the Global Approach, the notified bodies apply as general guidance this recommendation for use.

	CO-ORDINATION OF NOTIFIED BODIES Machinery Directive 2006/42/EC + Amendment RECOMMENDATION FOR USE	CNB/M/13.014 Revision 04 Language: E
Date of first stage: 28/01/2008 Origin: VG13 Full quality assurance	To be approved by: <input checked="" type="checkbox"/> Vertical Group <input checked="" type="checkbox"/> Horizontal Committee To be endorsed by: <input checked="" type="checkbox"/> Machinery Working Group....	Approved on: 17/09/2007 10/06/2008 Endorsed on: 08/01/2009
Question related to: Directive 2006/42/EC Article: Annex: X clause 2.2 - 6 th indent; ESR (1): clause 2.3 - 1 st sentence	EN/prEN: Clause: CEN TC concerned:	Other: Other clause:
Key words: competency qualification of personnel, product specific requirements		
Question: How shall the Notified Body assess the qualifications of the manufacturer's personnel?		
Solution: The Notified Body shall ensure that records are available to demonstrate the competencies of personnel undertaking tasks which could affect the conformance of the product with the relevant legislation/standards. Competency shall include, but not be limited to, product knowledge, experience of particular processes and awareness of the applicable quality system procedures, the relevant standards and the directive.		

(1) Essential safety requirement

Note: According to point 6.6 of the Guide of the implementation of directives based on the New Approach and the Global Approach, the notified bodies apply as general guidance this recommendation for use.

	CO-ORDINATION OF NOTIFIED BODIES Machinery Directive 2006/42/EC + Amendment RECOMMENDATION FOR USE		CNB/M/13.015 Revision 04 Language: E
Date of first stage: 28/01/2008	To be approved by:		Approved on:
Origin: VG13 Full quality assurance	<input checked="" type="checkbox"/> Vertical Group <input checked="" type="checkbox"/> Horizontal Committee To be endorsed by: <input checked="" type="checkbox"/> Machinery Working Group....		17/09/2007 10/06/2008 Endorsed on: 08/01/2009
Question related to: Directive 2006/42/EC Annex: X clause 2.2 - 7 th indent; clause 2.3 - 1 st sentence	Article: ESR (1):	EN/prEN: Clause: CEN TC concerned:	Other: Other clause:
Key words: machinery design, quality, compliance			
Question: How shall the Notified Body assess the means of monitoring the achievement of the required design and quality of the machinery?			
Solution: There are two parts to this question: In the first instance, the Notified Body (NB) has to check demonstrated "design" compliance with the requirement of the machinery directive. This compliance is assessed by sampling, mainly by examination of the representative technical files as defined by Annex X of the directive. In addition to the ability of the manufacturer to prepare an adequate technical file, it is important to assess the procedures developed in order to ensure that the different versions of the machinery will still comply with the requirements, taking into account the evolution of the state of the art. In the second instance, the NB has to check the existence and application of procedures for effective control of the conformity of produced machinery to the "approved" design. These procedures must also ensure monitoring of subcontracted and/or licensed design and production. The manufacturer has to ensure that test or check result data are recorded and that annexed documents remain available for a period of ten years from the last date of manufacture of that product.			

(1) Essential safety requirement

Note: According to point 6.6 of the Guide of the implementation of directives based on the New Approach and the Global Approach, the notified bodies apply as general guidance this recommendation for use.

	CO-ORDINATION OF NOTIFIED BODIES Machinery Directive 2006/42/EC + Amendment RECOMMENDATION FOR USE	CNB/M/13.016 Revision 05 Language: E
Date of first stage: 2/01/2008	To be approved by:	Approved on:
Origin: VG13 Full quality assurance	<input checked="" type="checkbox"/> Vertical Group <input checked="" type="checkbox"/> Horizontal Committee To be endorsed by: <input checked="" type="checkbox"/> Machinery Working Group....	23/10/2012 (*) 10/06/2008 Endorsed on: 08/01/2009
Question related to: Directive 2006/42/EC Article: Annex: X clause 2.3 ESR (1):	EN/prEN: Clause: CEN TC concerned:	Other: Other clause:
Key words: existing certification, conformance, certified quality system		
Question: Can the NB fully rely on an existing certificate (e.g. for ISO 9001)?		
Solution: No. A quality system certified to ISO 9001 alone cannot be considered adequate to demonstrate conformance with the requirements of Annex X. An ISO 9001 certified quality system must be adapted to integrate the additional requirements of the Machinery Directive (in particular Annex X) , but it is up to the Notified Body (NB) undertaking the assessment to determine the extent to further modification. Only a NB can issue certification of conformance with Annex X of the Machinery Directive and such NBs must take full and sole responsibility for such certification. (*) Updating – to remove reference to an out of date version of ISO 9001		

(1) Essential safety requirement

Note: According to point 6.6 of the Guide of the implementation of directives based on the New Approach and the Global Approach, the notified bodies apply as general guidance this recommendation for use.

	CO-ORDINATION OF NOTIFIED BODIES Machinery Directive 2006/42/EC + Amendment RECOMMENDATION FOR USE	CNB/M/13.017 Revision 02 Language: E
Date of first stage: 08/10/2007	To be approved by:	Approved on:
Origin: VG13 Full quality assurance	<input checked="" type="checkbox"/> Vertical Group <input checked="" type="checkbox"/> Horizontal Committee To be endorsed by: <input checked="" type="checkbox"/> Machinery Working Group....	17/09/2007 04/12/2007 Endorsed on: 04/06/2008
Question related to: Directive 2006/42/EC Article: Annex: X clause 2.3 ESR (1):	EN/prEN: Clause: CEN TC concerned:	Other: Other clause:
Key words: auditors, experts, competence		
Question: Must the team of the auditors consist of at least two persons?		
Solution: No. The number of auditors shall be adequate for the size of the company or the number of the people involved and the complexity and number of categories of machinery. If the auditor's competence does not cover the scope, additional experts shall accompany the auditor(s). In this context the expert(s) shall not be regarded as an auditor.		

(1) Essential safety requirement

Note: According to point 6.6 of the Guide of the implementation of directives based on the New Approach and the Global Approach, the notified bodies apply as general guidance this recommendation for use.

	CO-ORDINATION OF NOTIFIED BODIES Machinery Directive 2006/42/EC + Amendment RECOMMENDATION FOR USE	CNB/M/13.018 Revision 02 Language: E
Date of first stage: 08/10/2007	To be approved by:	Approved on:
Origin: VG13 Full quality assurance	<input checked="" type="checkbox"/> Vertical Group <input checked="" type="checkbox"/> Horizontal Committee To be endorsed by: <input checked="" type="checkbox"/> Machinery Working Group....	17/09/2007 04/12/2007 Endorsed on: 04/06/2008
Question related to: Directive 2006/42/EC Article: Annex: X clause 2.3 ESR (1):	EN/prEN: Clause: CEN TC concerned:	Other: Other clause:
Key words: EHSR, technical file, review		
Question: How deep shall the review of the technical file be if its purpose is to ensure its compliance with the relevant HSR?		
Solution: Compliance with the essential health and safety requirements can only be ensured, if the technical file is reviewed in a similar manner to that required for module B, but without a detailed product inspection.		

(1) Essential safety requirement

Note: According to point 6.6 of the Guide of the implementation of directives based on the New Approach and the Global Approach, the notified bodies apply as general guidance this recommendation for use.

	CO-ORDINATION OF NOTIFIED BODIES Machinery Directive 2006/42/EC + Amendment RECOMMENDATION FOR USE		CNB/M/13.019 Revision 04 Language: E
Date of first stage: 28/01/2008	To be approved by:		Approved on:
Origin: VG13 Full quality assurance	<input checked="" type="checkbox"/> Vertical Group <input checked="" type="checkbox"/> Horizontal Committee To be endorsed by: <input checked="" type="checkbox"/> Machinery Working Group....		17/09/2007 10/06/2008 Endorsed on: 08/01/2009
Question related to: Directive 2006/42/EC Article: Annex: X clause 2.4 ESR (1):	EN/prEN: Clause: CEN TC concerned:		Other: Other clause:
Key words: product changes, changes of quality system, significant changes, contract			
Question: Is the planned change of the product covered by the planned change of the quality system?			
Solution: One of the tasks of a Notified Body (NB) in assessing and approving a full quality system is to review the technical file(s) for one model of each category of machinery referred to in Annex IV. A change of the quality system does not necessarily cause a change in the product nor - conversely - does a change of the machinery necessarily result in a change of the quality system. So the manufacturer shall only inform the NB about significant changes of the relevant technical files which may have implications on the quality system as well as direct changes of the quality system. It is recommended that contractual agreement between the NB and the manufacturer foresees the duty of the manufacturer to provide information on product changes and new products to the NB.			

(1) Essential safety requirement

Note: According to point 6.6 of the Guide of the implementation of directives based on the New Approach and the Global Approach, the notified bodies apply as general guidance this recommendation for use.

	CO-ORDINATION OF NOTIFIED BODIES Machinery Directive 2006/42/EC + Amendment RECOMMENDATION FOR USE		CNB/M/13.020 Revision 04 Language: E
Date of first stage: 28/01/2008	To be approved by:		Approved on:
Origin: VG13 Full quality assurance	<input checked="" type="checkbox"/> Vertical Group <input checked="" type="checkbox"/> Horizontal Committee To be endorsed by: <input checked="" type="checkbox"/> Machinery Working Group....		17/09/2007 10/06/2008 Endorsed on: 08/01/2009
Question related to: Directive 2006/42/EC Annex: X clause 2.3	Article: ESR (1):	EN/prEN: Clause: CEN TC concerned:	Other: Other clause:
Key words: notification, report, certificate			
Question: How should a Notified Body notify its decision?			
Solution: The Notified Body (NB) shall inform the Manufacturer or Authorised Representative of their assessment decision following the visit via a written report and/or an approval certificate. If this is not provided at the end of the assessment visit itself, the written report of findings and/or approval certificate should be submitted to the Manufacturer or Authorised Representative within a reasonable timeframe, normally within one month. Where approval certification is being withheld, the written report shall contain sufficient information and reasoned judgement to enable the Manufacturer or Authorised Representative to identify and take appropriate corrective action prior to requesting a further assessment visit. Whether issued via written report or an approval certificate, the NB shall ensure that certification is supported by a scope of approval, this will define exactly what has been approved in terms of products, manufacturing locations and any particular limitations.			

(1) Essential safety requirement

Note: According to point 6.6 of the Guide of the implementation of directives based on the New Approach and the Global Approach, the notified bodies apply as general guidance this recommendation for use.

	CO-ORDINATION OF NOTIFIED BODIES Machinery Directive 2006/42/EC + Amendment RECOMMENDATION FOR USE	CNB/M/13.021 Revision 04 Language: E
Date of first stage: 28/01/2008	To be approved by:	Approved on:
Origin: VG13 Full quality assurance	<input checked="" type="checkbox"/> Vertical Group <input checked="" type="checkbox"/> Horizontal Committee To be endorsed by: <input checked="" type="checkbox"/> Machinery Working Group....	17/09/2007 10/06/2008 Endorsed on: 08/01/2009
Question related to: Directive 2006/42/EC Article: Annex: X clause 3.3 ESR (1):	EN/prEN: Clause: CEN TC concerned:	Other: Other clause:
Key words: audit frequency and duration, surveillance audits		
Question: How often have surveillance audits to be done by Notified Bodies?		
Solution: The period between the audits should not be longer than 12 months. The duration and frequency of surveillance audits shall be determined by the Notified Body taking into account the complexity of the Manufacturer (e.g. number of sites, complexity of manufacturing processes, how much work is sub-contracted etc.), the products involved (e.g. the number and variety of individual products) and production volumes (e.g. higher volumes may require more frequent/longer visits). Also the former experience with this manufacturer may influence the duration and frequency of surveillance audits.		

(1) Essential safety requirement

Note: According to point 6.6 of the Guide of the implementation of directives based on the New Approach and the Global Approach, the notified bodies apply as general guidance this recommendation for use.

	CO-ORDINATION OF NOTIFIED BODIES Machinery Directive 2006/42/EC + Amendment RECOMMENDATION FOR USE		CNB/M/13.022 Revision 02 Language: E
Date of first stage: 08/10/2007	To be approved by:		Approved on:
Origin: VG13 Full quality assurance	<input checked="" type="checkbox"/> Vertical Group <input checked="" type="checkbox"/> Horizontal Committee To be endorsed by: <input checked="" type="checkbox"/> Machinery Working Group....		17/09/2007 04/12/2007 Endorsed on: 04/06/2008
Question related to: Directive 2006/42/EC Article: Annex: X clause 3.4 ESR (1):	EN/prEN: Clause: CEN TC concerned:		Other: Other clause:
Key words: unannounced visits, contracts			
Question: Are there additional conditions for unannounced visits?			
Solution: <p>Annex X of the directive indicates some of the reasons which might induce the need of unannounced visits. The frequency of these visits is a matter for the NB to determine at its discretion and, as appropriate following co-ordination with other notified bodies, but should not be unreasonable.</p> <p>A duly motivated complaint made to the NB by the Commission, a Member State, a manufacturer, another NB or any interested party is one of the factors which could trigger the need for an unexpected visit.</p> <p>It is recognised that the NB may carry out tests (or have them carried out) on the product where this is necessary to verify the quality system. Such tests should generally be confined to instances where clear evidence demonstrates that there is reasonable doubt about the effectiveness of the quality system to ensure that the machinery made under it conforms to the essential requirements of the directive.</p> <p>It is recommended that contractual agreement between the NB and the manufacturer foresees the possibility of these visits.</p>			

(1) Essential safety requirement

Note: According to point 6.6 of the Guide of the implementation of directives based on the New Approach and the Global Approach, the notified bodies apply as general guidance this recommendation for use.

	CO-ORDINATION OF NOTIFIED BODIES Machinery Directive 2006/42/EC + Amendment RECOMMENDATION FOR USE		CNB/M/13.023 Revision 04 Language: E
Date of first stage: 08/10/2007	To be approved by:		Approved on:
Origin: VG13 Full quality assurance	<input checked="" type="checkbox"/> Vertical Group <input checked="" type="checkbox"/> Horizontal Committee		12/05/2009 10/06/2009
	To be endorsed by: <input checked="" type="checkbox"/> Machinery Working Group....		Endorsed on: 25/12/2009
Question related to: Directive 2006/42/EC Article: Annex: X clause 4 ESR (1):	EN/prEN: Clause: CEN TC concerned:		Other: Other clause:
Key words: obligation to preserve			
Question: Does only the technical file referenced in 2.1 of Annex X need to be kept available for the national authorities, for a period of ten years?			
Solution: No. Conformity with Annex X does not remove the general duties of the manufacturer as defined in Annex VII A. clause 2 (all technical files should be made available to the authorities for at least 10 years).			

(1) Essential safety requirement

Note: According to point 6.6 of the Guide of the implementation of directives based on the New Approach and the Global Approach, the notified bodies apply as general guidance this recommendation for use.

	CO-ORDINATION OF NOTIFIED BODIES Machinery Directive 2006/42/EC + Amendment RECOMMENDATION FOR USE	CNB/M/13.024 Revision 04 Language: E
Date of first stage: 28/01/2008	To be approved by:	Approved on:
Origin: VG13 Full quality assurance	<input checked="" type="checkbox"/> Vertical Group	17/09/2007
	<input checked="" type="checkbox"/> Horizontal Committee	10/06/2008
Question related to: Directive 2006/42/EC Article: Annex: X clause 4 ESR (1):	To be endorsed by:	Endorsed on:
	<input checked="" type="checkbox"/> Machinery Working Group....	08/01/2009
	EN/prEN: Other: Clause: Other clause: CEN TC concerned:	
Key words: obligation to preserve, quality assurance system documentation		
Question: Shall the Notified Body check whether a manufacturer of the machine keeps each version of the quality assurance system documentation for at least 10 years?		
Solution: Yes, the Notified Body must check whether a machine manufacturer keeps all versions of his quality assurance system which has had an effect on any Annex IV product for at least ten years after the last of those products was manufactured.		

(1) Essential safety requirement

Note: According to point 6.6 of the Guide of the implementation of directives based on the New Approach and the Global Approach, the notified bodies apply as general guidance this recommendation for use.

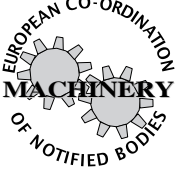
	CO-ORDINATION OF NOTIFIED BODIES Machinery Directive 2006/42/EC + Amendment RECOMMENDATION FOR USE		CNB/M/13.025 Revision 04 Language: E
Date of first stage: 28/01/2008	To be approved by:		Approved on:
Origin: VG13 Full quality assurance	<input checked="" type="checkbox"/> Vertical Group <input checked="" type="checkbox"/> Horizontal Committee To be endorsed by: <input checked="" type="checkbox"/> Machinery Working Group....		17/09/2007 10/06/2008 Endorsed on: 08/01/2009
Question related to: Directive 2006/42/EC Article: Annex: X clause 4 ESR (1):	EN/prEN: Clause: CEN TC concerned:		Other: Other clause:
Key words: last date of manufacture			
Question: What is meant by the last date of manufacture as used in Annex X?			
Solution: The last date of manufacture is the date upon which the last of a 'defined product' type is CE Marked with the intention of placing it on the market (be this into service or the supply chain). 'Defined product' means one that has a specific and unique identification name/number and is identified as such within a particular Technical File. The relevant records shall then be retained for a period of ten years from this last date of manufacture.			

(1) Essential safety requirement

Note: According to point 6.6 of the Guide of the implementation of directives based on the New Approach and the Global Approach, the notified bodies apply as general guidance this recommendation for use.

	CO-ORDINATION OF NOTIFIED BODIES Machinery Directive 2006/42/EC + Amendment RECOMMENDATION FOR USE		CNB/M/13.026 Revision 02 Language: E
Date of first stage: 08/10/2007	To be approved by:	Approved on:	
Origin: VG13 Full quality assurance	<input checked="" type="checkbox"/> Vertical Group	17/09/2007	
	<input checked="" type="checkbox"/> Horizontal Committee	04/12/2007	
Annex: X	To be endorsed by:	Endorsed on:	
	<input checked="" type="checkbox"/> Machinery Working Group....	04/06/2008	
Question related to: Directive 2006/42/EC	Article:	EN/prEN:	Other:
Annex: X	ESR (1):	Clause:	Other clause:
Key words: audit frequency and duration, assessment			
Question: Is there a minimum requirement for the time to be allocated to the assessment?			
Solution: The duration and frequency of assessment visits shall be determined by the NB taking into account the complexity of the Manufacturer (e.g. number of sites, complexity of manufacturing processes, how much work is sub-contracted etc.), the products involved (e.g. the number and variety of individual products) and production volumes (e.g. higher volumes may require more frequent/longer visits). Annex 2 of IAF Guide 62 should be used as a basis for determining a minimum baseline duration for the assessment visit (auditor time) to which additional time shall be added based upon experience gained from similar modules in other EC Directives.			

(1) Essential safety requirement

Note: According to point 6.6 of the Guide of the implementation of directives based on the New Approach and the Global Approach, the notified bodies apply as general guidance this recommendation for use.

	CO-ORDINATION OF NOTIFIED BODIES Machinery Directive 2006/42/EC + Amendment RECOMMENDATION FOR USE	CNB/M/13.029 Revision 03 Language: E
Date of first stage: 21/08/2008	To be approved by:	Approved on:
Origin: VG13 Full quality assurance	<input checked="" type="checkbox"/> Vertical Group <input checked="" type="checkbox"/> Horizontal Committee	21/08/2008 09/12/2008
Question related to: Directive 2006/42/EC Article: Annex: X ESR (1):	EN/prEN: Clause: CEN TC concerned:	Other: Other clause:
Key words: Subcontract		
Question: Is it possible for a Notified Body to subcontract to another Notified Body or another institution?		
Solution: Yes, it is permissible for a Notified Body to sub-contract some activities to another organisation including another NB or Subsidiary as defined within article R20 of the DECISION OF THE EUROPEAN PARLIAMENT AND OF THE COUNCIL ON A COMMON FRAMEWORK FOR THE MARKETING OF PRODUCTS 768/2008/CE: According to article 20, the original Notified Body must at least: <ul style="list-style-type: none"> ○ ensure that the subcontractor or the subsidiary meets the requirements set out for Notified Bodies and inform the notifying authority of their use; ○ take full responsibility for the tasks performed by subcontractors or subsidiaries wherever these are established; ○ have the agreement of the client; ○ ensure the other institution is technically competent; ○ clearly define the task(s) to be performed by the other institution and establish a suitable contract; and ○ monitor the performance of the subcontractor or subsidiary.. It should be noted that some Member States include within their terms of appointment a requirement for a Notified Body to advise them of all sub-contracted activities.		

(1) Essential safety requirement

Note: According to point 6.6 of the Guide of the implementation of directives based on the New Approach and the Global Approach, the notified bodies apply as general guidance this recommendation for use.

	CO-ORDINATION OF NOTIFIED BODIES Machinery Directive 2006/42/EC + Amendment RECOMMENDATION FOR USE		CNB/M/13.030 Revision 03 Language: E
Date of first stage: 21/08/2008	To be approved by:		Approved on:
Origin: VG13 Full quality assurance	<input checked="" type="checkbox"/> Vertical Group <input checked="" type="checkbox"/> Horizontal Committee		21/08/2008 09/12/2008
Question related to: Directive 2006/42/EC Article: Annex: X.3.3 ESR (1):		EN/prEN: Clause: CEN TC concerned:	Other: Other clause:
Key words: reassessment			
Question: How is re-assessment of the quality system achieved?			
Solution: The directive indicates that “the frequency of periodic audits shall be such that a full reassessment is carried out every three years”. This requirement gives two possibilities for reassessment: <ol style="list-style-type: none"> 1. The NB issues an approval certificate valid for a period of three years and embarks of a surveillance programme, including periodic audits, which ensure that all aspects of the quality system are assessed within the three years of validity. Prior to expiry of the approval certificate, the NB reviews the audits performed during that period and if this is considered satisfactory, it issues a new approval certificate valid for a further three years. or 2. The NB issues an approval certificate valid for a period of three years and embarks of a surveillance programme including periodic audits. Prior to expiry of the approval certificate the NB arranges to attend the manufacturers to perform a full reassessment of the quality system. If the assessment is found to be acceptable a new approval certificate, valid for a period of three years, is issued. <p>Note: Where the NB holds accreditation to EN ISO/IEC 17021, option 1 may not be permissible.</p>			

(1) Essential safety requirement

Note: According to point 6.6 of the Guide of the implementation of directives based on the New Approach and the Global Approach, the notified bodies apply as general guidance this recommendation for use.

	<p>CO-ORDINATION OF NOTIFIED BODIES Machinery Directive 2006/42/EC + Amendment</p> <p>RECOMMENDATION FOR USE</p>	<p>CNB/M/13.031 Revision 04</p> <p>Language: E</p>
<p>Date of first stage: 12/05/2009</p>	<p>To be approved by:</p> <p><input checked="" type="checkbox"/> Vertical Group</p> <p><input checked="" type="checkbox"/> Horizontal Committee</p> <p>To be endorsed by:</p> <p><input checked="" type="checkbox"/> Machinery Working Group....</p>	<p>Approved on:</p> <p>12/05/2009</p> <p>10/06/2009</p> <p>Endorsed on:</p> <p>25/12/2009</p>
<p>Origin: VG13 Full quality assurance</p>		<p>EN/prEN: _____ Other: _____</p> <p>Clause: _____ Other clause: _____</p> <p>CEN TC concerned:</p>
<p>Question related to: Directive 2006/42/EC Article:</p> <p>Annex: X ESR (1):</p>		
<p>Key words:</p>		
<p>Question:</p> <p>What are the duties of the Notified Body when a major non-compliance with Annex X or a major non-conformity of a product with Annex I is detected?</p> <p>Note: A major non-conformity is the absence of, or the failure to implement and maintain, one or more quality management system requirements, or a situation which would, on the basis of available objective evidence, raise significant doubt as to the conformity of what the manufacturer is supplying.</p>		
<p>Solution:</p> <p>The Notified Body suspends the approval of the quality system and requires the manufacturer to resolve the non-conformities within the shortest possible time. If these are not corrected appropriately, the Notified Body withdraws the approval of the quality system.</p> <p>Note: There are information obligations for the Notified Bodies according to Article 14.6 of Machinery Directive.</p>		

(1) Essential safety requirement
Note: According to point 6.6 of the Guide of the implementation of directives based on the New Approach and the Global Approach, the notified bodies apply as general guidance this recommendation for use.

	CO-ORDINATION OF NOTIFIED BODIES Machinery Directive 2006/42/EC + Amendment RECOMMENDATION FOR USE	CNB/M/13.034 Revision 04 Language: E
Date of first stage: 21/08/2008	To be approved by:	Approved on:
Origin: VG13 Full quality assurance	<input checked="" type="checkbox"/> Vertical Group	12/05/2009
	<input checked="" type="checkbox"/> Horizontal Committee	10/06/2009
Question related to: Directive 2006/42/EC Article: Annex: X ESR (1):	To be endorsed by:	Endorsed on:
	<input checked="" type="checkbox"/> Machinery Working Group....	25/12/2009
	EN/prEN:	Other:
	Clause:	Other clause:
Key words: certificate	CEN TC concerned:	
Question: What are the minimum contents of an Annex X approval certificate?		
Solution: A certificate of an Annex X approval of a quality assurance system shall contain as a minimum, the; <ul style="list-style-type: none"> ○ manufacturers name and address; ○ scope of approval, including category and/or sub-category of machines according to Annex IV and generic product description ○ limitations of the approval (if any); ○ date of issue; ○ date of expiry; ○ issuing Notified Body; and ○ person within the Notified Body authorising the certificate ○ names and addresses of the sites which have been assessed. <p>The above reflects the minimum information necessary, but is not an exhaustive list.</p> <p>An example certificate is attached to this RfU. The names and addresses of the sites assessed shall be listed in an annex to the certificate.</p>		

(1) Essential safety requirement

Note: According to point 6.6 of the Guide of the implementation of directives based on the New Approach and the Global Approach, the notified bodies apply as general guidance this recommendation for use.

Example Certificate

EC APPROVAL OF A QUALITY ASSURANCE SYSTEM

In accordance with the requirements of the
Machinery Directive 2006/42/EC

This is to certify that the Full Quality Assurance System of:

<Company Name>
<Company Address>
<Company Address>

has been assessed against the requirements of Annex X of Machinery Directive 2006/42/EC and conforms to the requirements for the following scope of approval:

Design and manufacture of <generic product description and any applicable limitations>

This certificate is only valid when accompanied by a current schedule with the same number detailing the categories of machinery corresponding to this approval.

Approval is subject to the continued surveillance of the Full Quality Assurance System in accordance with the requirements of the above Directive. Unauthorised changes to the Full Quality Assurance System will render this approval invalid.

Authorisation is hereby given to use the Notified Body Identification Number in accordance with the requirements of the specified Directive in relation to the categories of machinery identified in this certificate and accompanying schedule.

Certificate No: **<Certificate Number>**

Original Approval: **<Original Issue Date>**

Current Certificate: **<Subsequent Issue Date>**

Certificate Expiry: **<Expiry Date>**

Notified Body Number **<NB Number>**

Issued by: **<NB Signatory>**

	CO-ORDINATION OF NOTIFIED BODIES Machinery Directive 2006/42/EC + Amendment RECOMMENDATION FOR USE	CNB/M/13.037 Revision 03 Language: E
Date of first stage: 12/05/2009	To be approved by:	
Origin: VG13 Full quality assurance	<input checked="" type="checkbox"/> Vertical Group	Approved on: 12/05/2009
	<input checked="" type="checkbox"/> Horizontal Committee	10/06/2009
		To be endorsed by:
		<input checked="" type="checkbox"/> Machinery Working Group....
Question related to: Directive 2006/42/EC	Article:	EN/prEN:
Annex: X clause 3.2	ESR (1):	Other:
		Clause:
		Other clause:
		CEN TC concerned:
Key words: surveillance, quality system, technical file		
Question:		
According to Annex X, 2.1 the manufacturer has to lodge an application for assessment of this quality system containing the technical file for one model of each category of machinery he intends to manufacture. Is it acceptable if in the process of approval of the technical file there is no possibility to see the product during the assessment of the quality system by the Notified Body?		
Solution:		
No. At the very first audit the NB has to see at least one model of each category of machinery to assess the full quality assurance system. Where this model is different from the technical file that was audited a model of equivalent complexity has to be assessed at least once during each period of three years.		

(1) Essential safety requirement

Note: According to point 6.6 of the Guide of the implementation of directives based on the New Approach and the Global Approach, the notified bodies apply as general guidance this recommendation for use.

	CO-ORDINATION OF NOTIFIED BODIES Machinery Directive 2006/42/EC + Amendment RECOMMENDATION FOR USE	CNB/M/14.001 Revision 03 Language: E
---	---	--

Date of first stage: 17.10.2013	To be approved by:	Approved on:
Origin: VG 14 Portable cartridge-operated fixing and other impact machinery	<input checked="" type="checkbox"/> Vertical Group	11/12/2013
	<input checked="" type="checkbox"/> Horizontal Committee	18/06/2014
	To be endorsed by:	Endorsed on:
	<input checked="" type="checkbox"/> Machinery Working Group....	08/01/2015

Question related to: Directive 2006/42/EC Article: 2.2.2	EN/prEN: EN 15895	Other: EN16264
Annex: I and IV	ESR (1):	Other clause: ISO12100
	Clause: 6.5	
	CEN TC concerned: TC 213 WG 2	

Key words: Bolt setting devices, Cattle stunners, other hand held cartridge operated fixing and impact machinery

Question:
What kind of devices have to be treated under the Machine Directive Annex IV, No.18.

Solution:
Cartridge operated portable fixing and other impact machinery must be designed and constructed in such a way that energy is transmitted to the impacted element by the intermediary component that does not leave the device:

Classification of all known technical cartridge operated devices:

Cartridge Actuated Devices :	a) covered by Annex IV of MD	b) considered as fire arms not in scope of MD
Bolt Setting Device (indirect piston driven)	X	
Bolt Shooting Device (direct cartridge driven)		X
Hard Marking Devices	X	
Cattle Stunning Devices	X*	
Cord Launching Devices		X
Cable Shooting Devices		X
Industrially Used Cannons		X
Self-Shooting Vole Trapping Devices		X
Seismological Test Explosion Devices		X
Cutting and Separating with Counter Bearings	X	
Water Shooting Devices and Disruptors		X
Launcher for Retriever Dog Training		X



a) Indirect actuating principle according to M.D. b) direct actuating principle

*See Guide to Application of the Machinery Directive 2006/42/EC, Print Version: June 2010, 2. Edition, para. 280

(1) Essential safety requirement

Note: According to point 6.6 of the Guide of the implementation of directives based on the New Approach and the Global Approach, the notified bodies apply as general guidance this recommendation for use.